

# 油式交流滤波电容器 ( 250Vac~500Vac ) AC filter capacitors ( Oil-filled type, 250Vac~500Vac )

## ■ 外形图 Outline Drawing

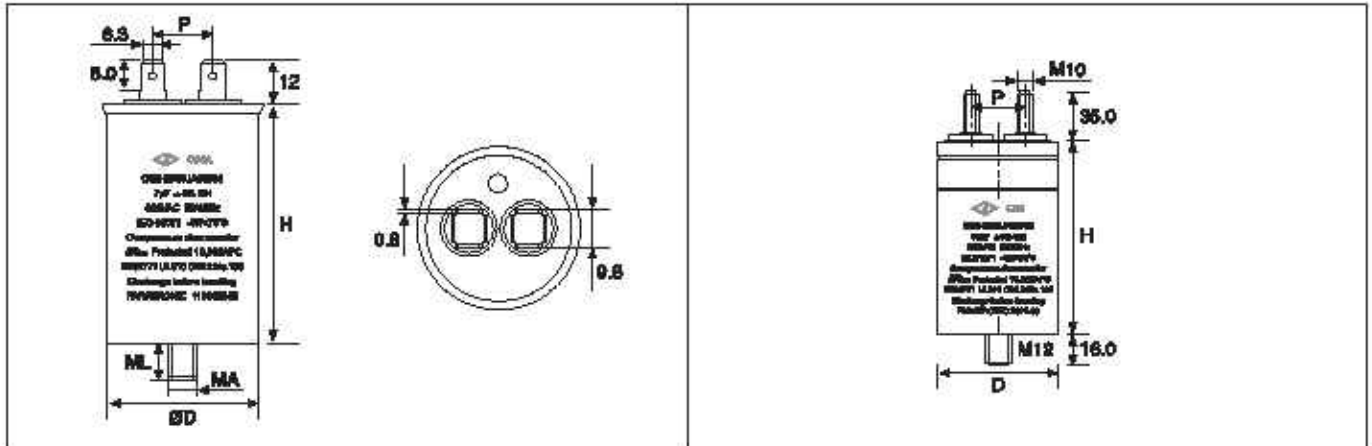

Type A(C66-A)

Type B(C66)

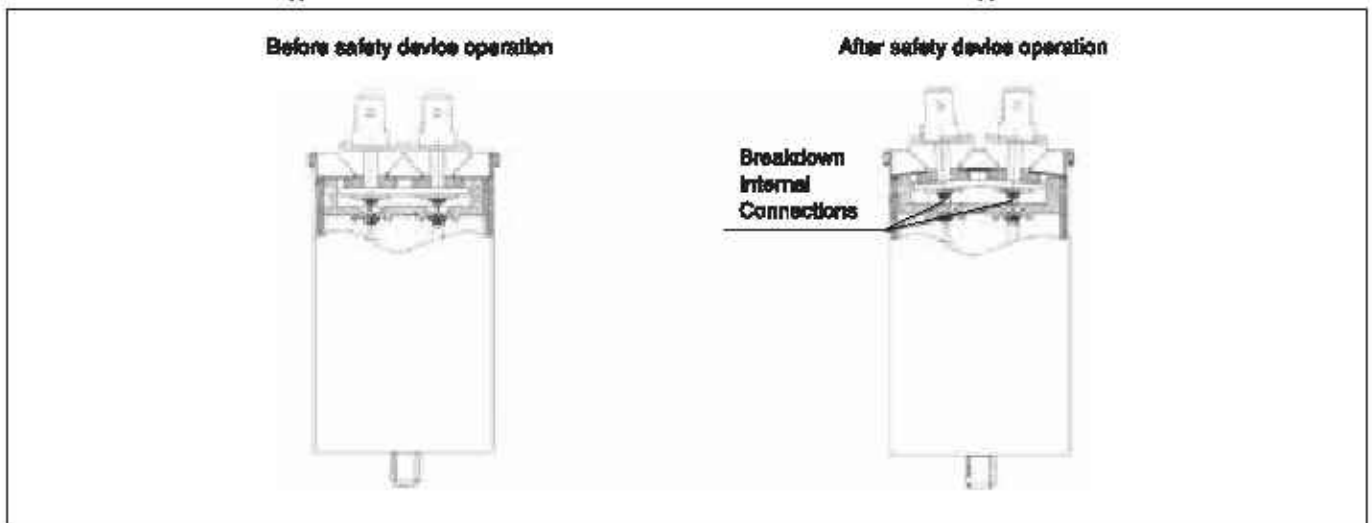

Before safety device operation

After safety device operation

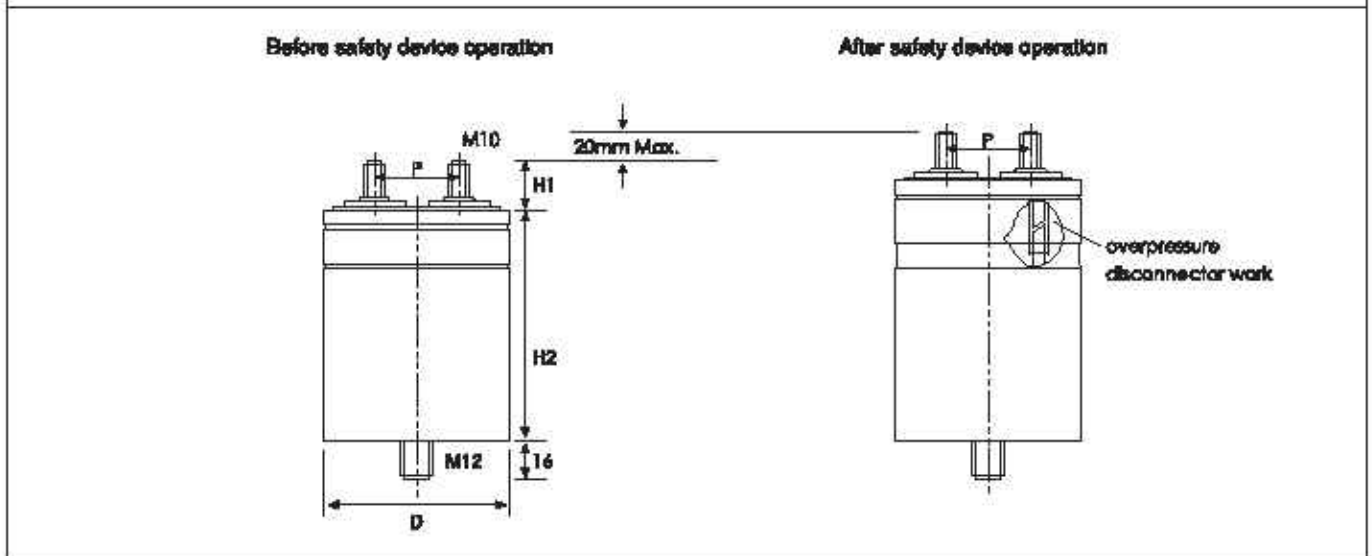

Before safety device operation

After safety device operation



C66

### ■ 特点

- 适用于电力电子设备、UPS电源中的交流滤波电路，能承受较高的谐波电流及峰值电流、电压
- 具有优良的自愈特性
- 高稳定性，可靠性
- 防爆设计，更安全

### ■ Features

- The capacitors particularly suit for AC filter circuit in power electric equipment and UPS power unit. They have ability to withstand high harmonic current, peak current and peak voltage
- Self-healing property
- Excellent stable performance and reliability
- Anti-explosion design, more safety

### ■ 安全认证 Safety Approvals

●		TUV Rheinland (德国)	EN 61071:2007, EN 61881-1:2011, U <sub>N</sub> : 350Vac~700Vac, U <sub>max</sub> : 250Vac~500Vac 3μF~600μF, -40℃/70℃ 证书号(Certificate No.): R 50269767
●		UL/CUL (美国/加拿大)	UL10, CSAC22.2.No190, Max. 540Vac, 50/60Hz, "Protected", 10 000AFC, Max.70℃ 证书号(Certificate No.): E232771, CCN: CYWT2/E

### ■ 技术要求 Specifications

引用标准 Reference standards	GB/T 17702 ( IEC 81071 )		
额定均方根电压 Rated RMS Voltage (U <sub>ma</sub> )	250Vac	350Vac	500Vac
额定电压 Rated a.c. Voltage (U <sub>N</sub> )	350Vac	480Vac	700Vac
额定频率 Rated frequency ( f <sub>N</sub> )	50/60Hz		
电容偏差值 Capacitance Tolerance	±5%, ±10%, -5% - +10%		
极间耐压 Test voltage between Terminals ( U <sub>T-T</sub> )	2.15U <sub>ma</sub> 或 1.5U <sub>N</sub> (50/60Hz), 10s		
极壳耐压 Test voltage between terminals to case ( U <sub>T-c</sub> )	3 000Vac(50/60Hz),10s		
绝缘电阻 Insulation Resistance ( IR × C <sub>M</sub> )	≥ 10 000s ( 20℃, 100V, 1min )		
介电损耗角正切 Dielectric dissipation factor ( tan δ <sub>d</sub> )	2 × 10 <sup>-4</sup> ( 50Hz, 20℃ )		
气候类别 Climatic category	40/70/56		
可运行温度范围(热点温度) Operating temperature range( θ <sub>ma</sub> )	-40℃ ~ 70℃		
存储温度范围 Storage Temperature	-40℃ ~ 70℃		
防护等级 Degree of protection	IP00		
预期寿命 Expected lifetime	ΔC/C   ≤ 5% after 80 000h @ U <sub>ma</sub> , θ <sub>ma</sub> ≤ 70℃		
安装位置 Mounting position	端子朝上 Terminals upright		
冷却方式 Cooling	自然空气或强制制冷 Naturally air-cooled or force cooled		
电极最大扭矩 Max Torque of terminals	8N·m ( TypeB )		
底部螺栓大小 Bottom bolts size	M8 × 10 ( D ≤ 50 )	M10 × 12 ( D=55 )	M12 × 16 ( D ≥ 80 )
最大安装扭矩 Max. Torque of Installation	6N·m	7N·m	10N·m
最高海拔 Max Altitude	2 000m		

## 产品编码说明 Part number system

### ■ 18位产品代码如下:

The 18 digits part number is formed as follow:

1	2	3	4	5	6	7	8	9	10	11	12	13	14	15	16	17	18
C	6	6															

第1-3位	型号代码	Digit 1 to 3	Series code
第4-5位	额定均方根电压 E2=250V R1=330V H2=500V	Digit 4 to 5	Rated RMS Voltage E2=250V R1=330V H2=500V
第6-8位	标称容量 举例: 506=50 × 10 <sup>6</sup> pF=50μF	Digit 6 to 8	Rated capacitance value For example: 506=50 × 10 <sup>6</sup> pF=50μF
第9位	容量等级 J=±5%,K=±10%,G=-5%~+10%	Digit 9	Capacitance tolerance J=±5%,K=±10%,G=-5%~+10%
第10位	产品外形尺寸代码	Digit 10	Dimension code

Code	D	H	外形样式 Style for dimension	Code	D	H	外形样式 Style for dimension
A	40	65	Type A	P	78	130	Type B
B	40	75	Type A	Q	76	145	Type B
C	48	75	Type A	R	78	150	Type B
D	50	75	Type A	S	78	170	Type B
E	55	75	Type A	T	78	180	Type B
F	60	75	Type A	1	78	200	Type B
G	60	80	Type A	2	85	200	Type B
H	60	105	Type A	3	85	220	Type B
J	60	115	Type A	4	85	230	Type B
K	80	130	Type A	5	85	240	Type B
L	78	105	Type B	6	85	250	Type B
M	78	110	Type B	7	90	85	Type A
N	78	120	Type B	8	40	85	Type A

第11位	内部特征码	Digit 11	Internal use
第12-15位	引出端形式代码	Digit 12 to 15	Terminals code

第12位 Digit 12		第13位 Digit 13		第14位 Digit 14		第15位 Digit 15	
代码 Code	引出端方式 Terminal form	代码 Code	固定式 Fixed style	代码 Code	引线长度 Length of lead wire	代码 Code	是否有电阻 whether has Resistor
2	M10 stud	5	底部螺栓 M8 Bottom-bolt M8	0	标准形式 Standard form	0	无 No
3	AMP250#	6	底部螺栓 M10 Bottom-bolt M10				
		7	底部螺栓 M12 Bottom-bolt M12				

第16-18位	内部特征码	Digit 16 to 18	Internal use
---------	-------	----------------	--------------



C66

■ 技术参数 Technical data (mm)

U <sub>max</sub> = 250Vac U <sub>U</sub> = 350Vac												
C <sub>N</sub> (μF)	D ± 1.0 (mm)	H ± 3.0 (mm)	F ± 1.5 (mm)	R <sub>c</sub> (mΩ)	L <sub>s</sub> (nH)	R <sub>th</sub> (K/W)	I <sub>max</sub> (A)	I <sub>1</sub> (kA)	I <sub>2</sub> (kA)	M (kg)	Part number	
15	40	65	18	10.7	80	21.9	9	0.4	1.3	0.15	C66E2156-A08500+++	
20	40	76	18	11.8	100	18.7	10	0.4	1.2	0.17	C66E2208-B08500+++	
25	40	75	18	9.8	100	17.7	11	0.5	1.5	0.17	C66E2256-B08500+++	
30	40	76	18	8.9	100	17.0	12	0.6	1.8	0.17	C66E2308-B08500+++	
35	45	75	18	7.6	100	15.7	13	0.7	2.1	0.2	C66E2356-C08500+++	
40	50	76	18	8.9	100	14.8	14	0.8	2.4	0.2	C66E2408-D08500+++	
50	50	76	18	5.9	100	13.7	14	1.0	3.0	0.2	C66E2508-D08500+++	
60	55	76	20	5.2	100	12.8	16	1.2	3.6	0.3	C66E2608-E08500+++	
80	60	76	20	4.3	100	11.2	18	1.6	4.8	0.3	C66E2808-F08700+++	
100	60	90	20	4.7	120	10.0	18	1.5	4.8	0.4	C66E2107-G08700+++	
120	60	106	20	5.4	150	9.0	16	1.3	3.9	0.4	C66E2127-H08700+++	
140	60	115	20	5.7	170	8.2	19	1.3	3.8	0.4	C66E2147-J08700+++	
150	60	130	20	6.8	210	7.7	16	1.0	3.1	0.6	C66E2157-K08700+++	
180	60	130	20	6.5	210	7.5	18	1.1	3.3	0.5	C66E2167-K08700+++	
150	76	120	35	4.1	140	7.7	25	2.0	6.9	0.7	C66E2157-N02700+++	
180	76	120	35	4.0	140	7.5	25	2.1	6.3	0.7	C66E2187-N02700+++	
180	76	130	35	4.4	160	7.1	25	1.9	6.8	0.8	C66E2187-P02700+++	
200	76	130	35	4.0	180	6.8	27	2.1	6.4	0.8	C66E2207-P02700+++	
230	76	145	35	4.6	190	6.3	25	1.9	6.8	0.8	C66E2237-Q02700+++	
250	76	145	35	4.3	190	6.1	27	2.1	6.3	0.8	C66E2257-Q02700+++	
300	76	200	35	2.0	140	4.7	45	3.9	11.7	1.0	C66E2307-102700+++	
350	76	200	35	1.8	140	4.4	48	4.8	19.7	1.1	C66E2357-102700+++	
400	85	200	35	1.8	140	4.2	52	5.2	16.8	1.3	C66E2407-202700+++	
500	85	220	35	1.7	160	3.7	53	5.4	18.1	1.4	C66E2507-302700+++	
600	85	230	35	1.8	170	3.3	58	5.9	17.7	1.4	C66E2607-402700+++	

U <sub>max</sub> = 330Vac U <sub>U</sub> = 460Vac												
C <sub>N</sub> (μF)	D ± 1.0 (mm)	H ± 3.0 (mm)	F ± 1.5 (mm)	R <sub>c</sub> (mΩ)	L <sub>s</sub> (nH)	R <sub>th</sub> (K/W)	I <sub>max</sub> (A)	I <sub>1</sub> (kA)	I <sub>2</sub> (kA)	M (kg)	Part number	
15	40	65	18	6.8	80	19.5	10	0.5	1.6	0.19	C66R1156-A08500+++	
20	40	76	18	9.8	100	17.1	11	0.5	1.5	0.15	C66R1208-B08500+++	
25	45	76	18	8.2	100	15.6	12	0.6	1.9	0.18	C66R1256-C08500+++	
30	50	76	18	7.1	100	14.3	14	0.8	2.3	0.21	C66R1308-D08500+++	
35	50	75	18	6.4	100	13.7	14	0.9	2.6	0.21	C66R1356-D08500+++	
40	55	75	20	5.8	100	12.8	16	1.0	3.0	0.25	C66R1408-E08600+++	
50	60	76	20	5.0	100	11.8	16	1.3	3.8	0.29	C66R1508-F08700+++	
60	60	80	20	5.6	120	10.6	16	1.14	3.4	0.33	C66R1608-G08700+++	
80	60	106	20	6.2	150	9.1	18	1.07	3.2	0.4	C66R1808-H08700+++	
100	60	130	20	7.9	210	7.6	18	0.9	2.6	0.45	C66R1107-K08700+++	
100	76	120	35	4.7	150	7.8	23	1.8	4.8	0.7	C66R1107-N02700+++	

### ■ 技术参数 Technical data (mm)

U <sub>max</sub> = 330V <sub>ac</sub> U <sub>v</sub> = 480V <sub>ac</sub>											
C <sub>N</sub> (μF)	D ± 1.0 (mm)	H ± 3.0 (mm)	P ± 1.5 (mm)	R <sub>th</sub> (mΩ)	L <sub>s</sub> (nH)	R <sub>th</sub> (K/W)	I <sub>max</sub> (A)	I <sub>1</sub> (kA)	I <sub>2</sub> (kA)	M (kg)	Part number
120	76	120	35	4.2	140	7.3	24	1.8	5.8	0.7	C66R1127-N02700+++
140	76	145	35	5.7	190	6.6	22	1.4	4.3	0.8	C66R1147-Q02700+++
150	78	145	35	5.4	180	6.4	23	1.8	4.7	0.8	C66R1157-Q02700+++
160	76	145	35	5.1	190	6.3	24	1.7	5.0	0.8	C66R1167-Q02700+++
180	78	145	35	4.7	180	6.1	25	1.8	5.6	0.8	C66R1187-Q02700+++
200	76	200	35	1.9	150	4.7	50	3.2	9.7	1.1	C66R1207-102700+++
230	78	200	35	1.7	140	4.5	53	3.7	11.1	1.1	C66R1237-102700+++
250	85	200	35	1.6	140	4.5	54	4.0	12.1	1.3	C66R1257-202700+++
300	85	200	35	1.4	140	4.1	60	4.8	14.5	1.3	C66R1307-202700+++
350	85	220	35	1.5	180	3.7	81	4.6	13.9	1.4	C66R1357-302700+++
400	85	250	35	1.8	190	3.3	59	4.1	12.4	1.6	C66R1407-602700+++

U <sub>max</sub> = 550V <sub>ac</sub> U <sub>v</sub> = 700V <sub>ac</sub>											
C <sub>N</sub> (μF)	D ± 1.0 (mm)	H ± 3.0 (mm)	P ± 1.5 (mm)	R <sub>th</sub> (mΩ)	L <sub>s</sub> (nH)	R <sub>th</sub> (K/W)	I <sub>max</sub> (A)	I <sub>1</sub> (kA)	I <sub>2</sub> (kA)	M (kg)	Part number
15	50	75	18	8.2	100	14.6	12	0.5	1.5	0.22	C66H2158-D08500+++
20	55	75	20	7.3	100	13.1	14	0.7	2.1	0.26	C66H2208-E08600+++
25	60	75	20	8.2	100	11.9	15	0.9	2.6	0.30	C66H2258-F08700+++
30	60	80	20	7.1	120	10.8	15	0.8	2.3	0.34	C66H2308-G08700+++
35	60	90	20	8.3	120	10.2	16	0.9	2.7	0.35	C66H2358-G08700+++
40	60	105	20	8.0	150	9.4	15	0.7	2.2	0.4	C66H2408-H08700+++
50	76	120	35	3.7	140	7.8	24	1.1	3.3	0.7	C66H2508-N02700+++
60	76	120	35	3.3	140	7.4	26	1.3	3.9	0.7	C66H2608-N02700+++
70	76	145	35	4.2	180	6.7	24	1.0	3.0	0.8	C66H2708-Q02700+++
80	76	145	35	3.8	190	6.4	26	1.1	3.4	0.8	C66H2808-Q02700+++
90	76	145	35	3.6	180	6.1	27	1.3	3.8	0.8	C66H2908-Q02700+++
100	76	200	35	1.4	140	4.8	53	2.2	6.5	1.1	C66H2107-102700+++
133	85	200	35	1.2	140	4.2	60	2.8	8.8	1.3	C66H2A00-202700+++
150	85	200	35	1.1	140	4.0	63	3.3	9.8	1.3	C66H2157-202700+++
200	85	220	35	1.1	180	3.5	87	3.8	10.7	1.4	C66H2207-302700+++
250	85	250	35	1.2	190	3.0	69	3.5	10.6	1.6	C66H2257-602700+++

- 备注: 1. "-" 表示公差值。 "-" = capacitance tolerance code, J=±5%,K=±10%,B=±5%~+10%。  
 2. "+++" 表示内部特征码。 "+++" = internal use  
 3. "R<sub>th</sub>" 是自然冷却条件下, 电容器内部热点到环境的阻值。  
 "R<sub>th</sub>" = R<sub>th</sub> between hotspot and ambient on natural cooling condition.  
 4. I<sub>max</sub> 可应要求提供更高数值。 For I<sub>max</sub> higher values available on request



# C66

## ● 安装空间要求 Installation space requirements

电容要安装在阴凉、通风良好的位置，且其周围不能有热辐射的物体，如滤波电路电抗器、太阳直射。

The capacitor is to be installed at a cool and well-ventilated place, and must not be installed within the range of heat radiating objects, e.g. filter circuit reactors, direct sun radiation.

电容必须要垂直安装，且引出端子朝上。

The capacitor must be mounted vertically and the terminal is upward.

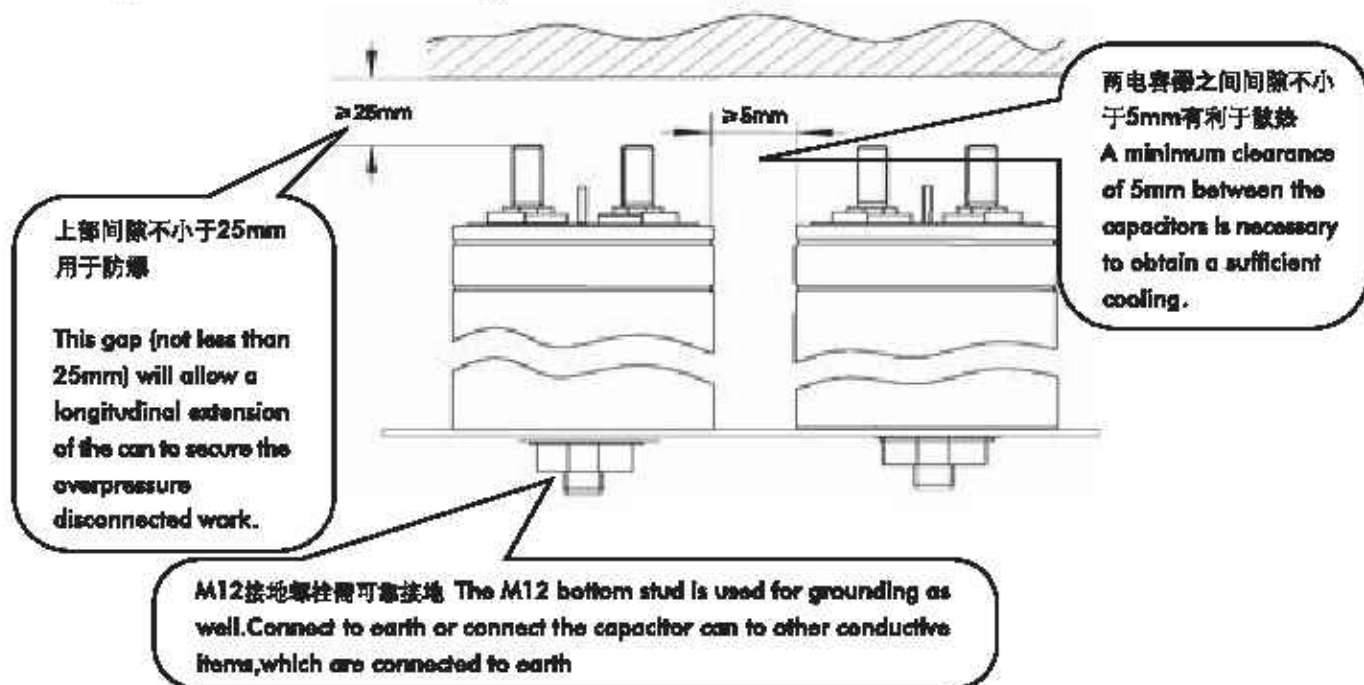

## ■ 端子安装连接电缆(以C6M型为例)

Install connecting cable to terminals (Take C6M type as an example)

对于多个电容器并联，每个电容器采用直接连接到母线上方式，若有其他连接方式请联系我们。

For capacitors connected in parallel, each capacitor should use independent lead wires, if you have any other connection way please contact us.

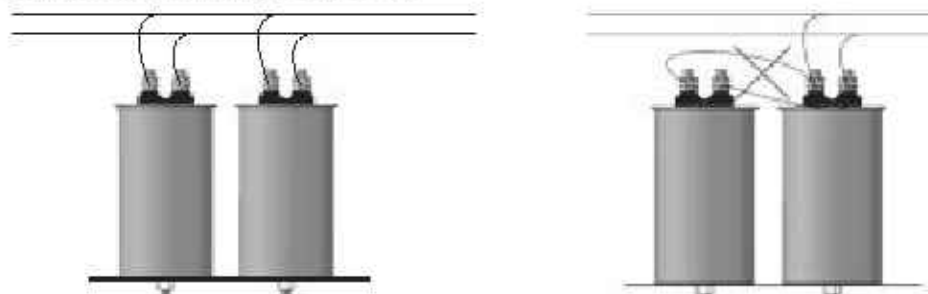

将电容使用三角形接法进行外部连接时，建议使用以下方式连接，避免汇流导致端子过热。

Capacitors using the delta connection in the external connection, it is recommended to use the following way connection, avoid terminals overheating due to current confluence.

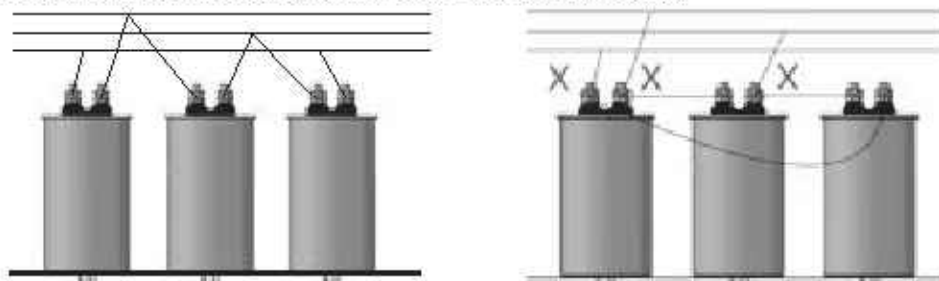



## ■ 连接电缆 Connection of the supply cable

上部必须保持足够的空间,该空间内不能安装其他组件。连接电缆应使用软性电缆并保持松弛,不要用硬芯电缆。

Keep enough space on the top of the capacitors and do not fix any mounting components at the top. The connection cable shall be of flexible type and keep slack, do not use hard core cable.

可根据实际电流值来选择合适的电缆 According to actual result to choose the appropriate cable.

## ■ 使用温度 temperature

温度对于聚丙烯膜式电容器来讲是影响损耗的一大因素,这会影响到产品的使用寿命。

Temperature is one of the main stress factors for polypropylene type capacitors, means it has a major influences on the life cycle of the capacitor.

## ■ 谐波 Harmonics

谐波是由于一些非线性电器运行时造成的,这些负荷诸如现代电力电子中的转换器、电气传动、焊接机、备用电源等。谐波由一系列频率为50Hz或60Hz倍数的正弦电流和电压组成。

Harmonics result from the operation of electrical loads with non-linear voltage-current characteristics.

They are caused by loads operated with modern power electronic, such as converters, electrical drives, welding machines and stand-by power supplies. Harmonics are sinusoidal voltages and currents with frequencies that are multiples of a 50Hz or 60Hz power supply frequency.

在使用过程中计算产品的温升以及核心热点温度是必要的,若使用过程中理论计算出的电容器热点超出了允许的最高范围,建议检查输入端的电流谐波畸变总数THD<sub>i</sub>,并联系我们的技术服务人员。

It is necessary to calculate the temperature rise of the capacitors from hotspot to case during the using process. If the temperature rise of theoretical calculation of capacitors' hotspot beyond the maximum allowable range, we would propose to check the total harmonic current distortion(THD<sub>i</sub>) of the input terminals, and contact our technical service personnel.

$$THD_i = \frac{\sqrt{\sum_{n=1}^{\infty} I_n^2}}{I_0} \quad (THD_i: \text{Total harmonic distortion, } I_0: \text{fundamental current, } I_n: \text{harmonic current})$$

## ■ 安全注意事项 Safety

电容器外壳保持良好和可靠接地。 Maintain good and effective earthing for enclosures of capacitors.

拆装电容器时要确保电容器已放电干净 Handle capacitor to ensure capacitor has discharge clean

遵循良好的工程规范 Follow good engineering practices

## ■ 过流/短路保护 Over current/short circuit protection

建议使用限流熔断器或塑壳断路器来进行短路保护。短路保护的元件以及连接电缆需能长时间承受1.5倍电容器额定电流。

HRC-fuse or MCCB for short circuit protection is recommended to use. Short circuit protection equipment and connection cable should be selected so that the 1.5 times rated current of the capacitor can be managed permanently.

限流熔断器额定电流值应为正常电容电流的1.6~1.8倍

HRC-fuse rating has to be 1.6 to 1.8 times nominal capacitor current

使用热磁继电器为过载保护

Use thermal magnetic overcurrent relays for overload protection

## ■ 维护 Maintenance

检查连接线与端子螺丝是否打紧

Check tightness of Connections/terminals periodically

定期清理引出端子避免因灰尘或其他可导电的垃圾引起短路

Clean the terminals periodically to avoid dust or other conductive garbage can cause a short-circuit

检查短路保护保险丝

Check short circuit protection fuses

每半年使用电流钳表或其他在线测电流的工具测量电容器电流

Every half a year use current clamp table or other on-line measuring tools of current measurement capacitor current