

Features

EDLC (Electric Double Layer Capacitor)

- High Power Density (Low ESR)
- Over 500,000 cycle life (semi-permanent)
- Short-term Peak Power assist applications
- RoHS compliant



Drawing

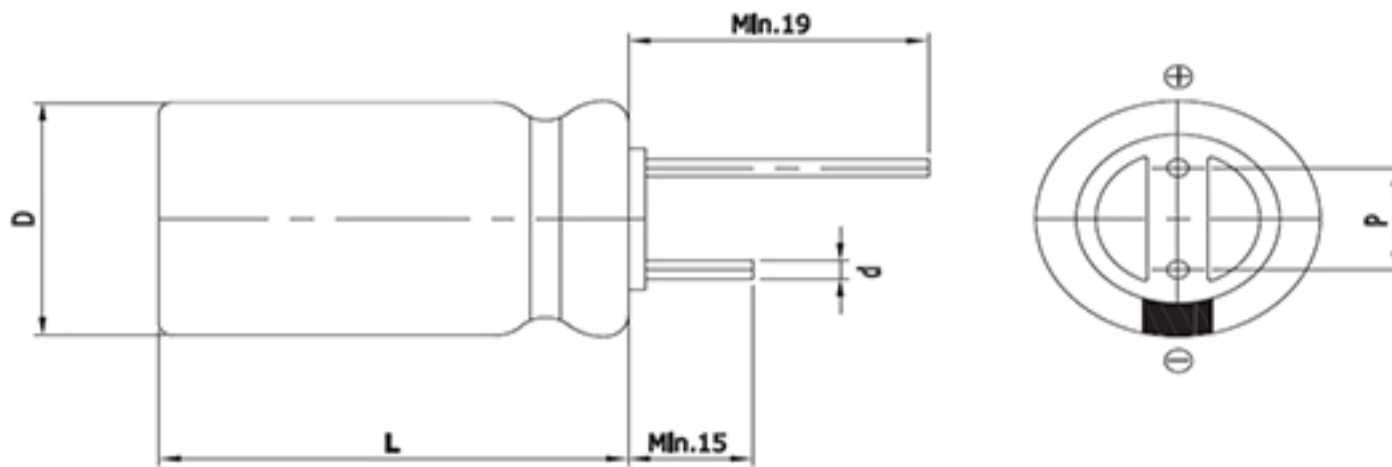

D (Φ)	12.5 +1.0Max
L (mm)	20.0 ±1.5
d (Φ)	0.6 ±0.1
P (mm)	5.0±0.5

Specification

Item		Characteristics						
Product series		EDLC						
Rated Voltage (V_R)		3.0V						
Operating Temperature		-40 ~ +65°C						
Capacitance Tolerance		-10 ~ +30%						
High Temperature Load Life		After 1,000 hours at V_R loaded under +65°C, capacitors meet the following criteria.						
		Capacitance Change		≤ 30% of initial value				
		ESR		≤ 2 times of specified value				
		85°C Temperature		Max. 2.4V				
Cycle Life Characteristics		Cycle		Over 500,000				
		ΔC		≤ 30% of initial value				
		ESR		≤ 2 times of specified value				
		Method		Cycle of Charge/discharge from V_R to $1/2V_R$				
Shelf Life		3 Years No Electrical Charge, Temperature below 25°C (ΔC : ≤ 10% of initial value / ΔESR : ≤ 50% of specified value)						
Part Number	Rated Voltage (V)	Capacitance (F)	ESR (mΩ)		Max. Current (A)	Leakage Current (mA, 72hr)		Size (mm) D x L
			AC(1kHz)	DC		@2.7V	@3.0V	
VEC 3R0 106 QD	3.0	10	40	60	9.0	0.020	0.030	13 x 20