

Features

EDLC (Electric Double Layer Capacitor)

- High Power Density (Low ESR)
- Over 500,000 cycle life (semi-permanent)
- Short-term Peak Power assist applications
- RoHS compliant



Drawing

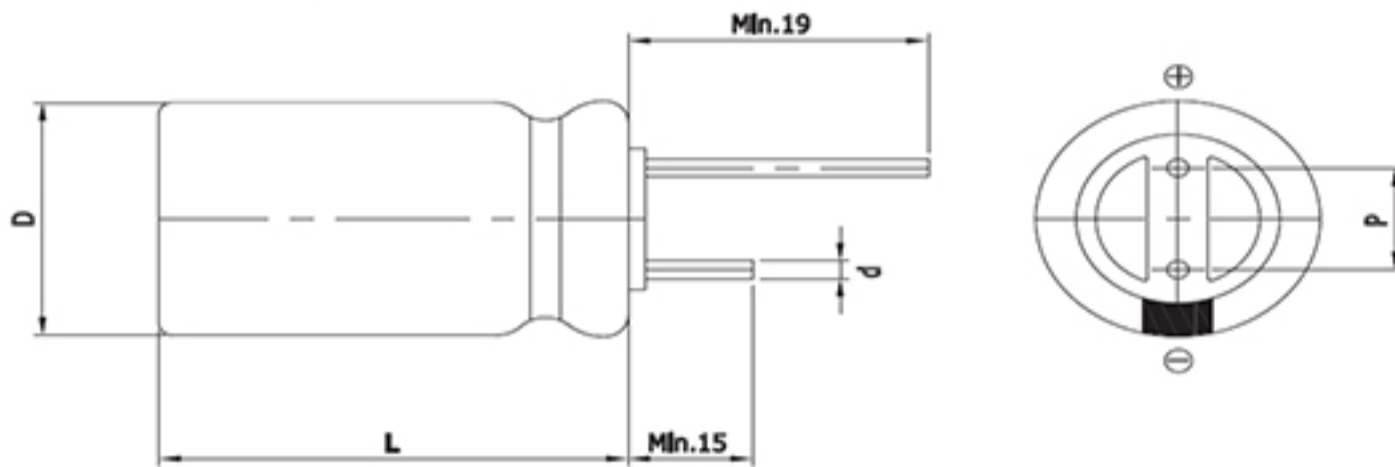

D (Φ)	12.5 +1.0Max
L (mm)	25.0 ±1.5
d (Φ)	0.6 ±0.1
P (mm)	5.0±0.5

Specification

Item	Characteristics	
Product series	EDLC	
Rated Voltage (V_R)	3.0V	
Operating Temperature	-40 ~ +65°C	
Capacitance Tolerance	-10 ~ +30%	
High Temperature Load Life	After 1,000 hours at V_R loaded under +65°C, capacitors meet the following criteria.	
	Capacitance Change	≤ 30% of initial value
	ESR	≤ 2 times of specified value
	85°C Temperature	Max. 2.4V
Cycle Life Characteristics	Cycle	Over 500,000
	ΔC	≤ 30% of initial value
	ESR	≤ 2 times of specified value
	Method	Cycle of Charge/discharge from V_R to $1/2V_R$
Shelf Life	3 Years No Electrical Charge, Temperature below 25°C (ΔC : ≤ 10% of initial value / ΔESR : ≤ 50% of specified value)	

Part Number	Rated Voltage (V)	Capacitance (F)	ESR (mΩ)		Max. Current (A)	Leakage Current (mA, 72hr)		Size (mm) D x L
			AC(1kHz)	DC		@2.7V	@3.0V	
VEC 3R0 156 QG	3.0	15	30	45	13.0	0.030	0.045	13 x 25

* Max. Current : 1 sec. discharge to $1/2V_R$