

2.7V 7F (1020)

Features

EDLC (Electric Double Layer Capacitor)

- High Power Density
- Over 500,000 cycle life (semi-permanent)
- Short-term Peak Power assist applications
- RoHS compliant
- Long-term reliability improved at high temperature and humidity



Drawing

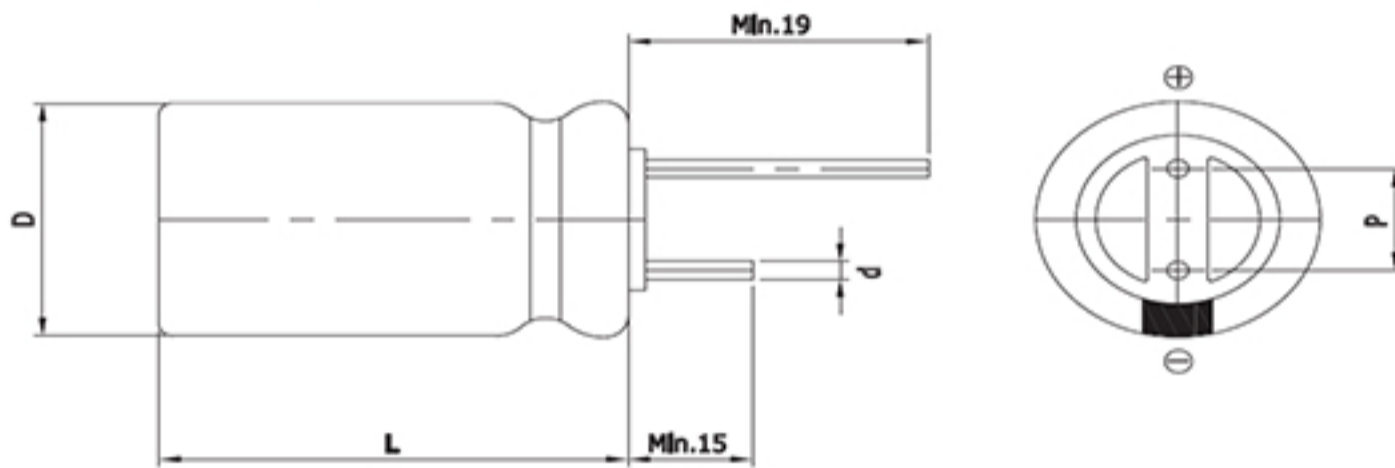

D (Φ)	10. +1.0 Max
L (mm)	20.0 ±1.5
d (Φ)	0.6 ±0.1
P (mm)	5.0 ±0.5

Specification

Item		Characteristics	
Product series		EDLC	
Rated Voltage (V_R)		2.7V	
Operating Temperature		-40 ~ +65°C	
Capacitance Tolerance		-10 ~ +30%	
High Temperature Load Life		After 1,000 hours at V_R loaded under +65°C, capacitors meet the following criteria.	
		Capacitance Change	≤ 30% of initial value
		ESR	≤ 2 times of specified value
		85°C Temperature	Max. 2.3V
Cycle Life Characteristics	Cycle	Over 500,000	
	ΔC	≤ 30% of initial value	
	ESR	≤ 2 times of specified value	
	Method	Cycle of Charge/discharge from V_R to $1/2V_R$	
Shelf Life		3 Years No Electrical Charge, Temperature below 25°C (ΔC : ≤ 10% of initial value / ΔESR : ≤ 50% of specified value)	

Part Number	Rated Voltage (V)	Capacitance (F)	ESR (mΩ)		Max. Current (A)	Leakage Current (mA, 72hr)	Size (mm)
			AC(1kHz)	DC			D x L
WEC 2R7 705 QG	2.7	7	65	110	5.0	0.014	10 x 20

* Max. Current :1 sec. discharge to $1/2V_R$