

Hybrid Capacitor 2.3V 800F



FEATURES

- Characteristics of EDLC and pseudo-capacitor
- Higher capacitance, 2 times of EDLC
- Semi-permanent, quick charge and discharge than batteries
- Suitable for long-term with low current backup applications
- UL and ISO/TS certificated, RoHS compliant
- Radial design with 4-pin snap-in terminal type



DIMENSIONS

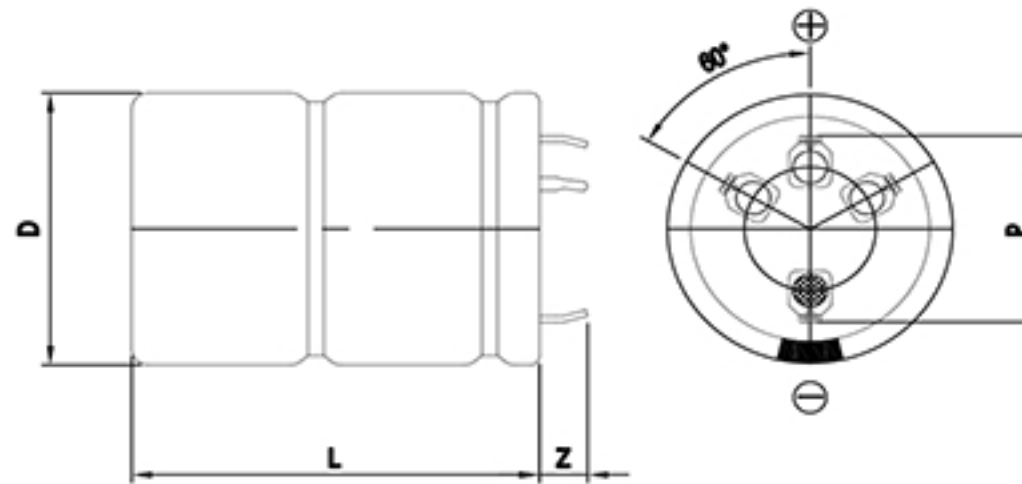

Dimensions in mm			
D +1.5 Max	L ± 2.0	Z ± 1.0	P ± 0.2
Φ35.0	72.0	6.0	23.0

This drawing is not to be scaled.

SPECIFICATIONS

Part Number	Rated Voltage, V_R (V)	Rated Capacitance (F)	AC ESR 1kHz (mΩ)	DC IR (mΩ)	Maximum Current (A)	Leakage Current (mA)	Stored Energy (J)	Dimension D x L (mm)	Weight (g)
VHC 2R3 807 QG	2.3	800.	10.00	15.00	12.5	1.600	2,116.0	35.0 x 72.0	94.5

* Maximum Current: 60 seconds discharge to $\frac{1}{2} \cdot V_R$

* Leakage Current: After 72hours at V_R and 25°C

Item	Characteristics	Remarks
Rated Voltage(V_R)	2.3V	Cut-off voltage: 0.9V
Capacitance Tolerance	-10 ~ +30%	
Operating Temperature ($T_{min} \sim T_{max}$)	-25 ~ +60 °C	$ \Delta cap \leq 30\%$ of initial value at 25 °C $ \Delta ESR \leq 100\%$ of specified value at 25 °C After 1,000 hours application of V_R at T_{max}
Storage Temperature	-20 ~ +70 °C	
Cycle Life	100,000 cycles	$ \Delta cap \leq 30\%$ of initial value at 25 °C $ \Delta ESR \leq 100\%$ of specified value at 25 °C Cycles from V_R to $\frac{1}{2} \cdot V_R$ under constant current at 25 °C
Shelf Life	2 years	$ \Delta cap \leq 10\%$ of initial value at 25 °C $ \Delta ESR \leq 50\%$ of specified value at 25 °C Without electrical charge under T_{max}