

	<h1>Approval sheet</h1>	Document number	VNP-MTPS-002
		Date of preparation	2019.06.17.
	<h2>Content</h2>	Revision number	0
		Page	1

1. Purpose
2. Product composition and recommendation of Ambient Condition
 - 2-1. Product composition
 - 2-2. Recommendation of Ambient Condition
3. General Specification
4. Drawing and size, part number, code number, sleeve
 - 4-1. Drawing and size
 - 4-2. Part number
 - 4-3. Code number
 - 4-4. Sleeve
5. Packaging
6. Measurement of the product
 - 6-1. Measurement condition
 - 6-2. Reference of measurement methods
 - 6-3. Discharge capacitance
 - 6-4. Internal resistance
 - 6-4-1. AC ESR
 - 6-4-2. DC Resistance
 - 6-5. Leakage current
 - 6-6. Cycle characteristic
7. Soldering
 - 7-1. Note
 - 7-2. Wave soldering
 - 7-3. Manual soldering
 - 7-4. Reflow soldering
8. Note when using

	<h1>Approval sheet</h1>	Document number	VNP-MTPS-002
		Date of preparation	2019.06.17.
	<h1>Specification</h1>	Revision number	0
		Page	2

1. Purpose

This document states the specification, the measurement method of performance, and other notes about our product.

2. Product composition and recommendation of Ambient Condition

2-1. Product composition

This product is composed of as followed.

- ① Electrode : The appearance of electrode is electrode material (activated carbon or metal oxide) adhered to the aluminum foil. Electrodes consist of positive and negative polarity.
- ② Separator : It uses to separate between the positive and negative electrodes.
- ③ Electrolyte : It is organic liquid that salt dissolved in. Electrode and separator are soaked in electrolyte.
- ④ Aluminum case : It contains an electrode, a separator, and an electrolyte.
- ⑤ Rubber stopper : It is used for sealing cells. Positive and negative terminals come out through it.

2-2. Recommendation of Ambient Condition

This product can be used in the range of $-40^{\circ}\text{C} \sim 65^{\circ}\text{C}$ temperature condition.

We recommend to be used between $5^{\circ}\text{C} \sim 35^{\circ}\text{C}$ of the temperature range about 1 atm.

This product can be used in 0~75%RH humidity condition. However, we recommend to be used in low humidity.

	<h1>Approval sheet</h1>	Document number	VNP-MTPS-002
		Date of preparation	2019.06.17.
	<h1>Specification</h1>	Revision number	0
		Page	3

3. General Specification

Item		Specification / Condition	
Part number		VEC 2.7V SNAP IN	
Rated voltage (V)		2.7V	
Environmental condition	Operating	Temperature (°C)	-40 ~ +65
		Humidity (%RH)	Max. 75
		Atmosphere (atm)	0.85 ~ 1.15
	Storage	Temperature (°C)	-40 ~ +70
		Humidity (%RH)	Max. 75
		Atmosphere (atm)	0.8 ~ 1.2
Temperature characteristics		Capacitance change : ±5% of initial measured value, ESR : max. 2 times of specified value	
Endurance (temp. : 65 ±2°C, applied voltage : 2.7V DC, test time : 1000h)		Capacitance change : max. 30% of initial measured value, ESR : max. 2 times of specified value	
Shelf life (temp. : 70 ±2°C, no voltage applied, test time : 2 years)		Capacitance change : max. 10% of initial measured value, ESR : ±50% of specified value	

Part Number	Rated Voltage (V)	Capacitance (F)	ESR(mΩ)		Max Current(A)	Leakage Current (mA, 72hr)	Size(mm) D x L	Weight (g)	Volume (ml)
			AC(1kHz)	DC					
VEC2R7107QG	2.7	100	6.0	10.0	65.0	0.200	22x45	20.0	17.1
VEC2R7227QG		220	4.5	7.0	115.0	0.440	25x70	38.0	34.3
VEC2R7367QG		360	3.0	4.5	185.0	0.720	35x62	70.0	59.6
VEC2R7407QG		400	3.0	4.5	190.0	0.800	35x72	80.0	69.2
VEC2R7507QG		500	3.0	4.5	205.0	1.0	35x82	96.0	78.9

※ Max current (A) = (1/2 CV)/(CR_(DC Max.))+1)

	<h1>Approval sheet</h1>	Document number	VNP-MTPS-002
		Date of preparation	2019.06.17.
	<h1>Specification</h1>	Revision number	0
		Page	4

4. Drawing and size, part number, code number, sleeve

4-1. Drawing and size

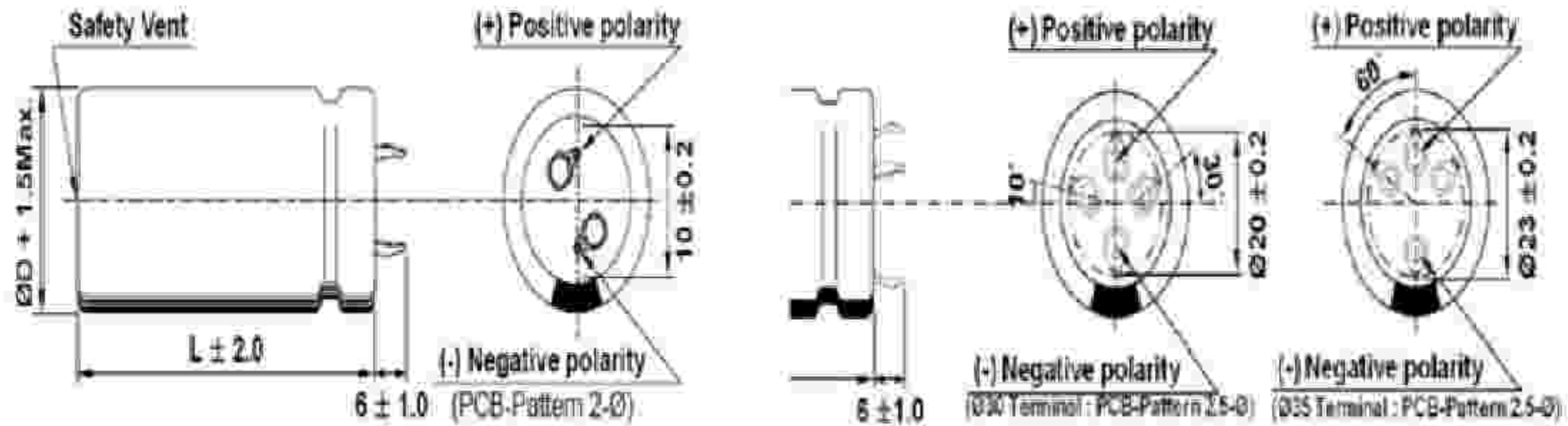

4-2. Part number

The part number consists of 12 digit-numbers. Specific meaning of each digit is stated as follows.

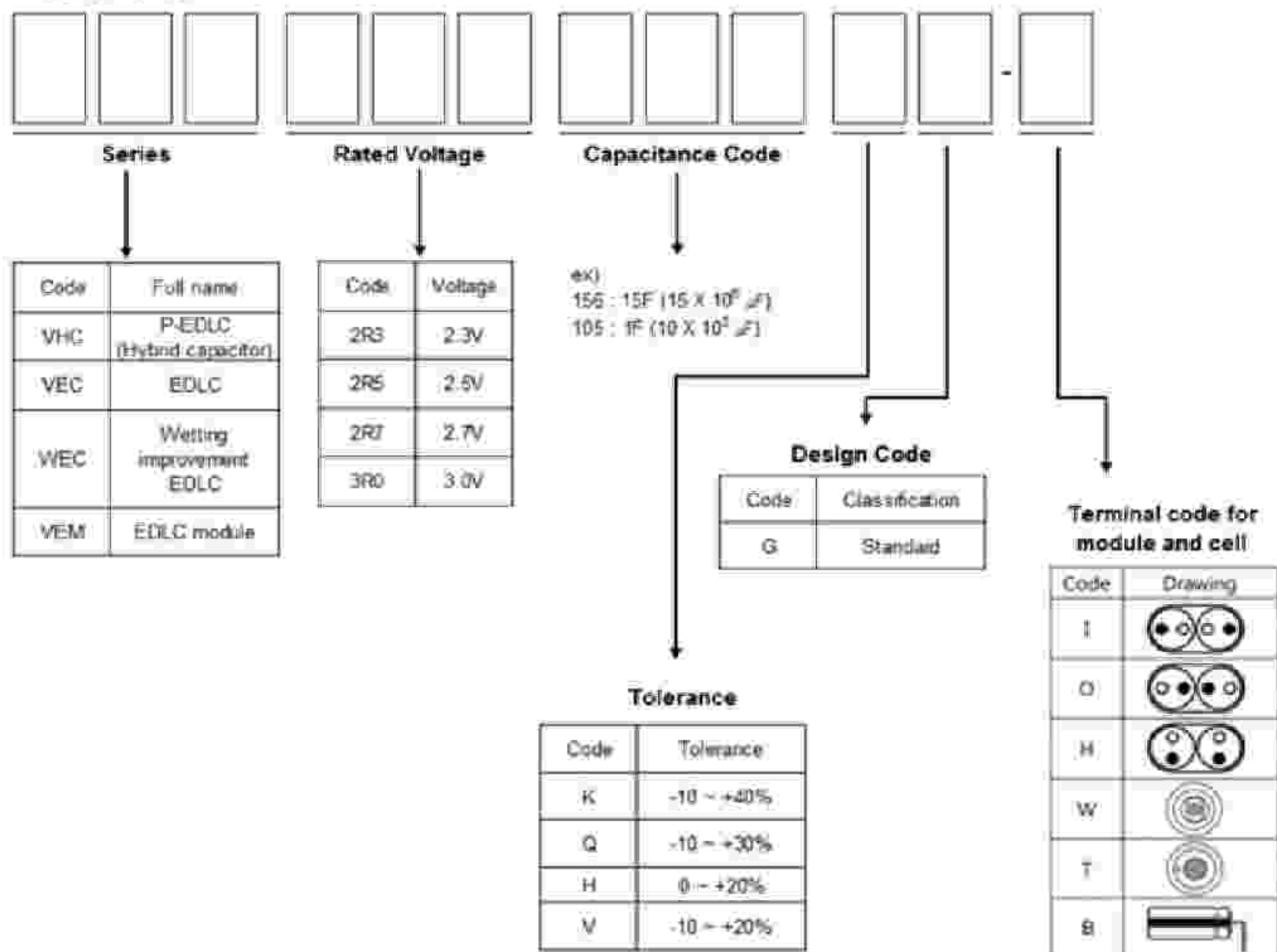

	<h1>Approval sheet</h1>	Document number	VNP-MTPS-002	
		Date of preparation	2019.06.17.	
	<h1>Specification</h1>		Revision number	0
			Page	5

4-3. Code number

The code number, which marked in the sleeve, consists of 4-digit number. Specific meaning of each digit is stated as follows.

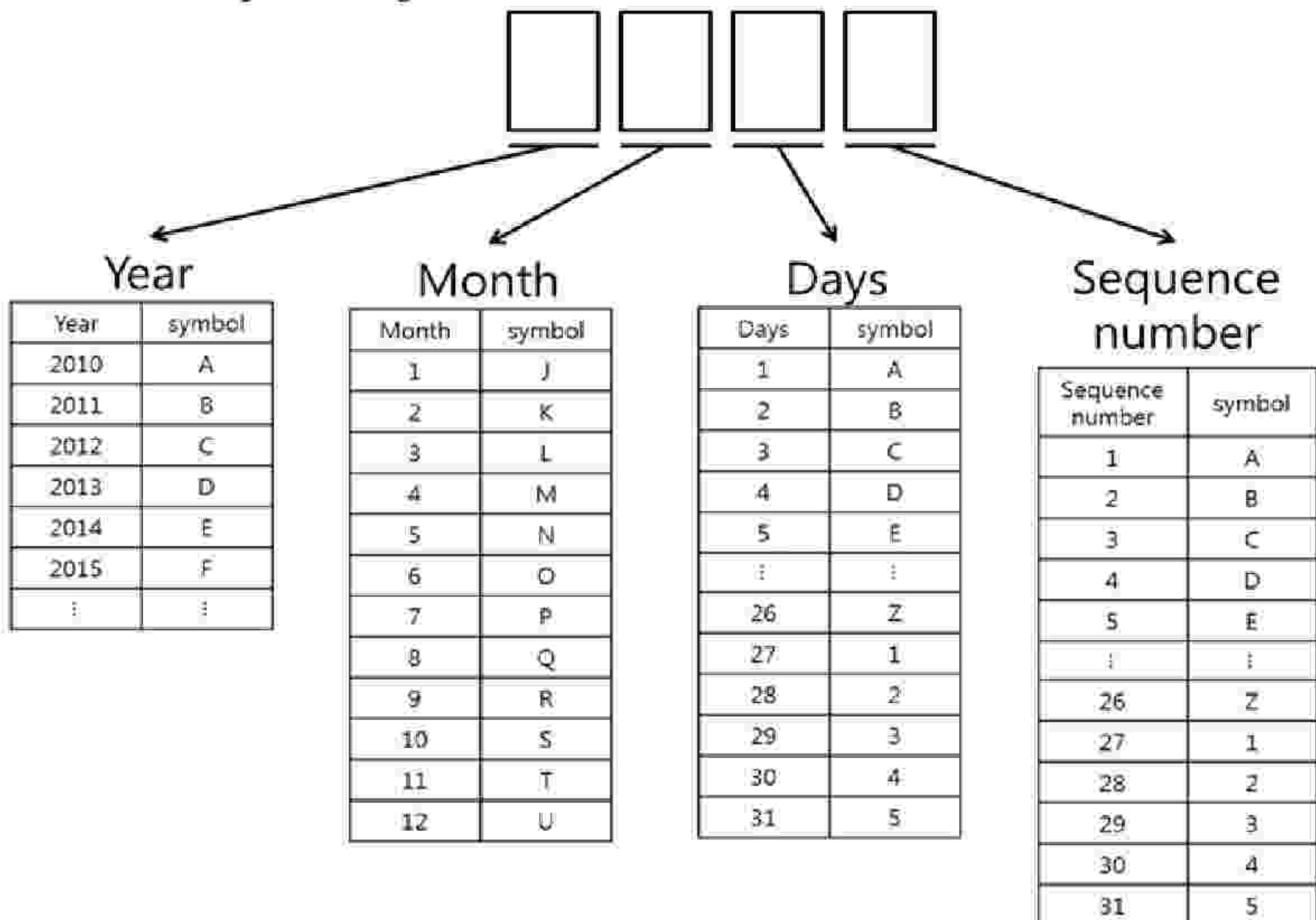

4-4. Sleeve



rated voltage
&
rated capacitance



code
number

polarity (-)

	<h1>Approval sheet</h1>	Document number	VNP-MTPS-002
		Date of preparation	2019.06.17.
	<h1>Specification</h1>	Revision number	0
		Page	7

6. Measurement of the product

6-1. Measurement condition

Except temperature characteristic test, the ordinary conditions of temperature and pressure are 25°C and 1 atm (or 101.3kPa).

6-2. Reference of measurement methods

The measurement method refers to IEC 62391-1 (Fixed electric double-layer capacitors for use in electronic equipment—Part 1: Generic specification).

6-3. Discharge capacitance

Discharge capacitance can be calculated by using the constant current discharge method.

Circuit diagram is as below.

(1) Circuit diagram

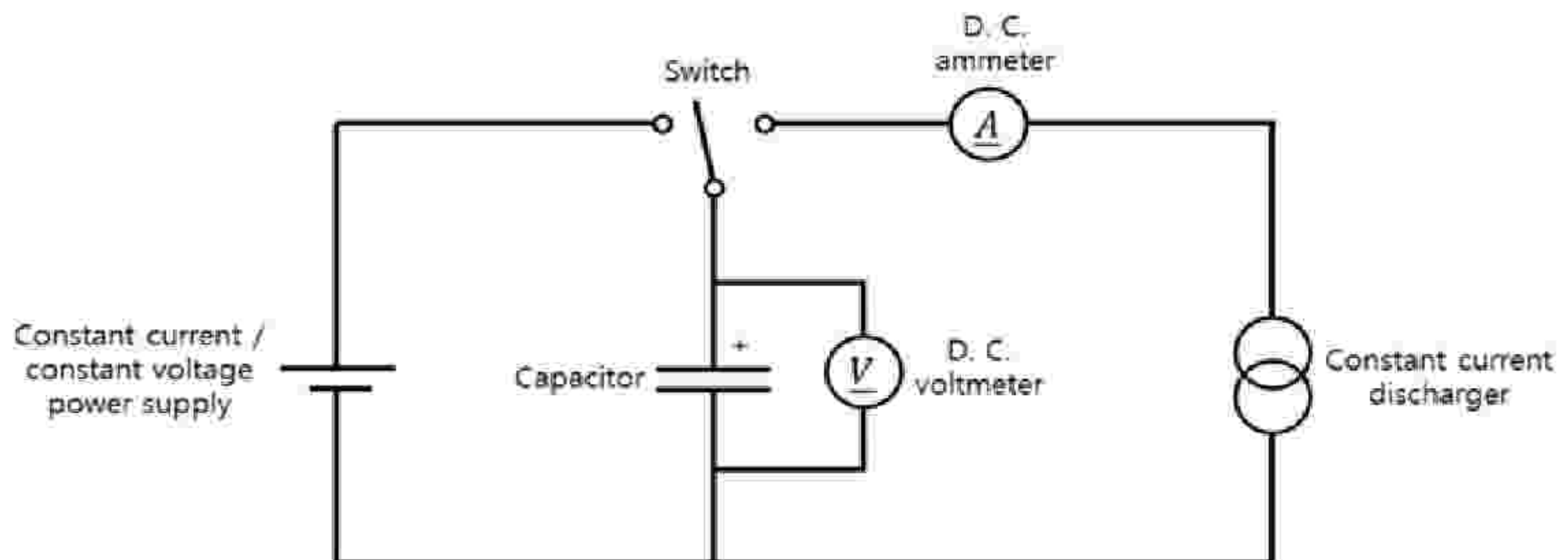



Approval sheet

Specification

Document number	VNP-MTPS-002
Date of preparation	2019.06.17.
Revision number	0
Page	8

(2) Method

- 1) Set the value of current and voltage of the power supply to perform the procedure with constant current and constant voltage accurately.
The value of charge voltage is rated voltage and the value of charge current is calculated as follows:
 $10 \text{ mA/F} \times \text{rated capacity (F)}$.
- 2) Set the value of discharge current of constant current discharger. Discharge current is calculated as follows:
 $1 \text{ mA/F} \times \text{rated capacity (F)}$.
- 3) Make close circuit with the power supply and start constant current/constant voltage charging procedure.
- 4) After constant voltage charge for 30min has finished, change over the switch to the constant current discharger.
- 5) After the test, charge-discharge curve draws below, and discharge capacitance is calculated with the following equation.

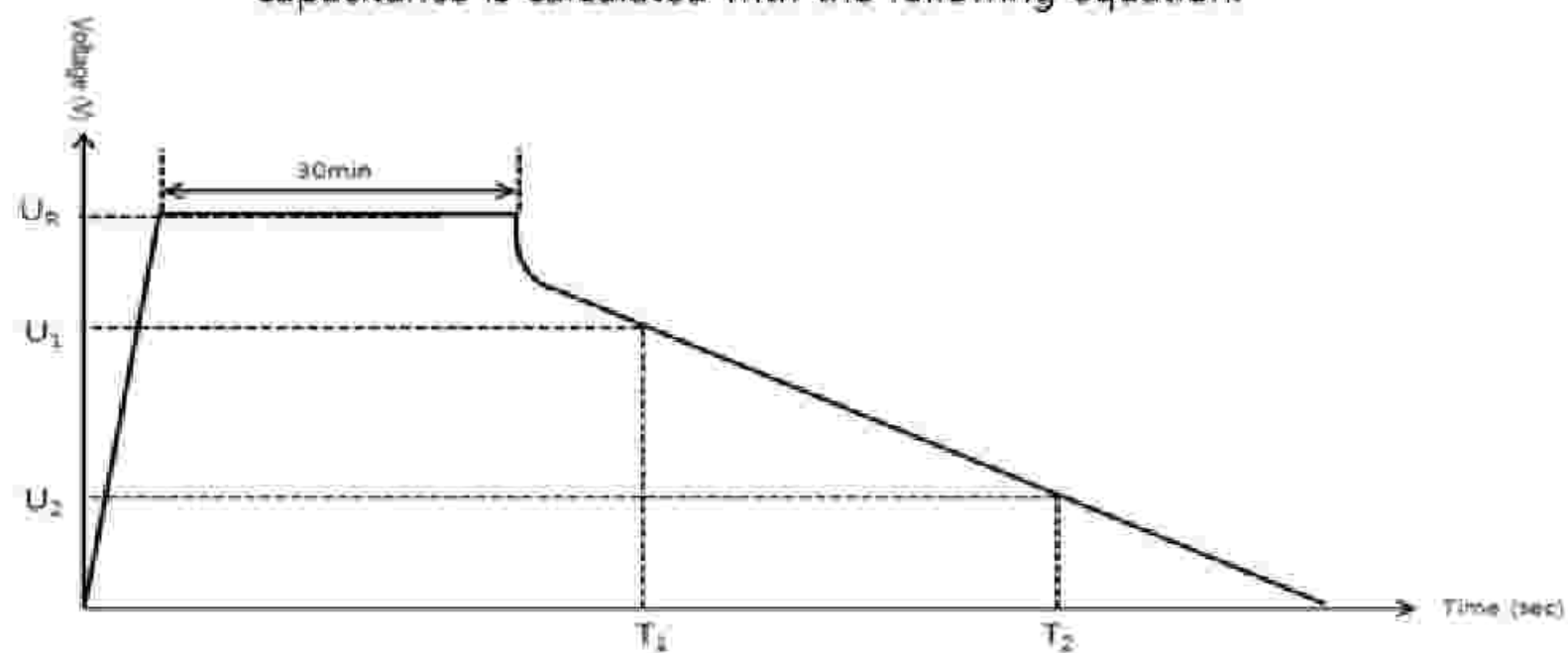

$$C = \frac{I \times (T_2 - T_1)}{U_1 - U_2}$$

where,

- C : discharge capacitance (F)
- I : discharge current (A)
- U_1 : voltage (V) of $U_R \times 0.8$
- U_2 : voltage (V) of $U_R \times 0.4$
- T_1 : time (s) from discharge start to reach U_1
- T_2 : time (s) from discharge start to reach U_2

	<h1 style="margin: 0;">Approval sheet</h1>	Document number VNP-MTPS-002
	<h1 style="margin: 0;">Specification</h1>	Date of preparation 2019.06.17.
		Revision number 0
		Page 9

6-4. Internal resistance

6-4-1. AC ESR

AC ESR can be measured by using a four probe impedance analyzer. The value of AC frequency is 1 kHz.

Circuit diagram is as below.

(1) Circuit diagram

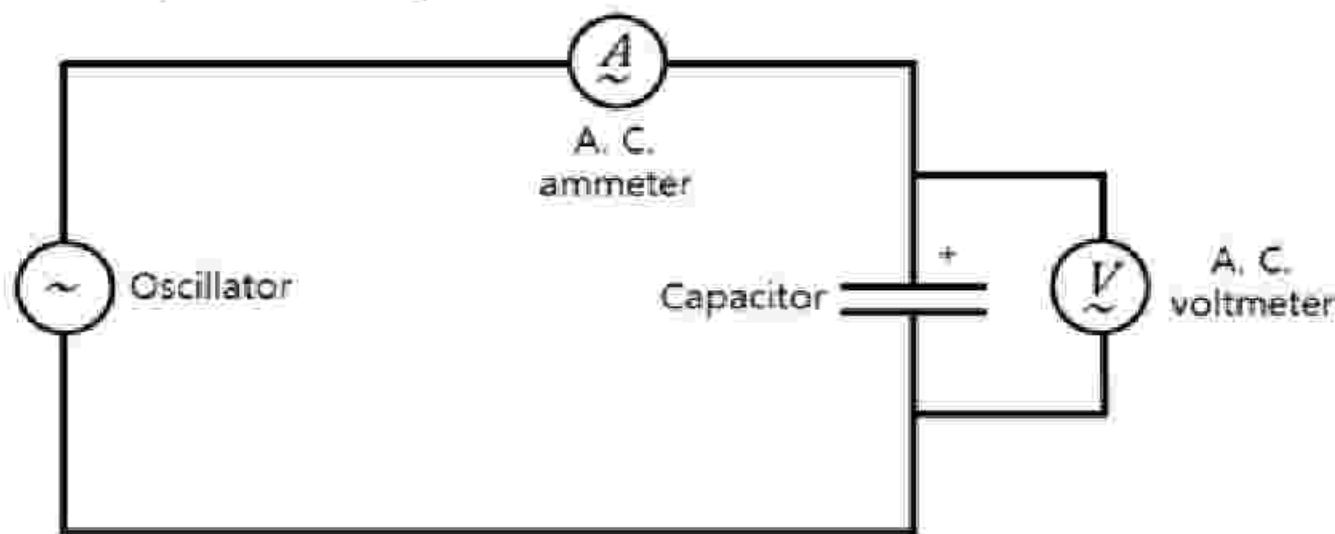

(2) AC ESR calculation

$$R_x = \frac{U}{I}$$

where,

R_x : A. C. internal resistance (Ω)

U : Effective value of A. C. voltage (V. r. m. s.)

I : Effective value of A. C. current (A. r. m. s.)

Note

- The frequency of the measuring voltage shall be 1kHz.
- The A. C. current shall be from 1mA to 10mA.



Approval sheet

Specification

Document number	VNP-MTPS-002
Date of preparation	2019.06.17.
Revision number	0
Page	10

6-4-2. DC Resistance

DC Resistance can be calculated through constant current discharge. Refer to circuit diagram 6-3.

(1) Method

1) Set the value of current and voltage of the power supply to perform the procedure with constant current and constant voltage accurately.

The value of charge voltage is rated voltage and the value of charge current is calculated as follows:

$10 \text{ mA/F} \times \text{rated capacity}$.

2) Set the value of discharge current of constant current discharger. Discharge current is calculated as follows:

$0.1 / \text{the maximum value of DC ESR suggested in this specification}$

3) Make close circuit with the power supply and start constant current/constant voltage charging procedure.

4) After constant voltage charge for 30min has finished, change over the switch to the constant current discharger.

When the switch changes over, it is necessary that interval time of switch (or rest time) is 1 sec.

5) After the test, charge-discharge curve draws below, and ΔU is calculated with the following equation.

ΔU_3 = voltage when beginning to discharge - voltage 10 ms after starting to discharge.

6) The value of DC ESR is calculated with the following equation.

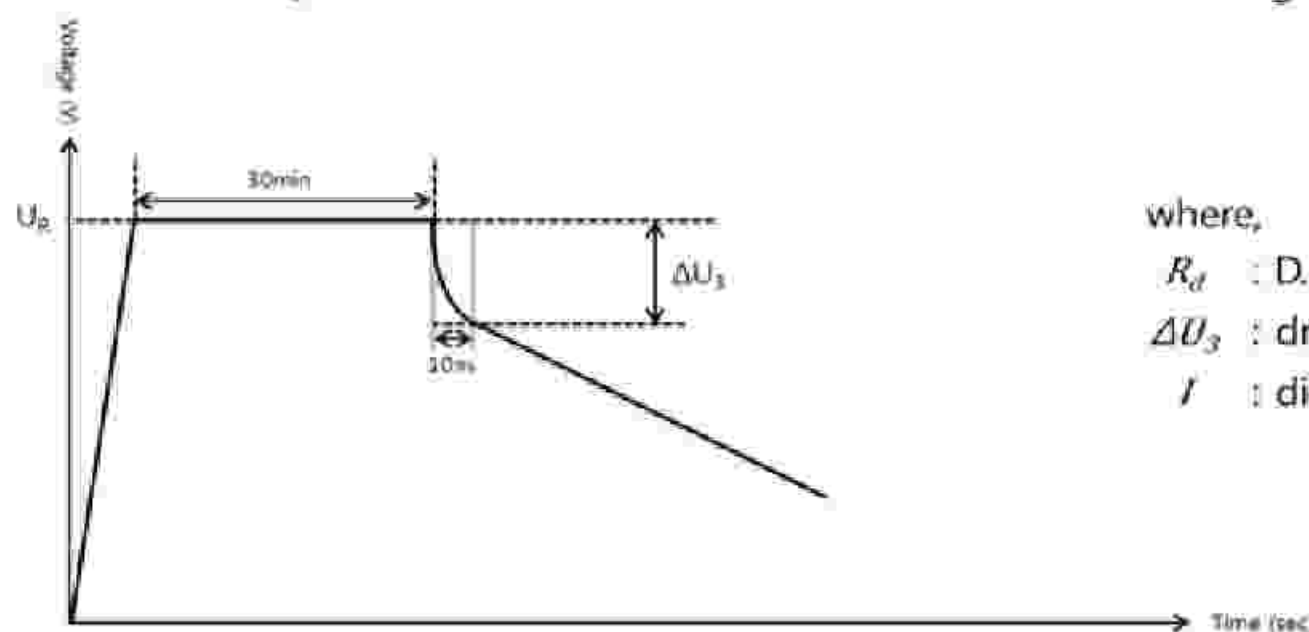

$$R_d = \frac{\Delta U_3}{I}$$

where,

R_d : D. C. internal resistance (Ω)

ΔU_3 : drop voltage (V)

I : discharge current (A)

	<h1>Approval sheet</h1>	Document number	VNP-MTPS-002
		Date of preparation	2019.06.17.
	<h1>Specification</h1>	Revision number	0
		Page	11

6-5. Leakage current

Leakage current can be measured as the following circuit diagram.

(1) Circuit diagram

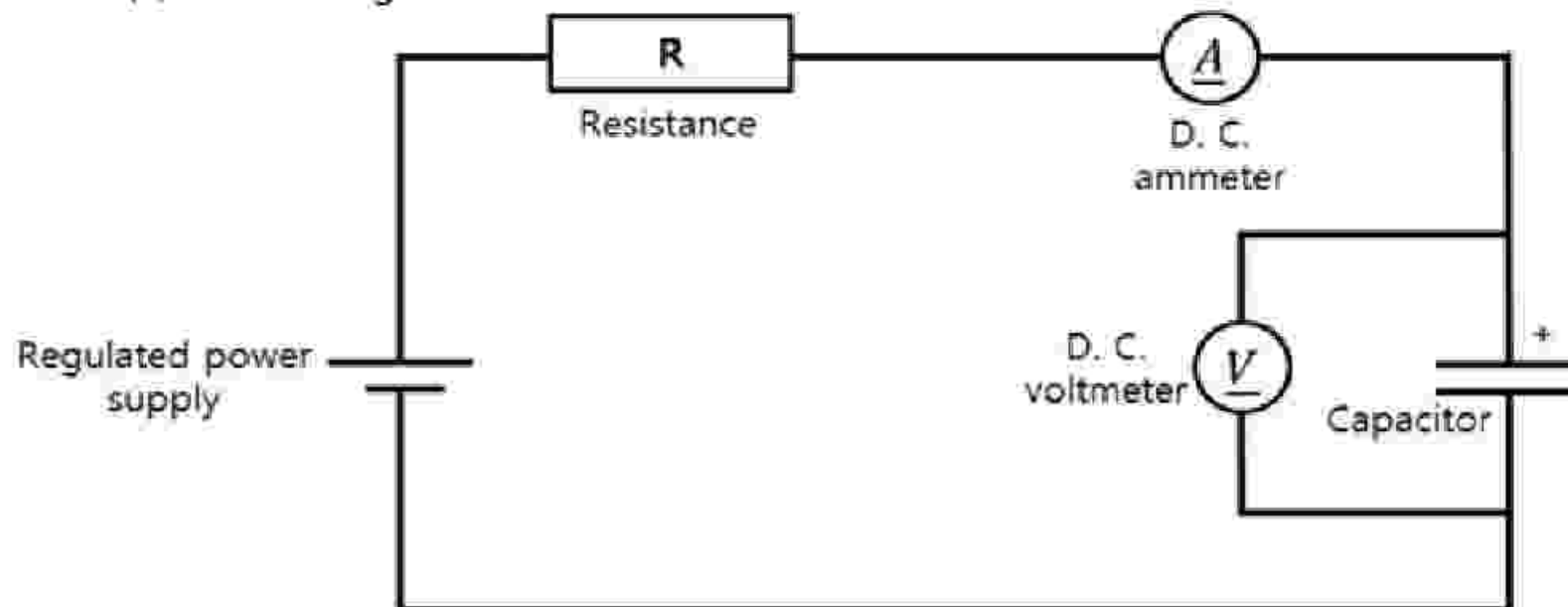

(2) Method

- 1) Before the test, the product must be fully discharged. Duration time of full discharge is 1~24 h.
- 2) Set the value of charge voltage of a power supply which is rated voltage.
- 3) Connect the protective resistor of 1000Ω or less in the circuit, this resistor can be selected depending on the condition in order to charge-up to reach 95% of rated voltage within 30 min.
- 4) Charge the product with power supply.
- 5) After 72h of the voltage reaching 95% of rated voltage, measure the value of the current.



Approval sheet

Specification

Document number	VNP-MTPS-002
Date of preparation	2019.06.17.
Revision number	0
Page	12

6-6. Cycle characteristic

Cycle characteristic of the product can be observed by using the constant current charge and discharge method.

Refer to circuit diagram 6-3.

(1) Measurement

The measurement process is as follows.

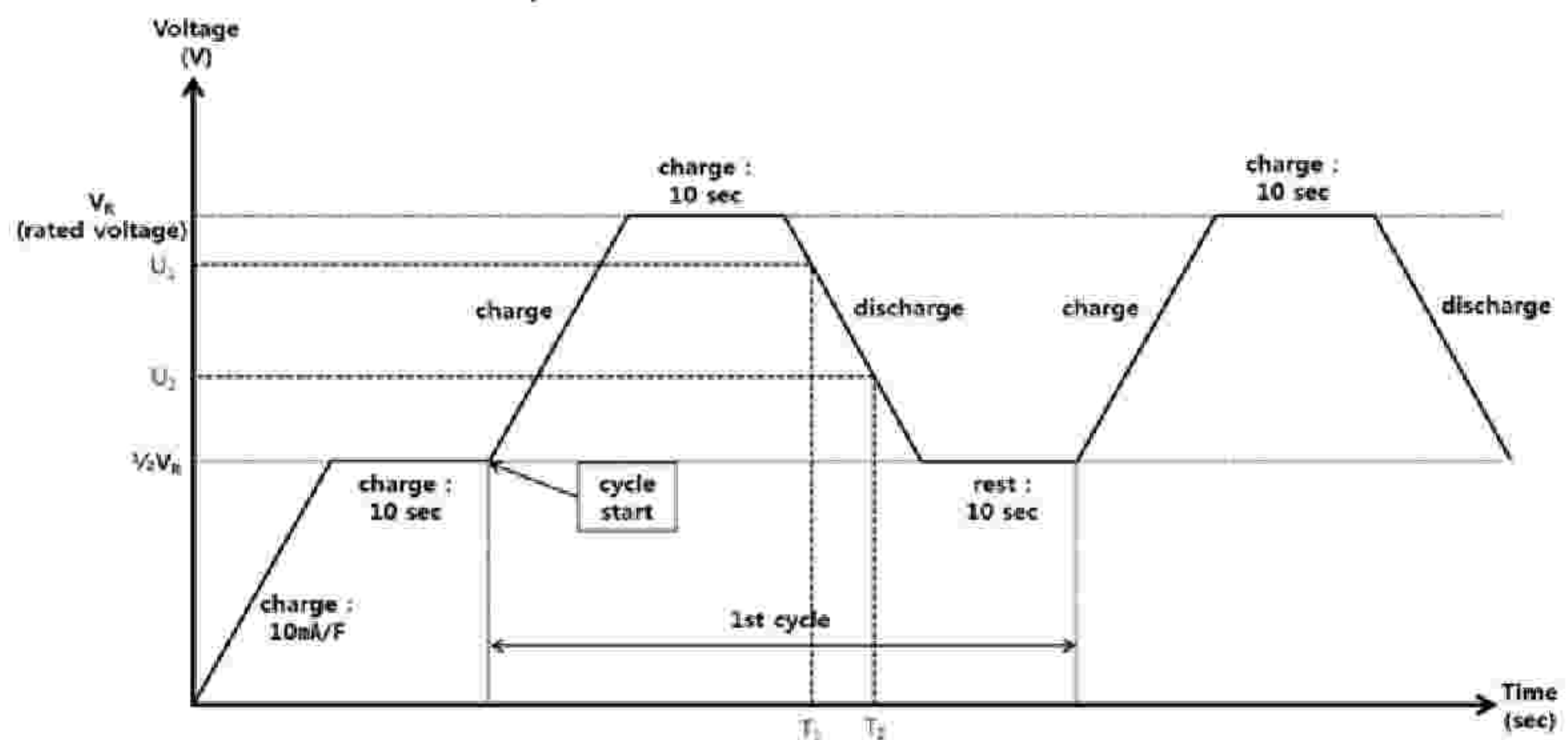

- 1) Charge the product at constant current. The value of charge voltage is half of the rated voltage and the value of charge current is calculated as follows:
 $10 \text{ mA/F} \times \text{rated capacity}$.
- 2) Charge the product at constant voltage (half value of rated voltage) during 10 sec.
- 3) Charge the product at constant current. The value of charge voltage is the rated voltage and the value of charge current is calculated as follows:
 $(\text{rated discharge capacitance} \times 1/2 \times \text{rated voltage}) / 20$
- 4) Charge the product at constant voltage (rated voltage) during 10 sec.
- 5) Discharge the product at constant current. The value of discharge voltage is half of the rated voltage and the value of discharge current is calculated as follows:

	<h1>Approval sheet</h1>	Document number	VNP-MTPS-002
		Date of preparation	2019.06.17.
	<h1>Specification</h1>	Revision number	0
		Page	13

(rated discharge capacitance X 1/2 X rated voltage) / 20

- 6) Rest for 10 sec.
- 7) Repeat the process 3) ~ 6).
- 8) The process 3) ~ 6) is defined as 1 cycle and after the processes 1) ~ 3) is defined as the starting point.
- 9) During the measurement of cycle characteristic, discharge capacitance of nth time is calculated as follows.

$$C = \frac{I \times (T_2 - T_1)}{U_1 - U_2}$$

where,

- C : discharge capacitance (F)
- I : discharge current (A)
- U_1 : voltage (V) of $U_R \times 0.9$
- U_2 : voltage (V) of $U_R \times 0.7$
- T_1 : time (s) from discharge start to reach U_1
- T_2 : time (s) from discharge start to reach U_2

	<h1>Approval sheet</h1>	Document number	VNP-MTPS-002	
		Date of preparation	2019.06.17.	
	<h1>Specification</h1>		Revision number	0
			Page	14

7. Soldering

7-1. Note

If the soldering temperature is too high or soldering time is too long, the characteristic of the product can be deteriorated or swollen.

If the soldering temperature is high or soldering time is long, sleeve can be cracked, dented, or melted.

The soldering process must be proceeded after connecting the PCB and the product.

Also, when connecting PCB and the product, the product must be covered up the sleeve.

Do not dip the product into melted solder.

During the soldering process, melted lead must be contacted with terminal of the product only.

7-2. Wave soldering

Recommended condition

Solder composition : 99.3Sn-0.7Cu

Solder pot temperature : 250~270°C

Max. Exposure time : 10 sec

Max. preheat temperature (PCB bottom) : 160°C

Max. preheat time (above temperature 100°C) : 60 sec

7-3. Manual soldering

Recommended condition

Temperature of the soldering rod tip : 350°C (Pb solder) and 400°C (Pb-free solder)

Max. soldering duration : 5sec

Do not touch the product with the soldering rod.

7-4. Reflow soldering

Do not use reflow soldering of the product.

	<h1>Approval sheet</h1>	Document number	VNP-MTPS-002
		Date of preparation	2019.06.17.
	<h1>Specification</h1>	Revision number	0
		Page	15

8. Note when using

- 1) This specification guarantees the quality and features of our product as stated in its suggested conditions.
- 2) Do not take the product apart or damage at random.
In this case, we do not compensate for the product either materially or monetarily.
- 3) Polarity
 - This product has polarity (positive and negative poles) so it can be used accordingly. The negative pole is marked on the sleeve of the product.
- 4) Overvoltage and overcurrent
 - It is recommended that the product should be used at below the rated voltage. When used at over the rated voltage, it can burst or its life span can be shortened.
 - In case of connecting more than 2 units for modules, we recommend to lower the operating voltage per unit by Min. 10% from the rated voltage for the sake of safer voltage balancing (e.g. 2.43V per unit in case of 2.7V series).
 - It is recommended that the product should be applied and used at below the maximum current. When used at over the maximum current, it can burst or its life span can be shortened.
- 5) Working conditions and storage
 - The life of this product can be shortened by working conditions, such as working temperature, humidity, air pressure, among others.
 - Do not keep the product in an environmental condition that is not recommended in this document.
 - Do not expose the product to over 75% humidity. When exposed for a long time, its life can be shortened or it can cause malfunction.
 - Do not use or keep the product in the temperature range that is higher than what is recommended in this document. Its life can be shortened or it can cause malfunction.

	<h1>Approval sheet</h1>	Document number	VNP-MTPS-002
		Date of preparation	2019.06.17.
	<h1>Specification</h1>	Revision number	0
		Page	16

- Do not use or keep the product in the atmosphere that is composed of highly corrosive substances (for example, the environment that is exposed to halogen substances, such as Cl, F, or halogen compounds, nitrogen substances or nitrogen compounds, sulfur substances or sulfur compounds, hexavalent chrome, arsenic, among others).
- Do not use or keep the product around Alkalis or Acids.
- When storing the product, avoid direct sunlight and keep it indoors where dust is little and humidity is low.

6) Washing and drying

- It is prohibited to wash and dry the product.
- Be careful not to touch the product with water, oil, organic solvent, or compounds containing such liquids.
- Do not dry the product applying heat or energy.

7) Connecting PCB

- When connecting the product with PCB, it is prohibited to take actions to fix the product (For example, actions, such as drilling a hole to connect a wire with PCB through the hole or bending lead wire excessively to fix it).
- After connecting the product with PCB, do not move or shake it.
- Do not pull, shake, fold, or twist the lead wire.
- When connecting the product after bending the lead wire with PCB, bend the lead wire using appropriate fixing jig and device before mounting the product on PCB so that the product is not damaged by shock and force.
- After connecting the product with PCB, do not wash it with a PCB cleansing solution. Also, it is prohibited to touch the product with highly corrosive liquid. It can affect its life or cause malfunction.
- Before connecting the product in series or in parallel, discuss the technical matter with us fully.
- When connecting the product with PCB, do not place the product near the components which generate heat while being operated on PCB.
- Before connecting the product with products of other companies in series or in parallel, discuss the technical matter with us fully.

	<h1>Approval sheet</h1>	Document number	VNP-MTPS-002
		Date of preparation	2019.06.17.
	<h1>Specification</h1>	Revision number	0
		Page	17

- When soldering the product to connect, conform to the content of this specification.
- When connecting the product with PCB, discharge it below 0.1 V for EDLC model.

8) Do not remove or damage the sleeve of the product.

In this case, we do not compensate for the product either materially or monetarily.

9) Safety

- When the product becomes hot or gives off a burning smell, or when its cell burst when using it, turn off the circuit and stop using it immediately.
- We do not take any responsibility for the result from the following behaviors.
 - ① Holding the fully charged product.
 - ② Taking the product apart or damaging it.
 - ③ Removing or damaging the sleeve of the product.
 - ④ Other uses that are prohibited from this specification or against working conditions guaranteed in it.

10) Shelf life

- If EDLC is stored without charge & discharge for over 2 years, it is expected that the capacitor may degrade and performance may be lost by around 10%. This can be recovered over time with constant use.

11) Transportation

- EDLC and P-EDLC are safe to ship by any mode. They are REACH & RoHS compliant. EDLC is shipped fully discharged, however there will be a residual charge with Max. 0.5V for a recovery voltage.

12) Others

- The product specified in this document is intended for use in the general application such as memory backup, energy storage, instantaneous power assist etc. However, please contact us for our technical advice or support when the product is used to the application such as transportation or mobility system (automotive drive control, train control, vessel control, aerial vehicle etc.), traffic signal, disaster prevention equipment, medical devices etc. which may directly cause fatal danger, bodily harm or loss of human life.

	<h1>Approval sheet</h1>	Document number	VNP-MTPS-002
		Date of preparation	2019.06.17.
	<h1>Warranty</h1>	Revision number	0
		Page	18

Even though the product is applied to the general application, it is strongly recommended that, when the application requires high level of safety or reliability, the additional protection circuit should be added as necessary after through evaluation of safety.

- Please note that, unless there is the prior written agreement signed by VINATech and your company, the scope of warranty for the product is limited to the product itself which is delivered to your company and VINATech shall not be responsible for any damages caused by a fault or defect in our product.

13) If you have any other inquiries, please e-mail us at the following address.

E-mail: hycap@vina.co.kr

※ When received the approval sheet for the specific part from VINATech to confirm the final product specification, please send back with the confirmation signature

If the approval sheet with the confirmation signature is not arrived within 30days after the request of the confirmation, it is considered that all the specification on the approval sheet is agreed.