

Electrostatic Discharged Protection Devices (ESD) Data Sheet

Description

UET26A05L05-IP38 is surge rated diode arrays designed to protect high speed data interfaces. It has been specifically designed to protect sensitive components which is connected to data and transmission lines from overvoltage caused by electrostatic discharge (ESD), electrical fast transients (EFT), and lightning.

The unique design of the device incorporates one surge rated, and four data lines. Low capacitance steering diodes and a TVS diode in a single package. The low capacitance array configuration allows the user to protect four high speed data or transmission lines.



Contact : ±30kV
Air : ±30kV



Features

- IEC61000-4-2 ESD 30KV Air, 30KV contact compliance
- SOT23-6L surface mount package
- Protects four high-speed data lines and one power line
- Array of surge rated, low capacitance diodes
- Working voltage: 5V
- Low leakage current
- Low clamping voltage
- Solid-state silicon avalanche technology
- RoHS compliant
- Solder reflow temperature: Pure Tin-Sn, 260~270°C
- Flammability rating UL 94V-0
- Meets MSL level 1, per J-STD-020
- Marking: B 05E

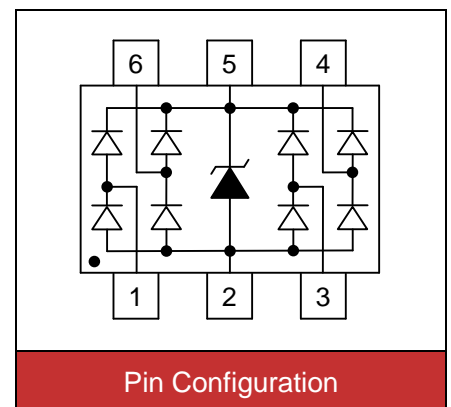

Applications

- | | |
|--|---|
| <ul style="list-style-type: none"> ● USB power and data line protection ● 10/100/1000 Ethernet ● Video line protection ● I²C bus protection | <ul style="list-style-type: none"> ● WAN/LAN equipment ● ISDN S/T interface ● Microcontroller input protection ● Portable electronics |
|--|---|

Maximum Ratings

Rating	Symbol	Value	Unit
Peak pulse current (tp=8/20µs)	I _{PP}	38	A
ESD voltage (Contact discharge)	V _{ESD}	±30	kV
ESD voltage (Air discharge)		±30	
Storage & operating temperature range	T _{STG} , T _J	-55~+150	°C

Electrical Characteristics (T_J=25°C)

Parameter	Symbol	Condition	Min.	Typ.	Max.	Unit
Reverse stand-off voltage	V _{RWM}				5	V
Reverse breakdown voltage	V _{BR}	I _{BR} =1mA	6			V
Reverse leakage current	I _R	V _R =5V Each I/O pin			1	μA
Clamping voltage (tp=8/20μs)	V _C	I _{PP} =1A			9.8	V
Clamping voltage (tp=8/20μs)	V _C	I _{PP} =25A			25	V
Peak pulse current (tp=8/20μs)	I _{PP}				38	A
Off state junction capacitance	C _J	0Vdc, f=1MHz Between I/O pins and GND		5		pF

Applications Information

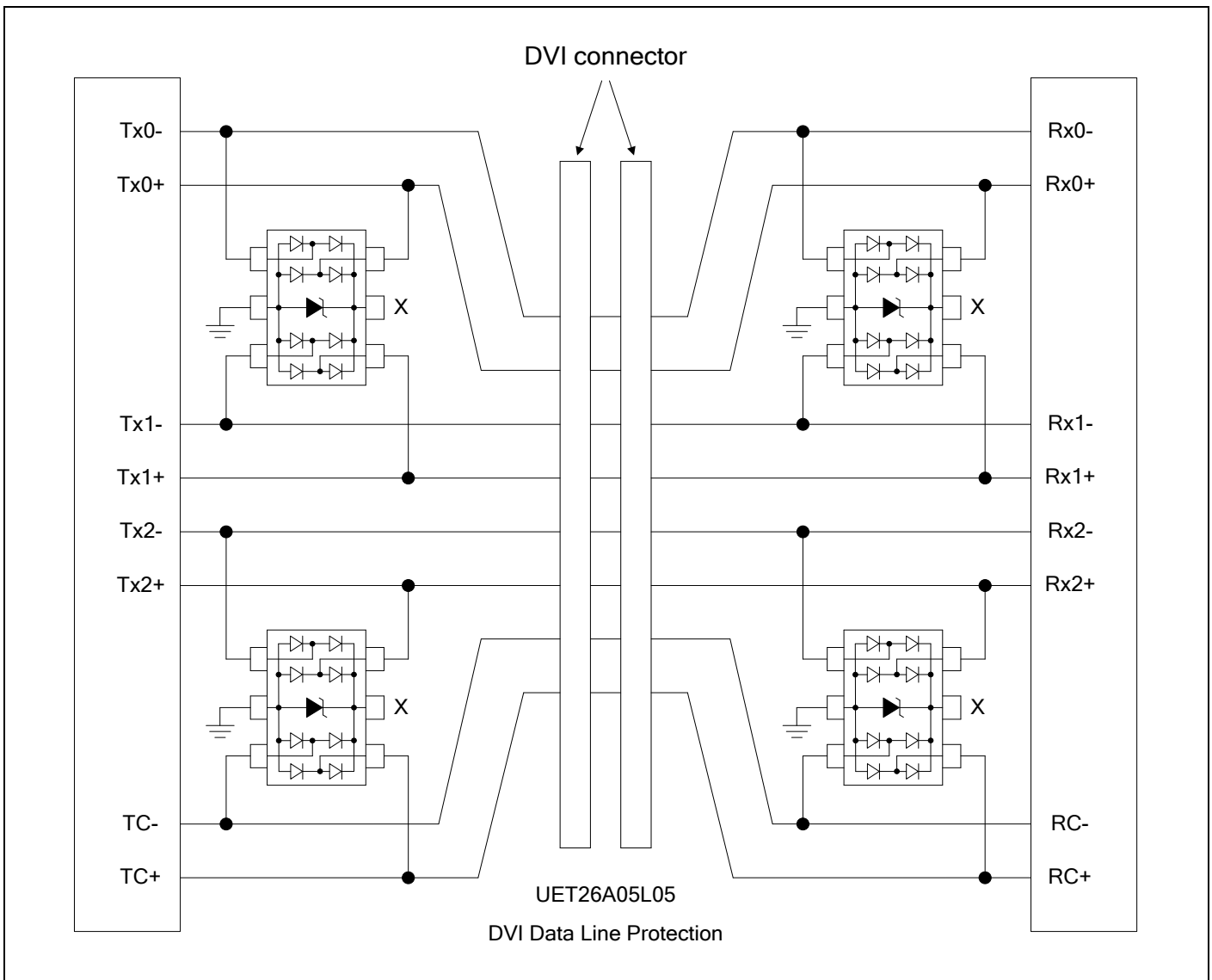

ESD Protection Standards

IEC61000-4-2

Interfaces of consumer electronic equipment are widely specified according to the International Electrotechnical Commission standard IEC61000-4-2. This standard is not targeted towards particular devices but towards general equipment, systems and subsystems that may be involved in electrostatic discharge. consists of a 150pF capacitor and a 330Ω series resistor representing the counterpart to the Device Under Test (DUT).

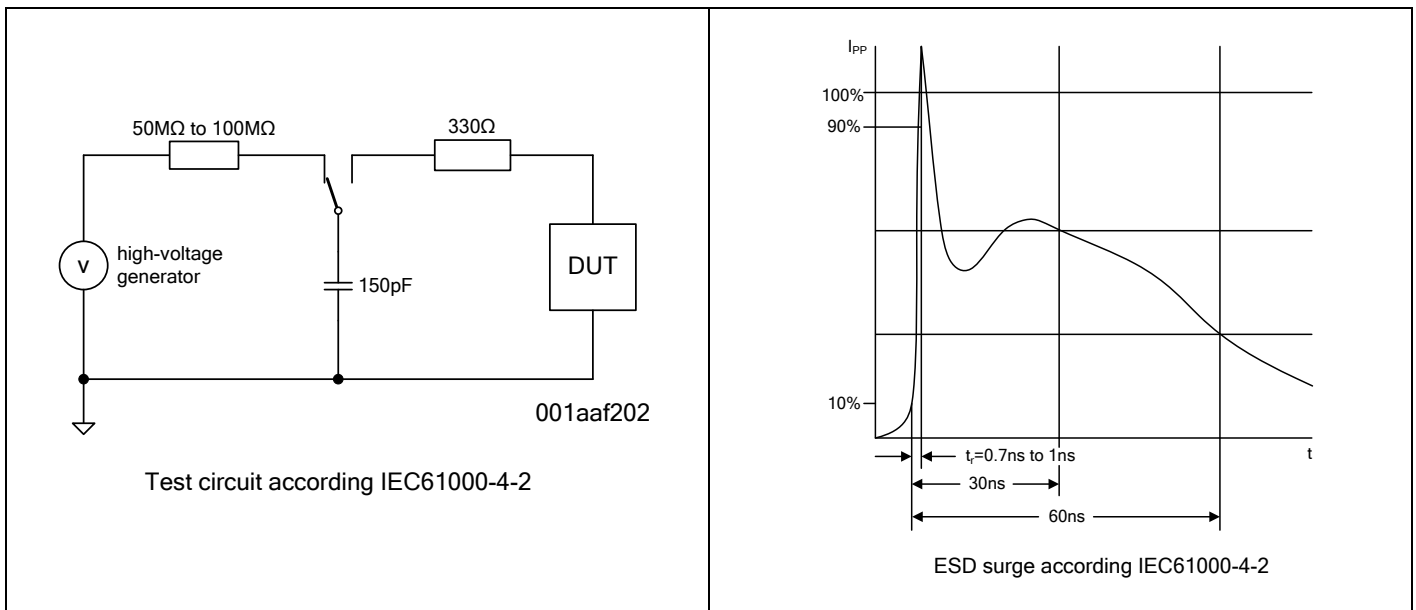

Human Body Model (HBM, MIL-883E method 3015.7)

The HBM standard simulates an ESD surge generated by human contact to electronic components.

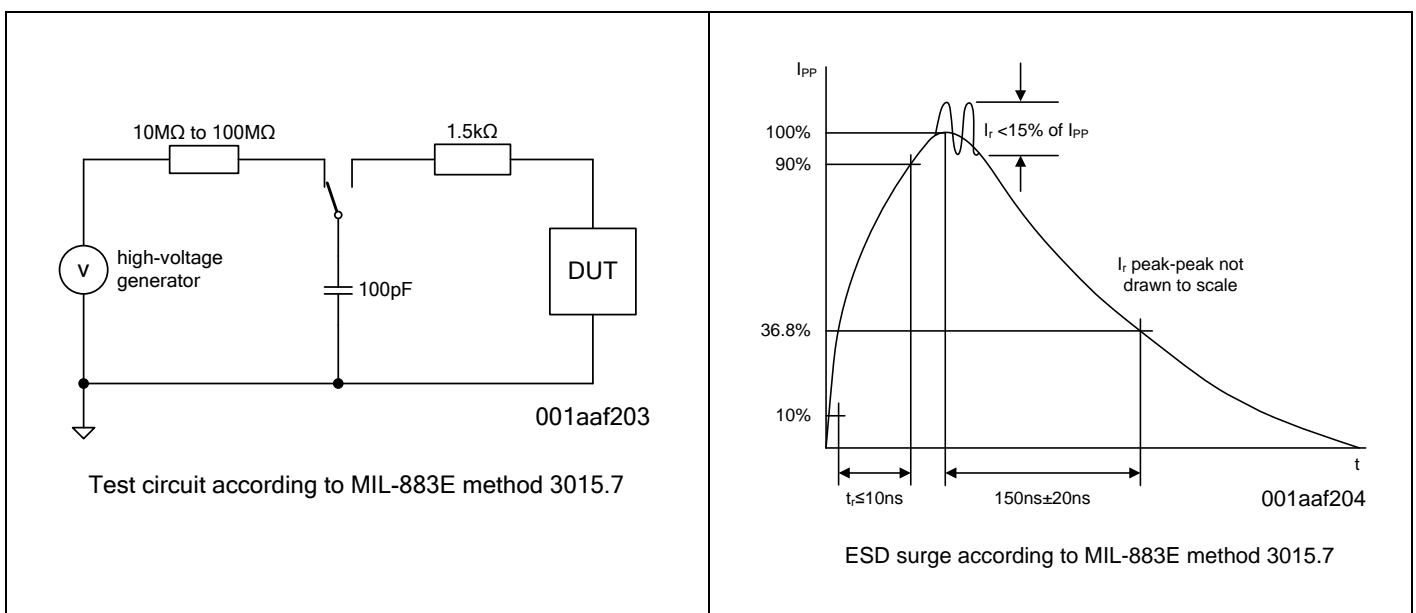

Recommended Soldering Conditions

Reflow Soldering

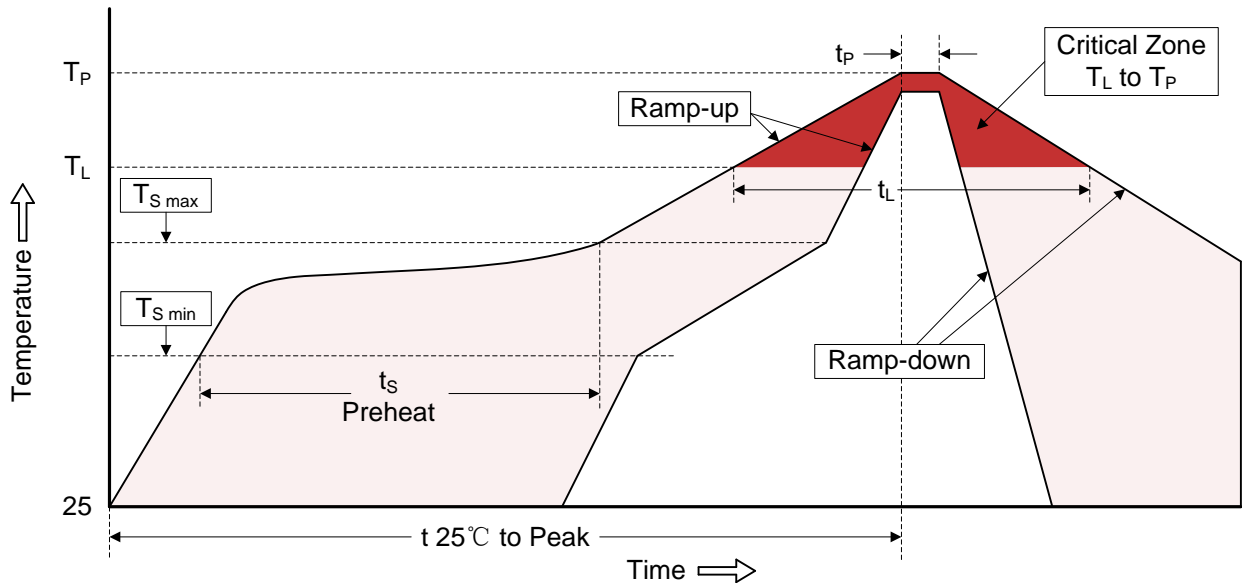

Recommended Conditions

Profile Feature	Pb-Free Assembly
Average ramp-up rate (T_L to T_P)	3°C/second max.
Preheat -Temperature Min ($T_{S\ min}$) -Temperature Max ($T_{S\ max}$) -Time (min to max) (t_s)	150°C 200°C 60-180 seconds
$T_{S\ max}$ to T_L -Ramp-up Rate	3°C/second max.
Time maintained above: -Temperature (T_L) -Time (t_L)	217°C 60-150 seconds
Peak Temperature (T_P)	260°C
Time within 5°C of actual Peak Temperature (t_P)	20-40 seconds
Ramp-down Rate	6°C/second max.
Time 25°C to Peak Temperature	8 minutes max.

Dimensions (SOT23-6L)

Symbol	Dimension			
	Millimeters		Inches	
	Min.	Max.	Min.	Max.
A	2.80	3.00	0.110	0.118
B	2.60	3.00	0.102	0.118
C	0.93	0.97	0.037	0.038
D	0.41		0.016	
E	1.50	1.70	0.059	0.067
F	0.11	0.19	0.004	0.007
G	-	0.10	-	0.004
H	0.40	-	0.016	-
J	1.00	1.20	0.393	0.047

Recommended Soldering Pad Layout

Packaging

Tape	Symbol	Dimension (mm)
	W	8.00±0.30
P0	4.00±0.10	
P1	4.00±0.10	
P2	2.00±0.10	
D0	Φ1.55±0.10	
D1	Φ1.05±0.05	
E	1.75±0.10	
F	3.50±0.10	
A	3.40±0.10	
B	3.20±0.10	
K	1.30±0.10	
t	0.25±0.05	
Reel	D	Φ178.0±2.0
	D2	Φ13.0
	W1	9.5
		Quantity: 3000PCS