

Electrostatic Discharged Protection Devices (ESD) Data Sheet

Description

Brightking's UES08A03L05 component is surge rated diode array designed to protect high speed data line interfaces. It has been specifically designed to protect sensitive components which are connected to data and transmission lines from overvoltage caused by electrostatic discharge (ESD), electrical fast transients (EFT), and lightning. The unique design of this device incorporates surge rated, low capacitance steering diodes and TVS diodes in a single package. During transient conditions, the steering diodes direct the transient either the position side of the power supply or to the ground.



Contact : ±30kV
Air : ±30kV



Features

- IEC61000-4-2 ESD 30KV Air, 30KV contact compliance
- SOIC-08 surface mount package
- Protects four I/O lines and one power line
- Working voltage: 3.3V
- Low leakage current
- Low capacitance and clamping voltage
- Solid-state silicon avalanche technology
- Lead Free/RoHS compliant
- Solder reflow temperature: Pure Tin-Sn, 260~270°C
- Flammability rating UL 94V-0
- Meets MSL level 1, per J-STD-020
- Marking: B A035

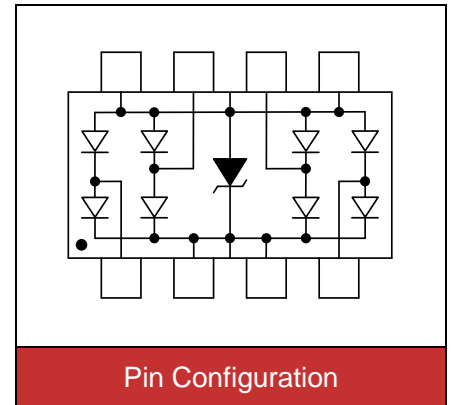

Applications

- Ethernet 10/100/ base T
- Firewire & USB protection
- Set Top Box (STB) protection
- Video card (DVI) protection
- T1/E1 secondary IC side protection
- T3/E3 secondary IC side protection
- HDSL secondary IC side protection
- IC bus protection
- Micro-controller line protection

Maximum Ratings

Rating	Symbol	Value	Unit
Peak pulse current (tp=8/20µs waveform)	I _{PP}	25	A
ESD voltage (Contact discharge)	V _{ESD}	±30	kV
ESD voltage (Air discharge)		±30	
Storage & operating temperature range	T _{STG} ,T _J	-55~+150	°C

Electrical Characteristics ($T_J=25^{\circ}\text{C}$)

Parameter	Symbol	Condition	Min.	Typ.	Max.	Unit
Reverse stand-off voltage	V_{RWM}				3.3	V
Reverse breakdown voltage	V_{BR}	$I_{BR}=1\text{mA}$	3.5			V
Reverse leakage current	I_R	$V_R=3.3\text{V}$ Each I/O pin			1	μA
Clamping voltage ($t_p=8/20\mu\text{s}$)	V_C	$I_{pp}=1\text{A}$		7.5		V
Clamping voltage ($t_p=8/20\mu\text{s}$)	V_C	$I_{pp}=5\text{A}$		9.8		V
Clamping voltage ($t_p=8/20\mu\text{s}$)	V_C	$I_{pp}=25\text{A}$		25		V
Off state junction capacitance	C_J	0Vdc, $f=1\text{MHz}$ Between I/O pins and GND			5	pF

Applications Information

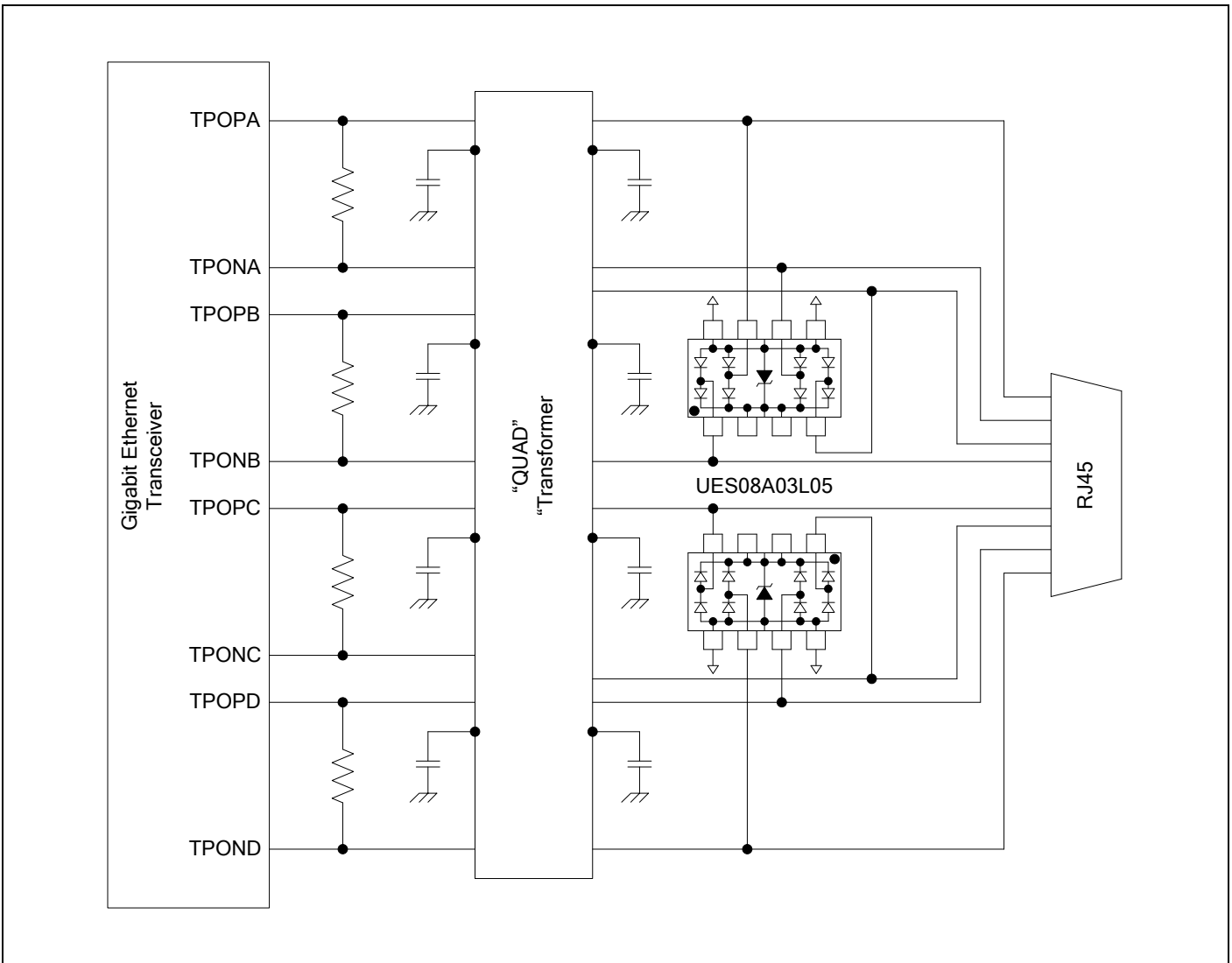

Typical Characteristics Curves

Figure 1. Pulse Waveforms

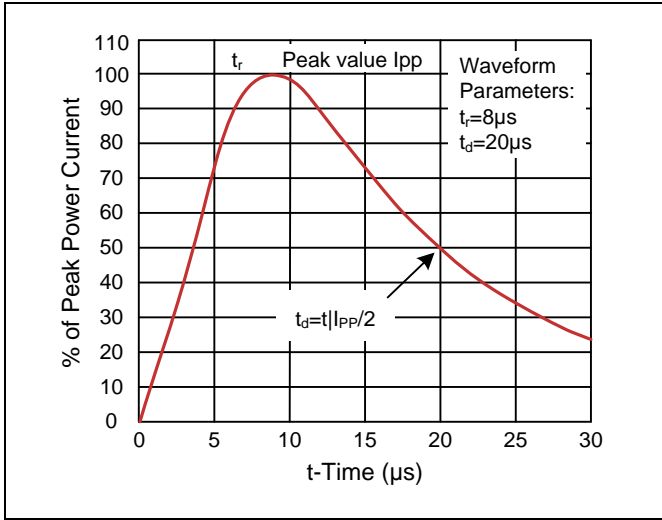

Figure 2. Clamping Voltage vs. Peak Pulse Current

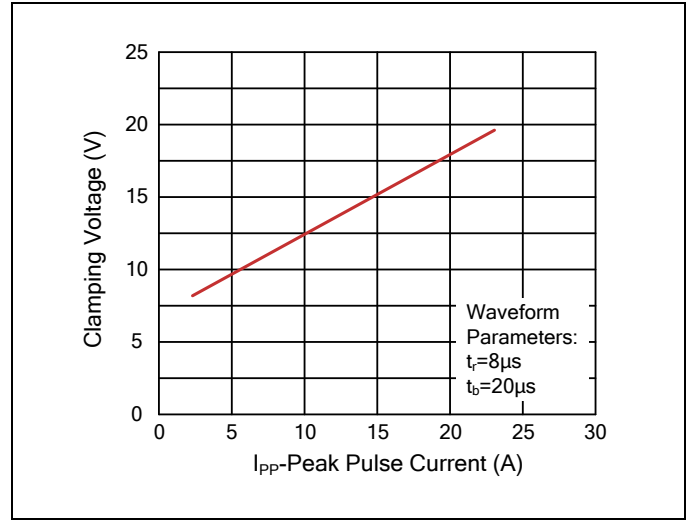
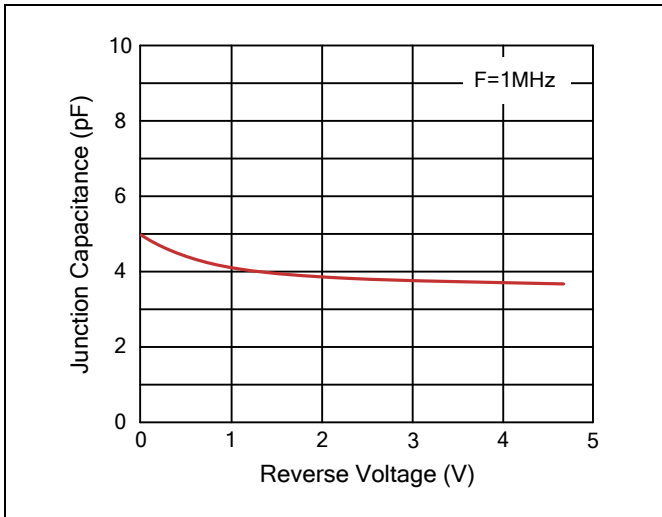
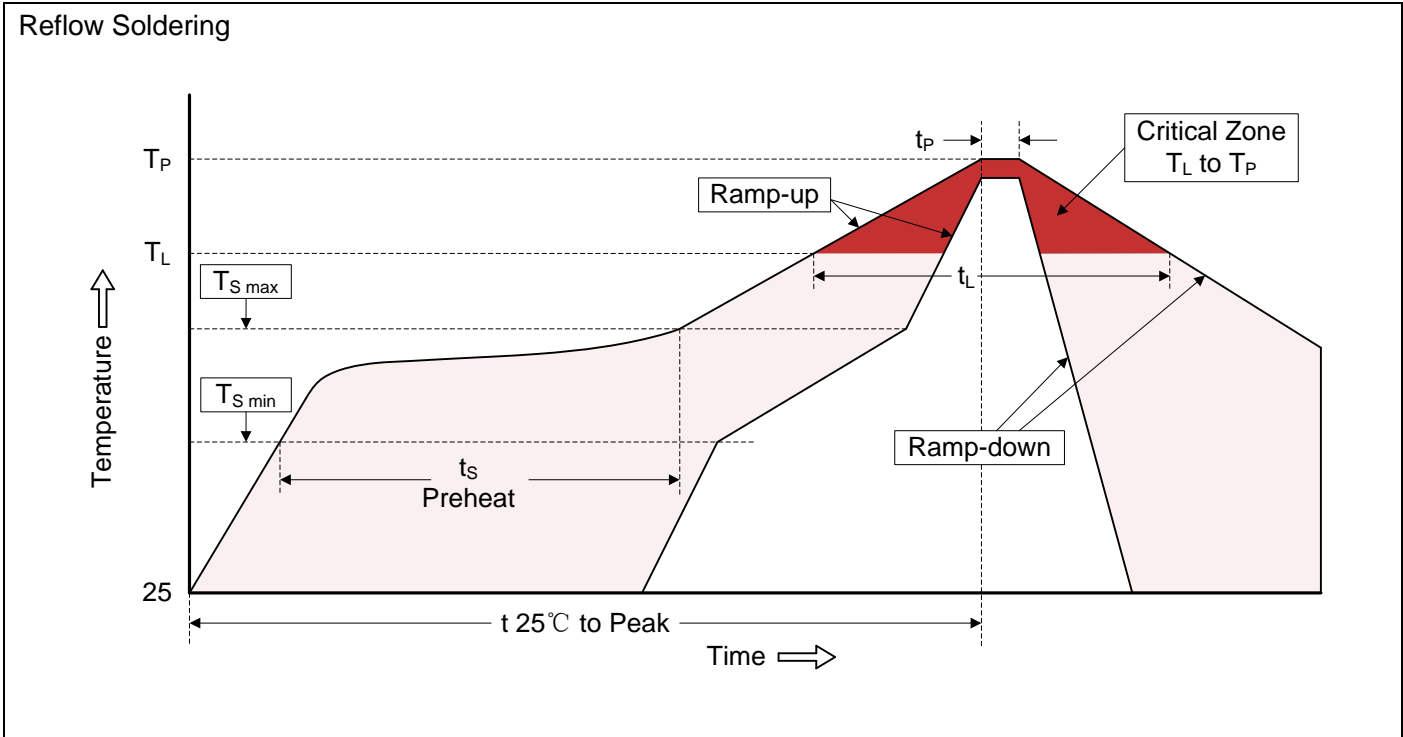

Figure 3. Capacitance vs. Reverse Voltage



Recommended Soldering Conditions



Recommended Conditions

Profile Feature	Pb-Free Assembly
Average ramp-up rate (T_L to T_P)	3°C/second max.
Preheat -Temperature Min ($T_{S\ min}$) -Temperature Max ($T_{S\ max}$) -Time (min to max) (t_s)	150°C 200°C 60-180 seconds
$T_{S\ max}$ to T_L -Ramp-up Rate	3°C/second max.
Time maintained above: -Temperature (T_L) -Time (t_L)	217°C 60-150 seconds
Peak Temperature (T_P)	260°C
Time within 5°C of actual Peak Temperature (t_p)	20-40 seconds
Ramp-down Rate	6°C/second max.
Time 25°C to Peak Temperature	8 minutes max.

Dimensions (SOIC-08)

<p>Recommended Soldering Pad Layout</p>	Dimension				
	Symbol	Millimeters		Inches	
		Min.	Max.	Min.	Max.
	A	4.80	5.00	0.189	0.197
B	5.80	6.20	0.228	0.244	
C	3.80	4.00	0.150	0.157	
D	1.27		0.050		
E	0.33	0.51	0.013	0.020	
F	0.40	1.27	0.016	0.050	
G	0.19	0.25	0.007	0.010	
H	1.35	1.75	0.053	0.069	
H1	0.10	0.25	0.004	0.010	
H2	1.45		0.057		

Packaging

<p>Tape</p>	Symbol	Dimension (mm)
	W	12.00±0.30
	P0	4.00±0.10
	P1	8.00±0.10
	P2	2.00±0.10
	D0	Φ1.55±0.10
	D1	Φ1.55±0.05
	E	1.75±0.10
	F	5.50±0.10
	A	6.50±0.10
	B	5.40±0.10
	K	2.00±0.10
	t	0.30±0.05
	<p>Reel</p>	D
D2		Φ13.0
W1		13.5
Quantity: 2500PCS		