

A. MAXIMUM RATING:

1. Operating temperature range: -40 °C to +85 °C
2. Storage temperature range: -40 °C to +85 °C
3. Input power : 29dB (Ta=+50 °C,5000h,WCDMA modulation)
4. Maximum DC Voltage: +/-3 V
5. Moisture Sensitivity Level: Level 1 (MSL 1)
6. ESD 100V(MM) 200V(HBM)

RoHS Compliant

Lead-free soldering

Electrostatic Sensitive Device (ESD)

B. ELECTRICAL CHARACTERISTICS:

Terminating impedance (Tx Port): 50+5.1nH Ω(Single-ended)

Terminating impedance (Rx Port): 50 Ω (Differential)

Terminating impedance (Ant Port): 50//8.2nH Ω(Single-ended)

Tx to ANT (f_{T0}=831.5 MHz)

Parameters Description		Unit	Min	Typ	Max	Remarks
Insertion Loss	815 ~ 845MHz	dB(*1)	-	1.3	2.5	
	814.24 ~ 815MHz	dB(*1)		1.4	2.6	
	845 ~ 848.76MHz	dB(*1)		1.9	3.2	
Amplitude ripple	814.24 ~ 848.76MHz	dB	-	1.2	2.2	
VSWR	Tx	814.24 ~ 848.76MHz	-	-	1.6	2.0
	ANT	814.24 ~ 848.76MHz	-	-	1.5	2.0
Attenuation:						
10 ~ 494 MHz		dB	35	41	-	
494 ~ 804 MHz		dB	18	37	-	
859.24 ~ 893.76 MHz		dB	42	56	-	
1475.9 ~ 1698 MHz		dB	35	40	-	
1710 ~ 2494 MHz		dB	30	35	-	
3256 ~ 4245 MHz		dB	20	27	-	
4884 ~ 6000 MHz		dB	35	44	-	
6512 ~ 6792 MHz		dB	15	28	-	
7326 ~ 7641 MHz		dB	12	26	-	

(*1) Specification of insertion loss excludes loss that comes from the test board

ANT to Rx ($f_{T0}=876.5$ MHz)

Parameters Description		Unit	Min	Typ	Max	Remarks
Insertion Loss	859.24 ~ 893.76 MHz	dB(*1)	-	2.0	3.8	
Amplitude ripple	859.24 ~ 893.76 MHz	dB	-	1.0	3.2	
VSWR	ANT	-		1.8	2.2	
	Rx			1.8	2.5	
Attenuation:						
1 ~ 447 MHz		dB	50	75	-	
814.24 ~ 848.76 MHz		dB	45	55	-	
909 ~ 979 MHz		dB	10	22	-	
1427 ~ 2500 MHz		dB	45	50	-	
2577 ~ 6000 MHz		dB	38	47	-	
6013 ~ 6258 MHz		dB	20	44	-	

Tx to Rx

Isolation	814.24 ~ 848.76 MHz	dB	52	60	-	
	859.24 ~ 893.76 MHz	dB	50	57	-	

(*1) Specification of insertion loss excludes loss that comes from the test board.

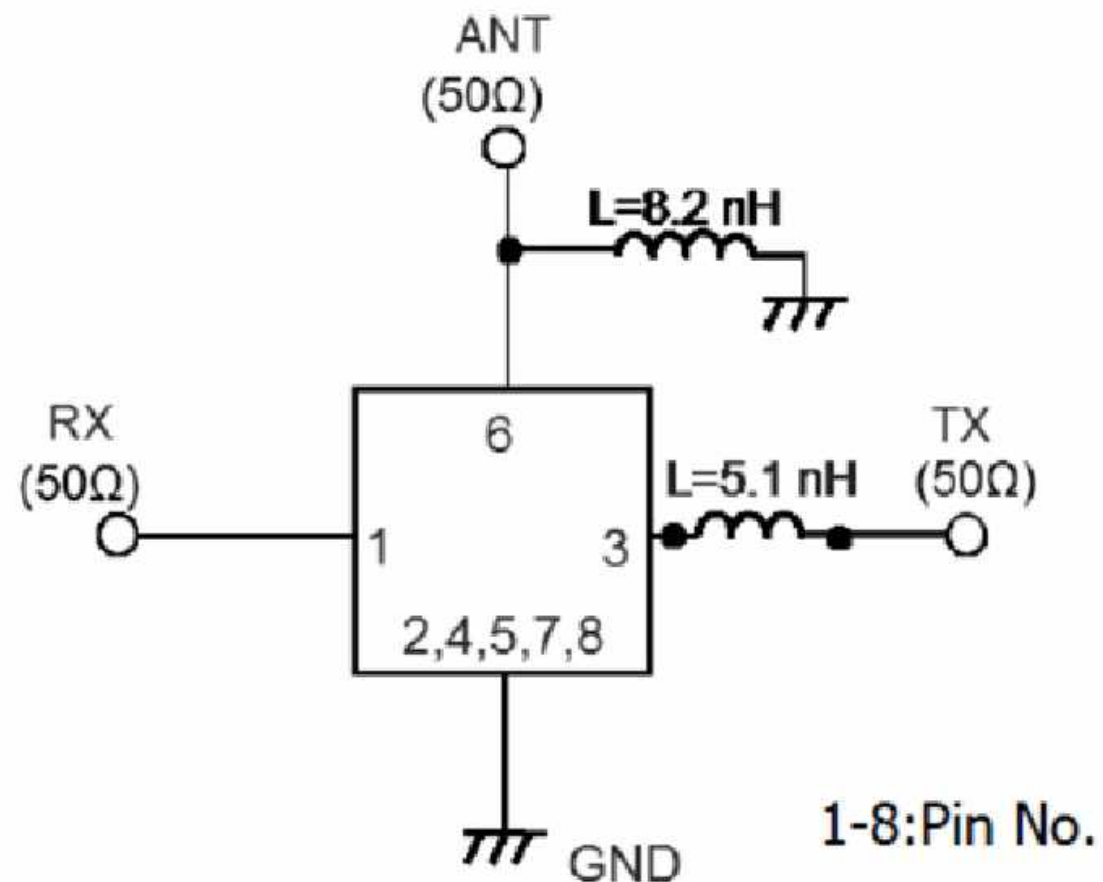
C.Evaluation Circuit

D. FREQUENCY CHARACTERISTICS:

Tx to Ant



Ant to Rx

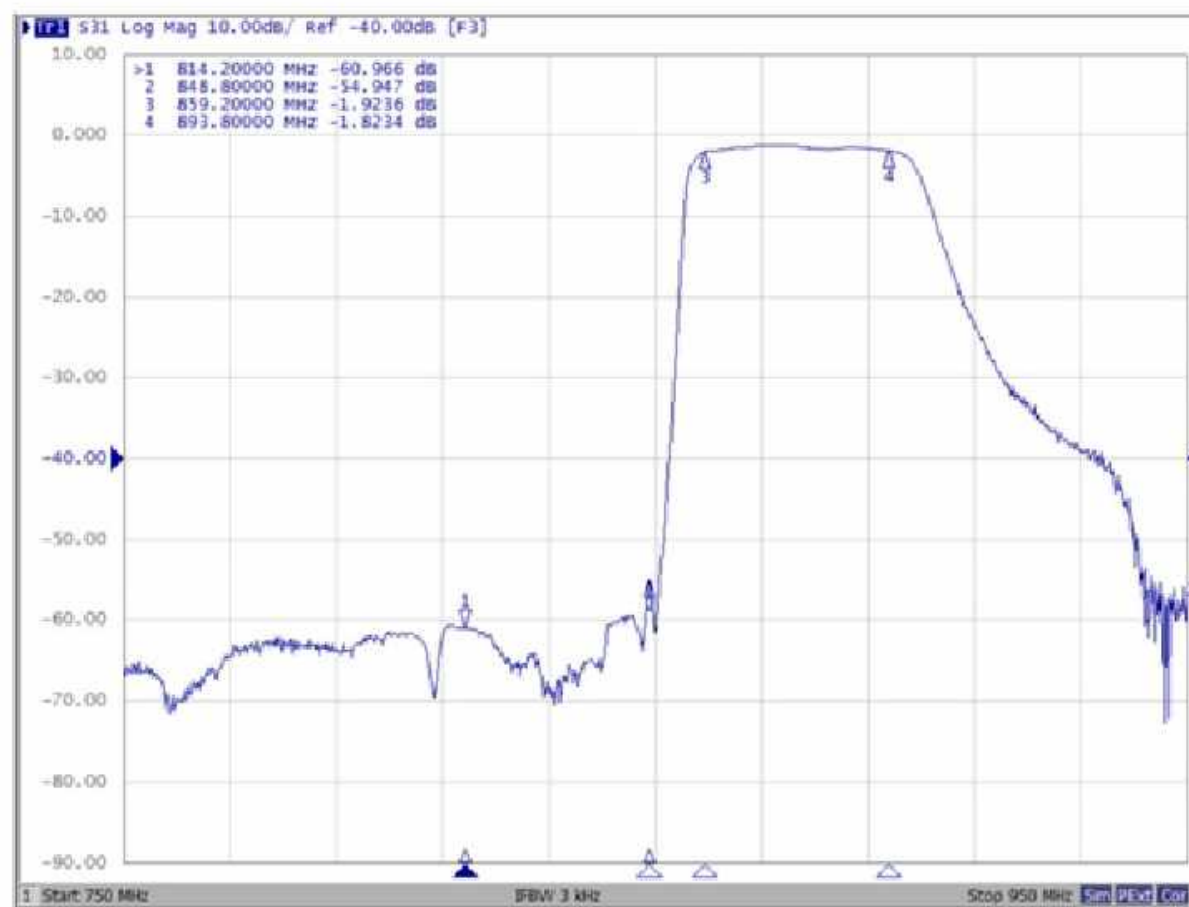

Tx to Ant, Ant to Rx

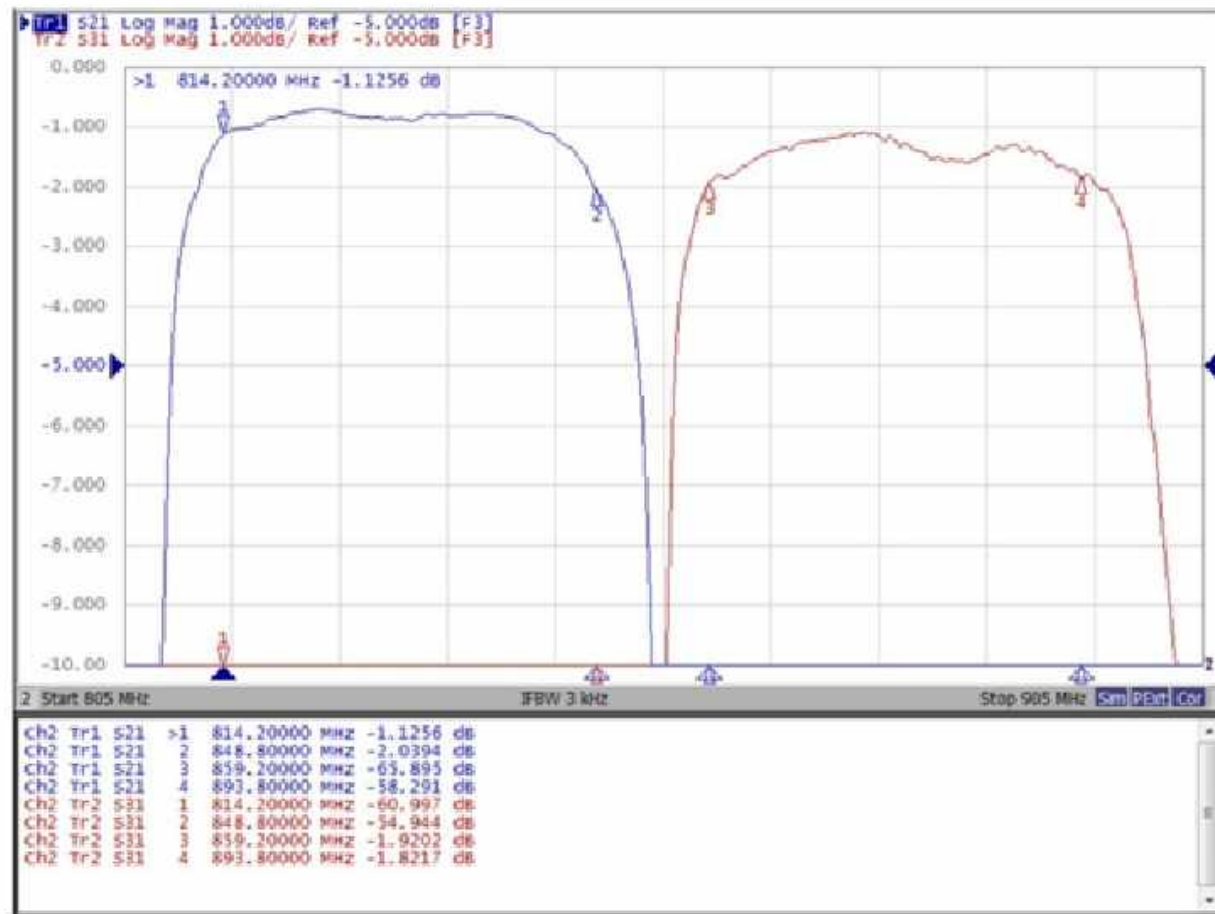

Tx to Rx Isolation

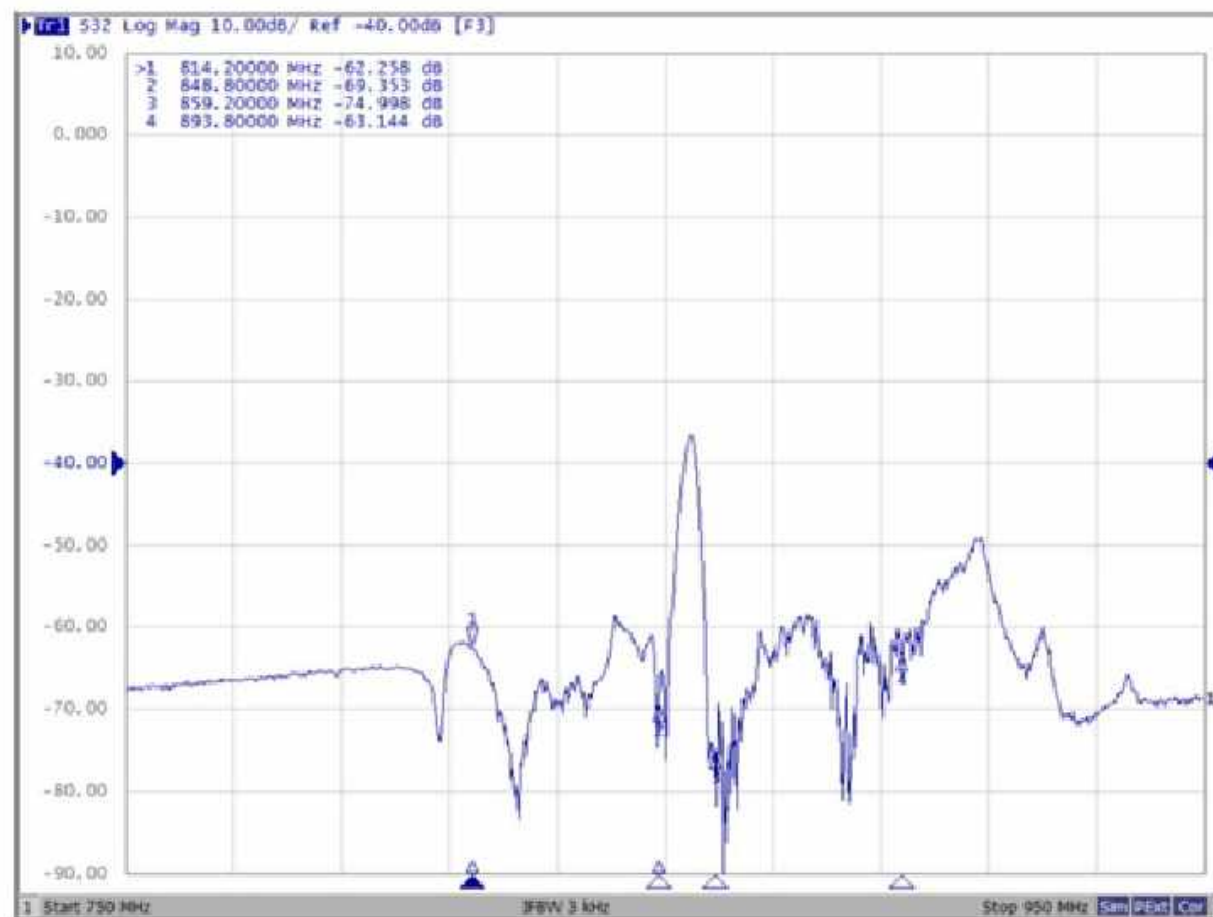

Tx Port

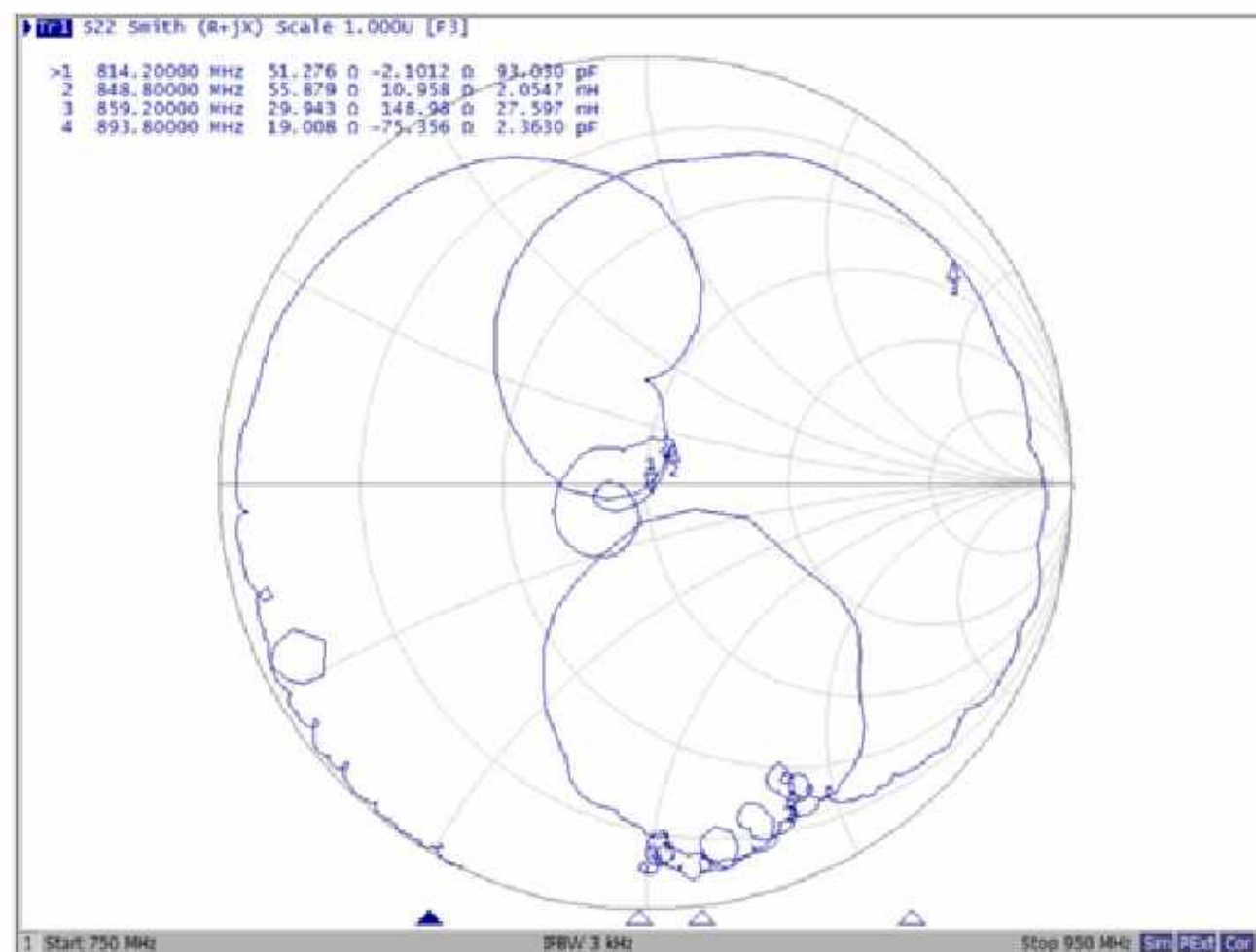
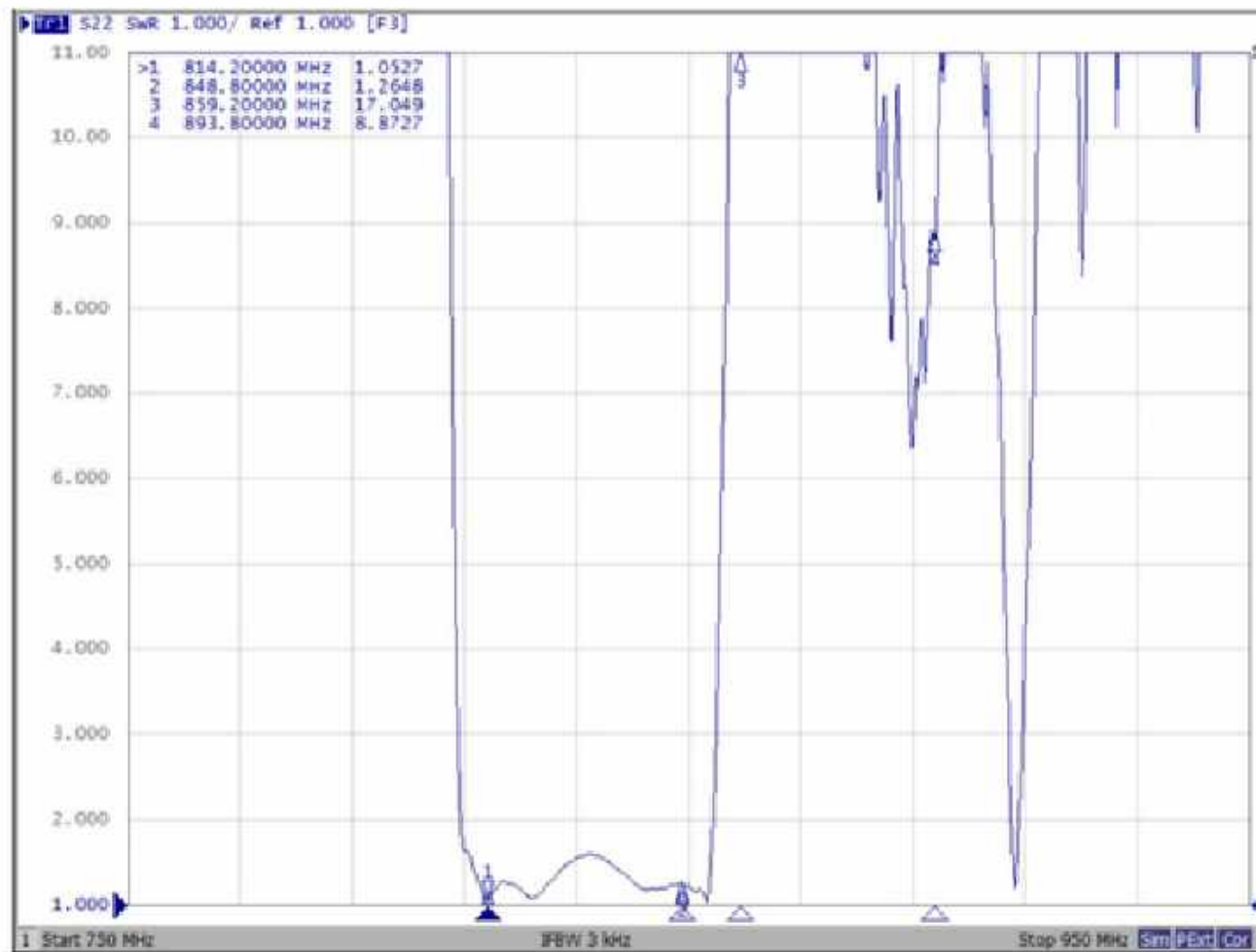

Rx Port

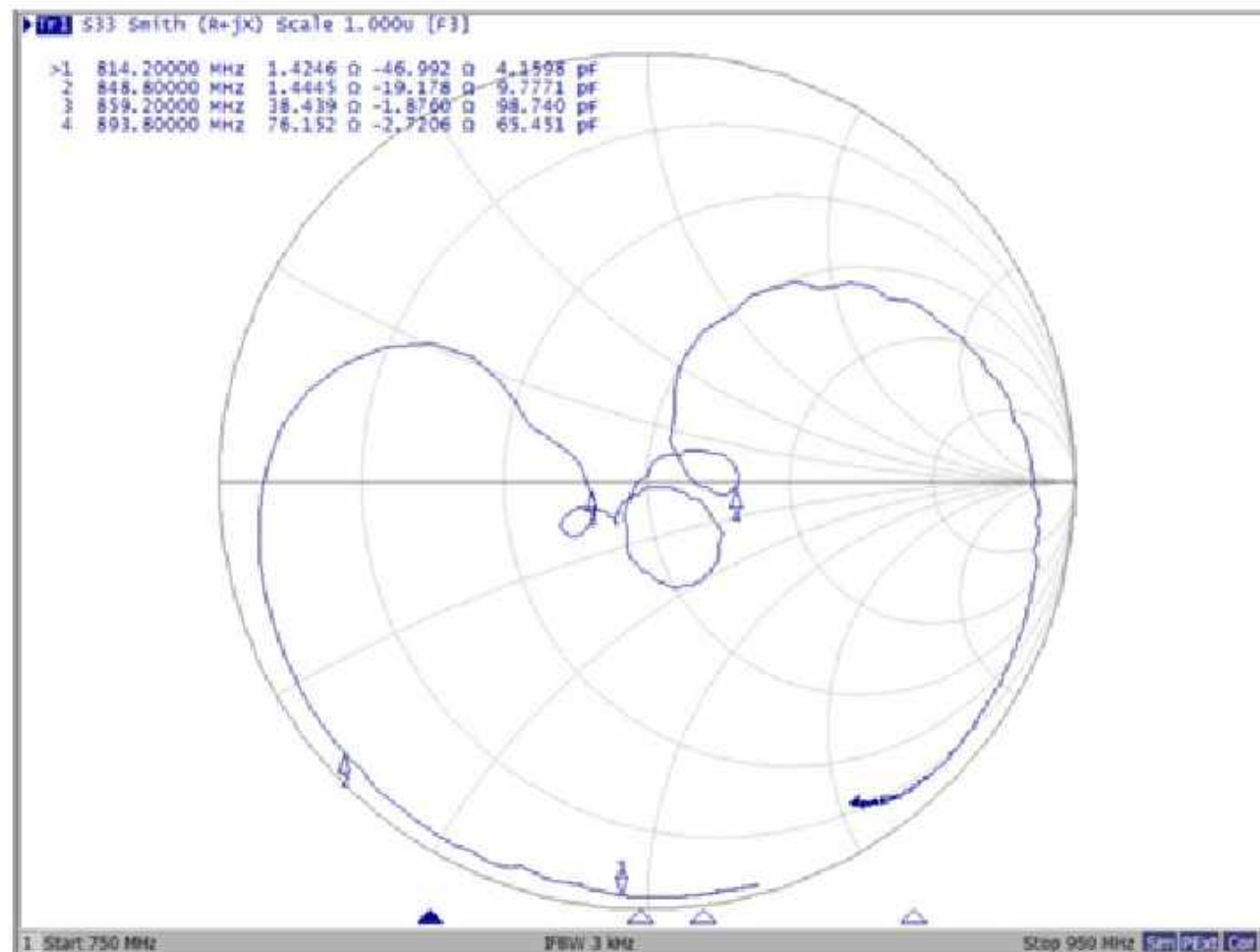
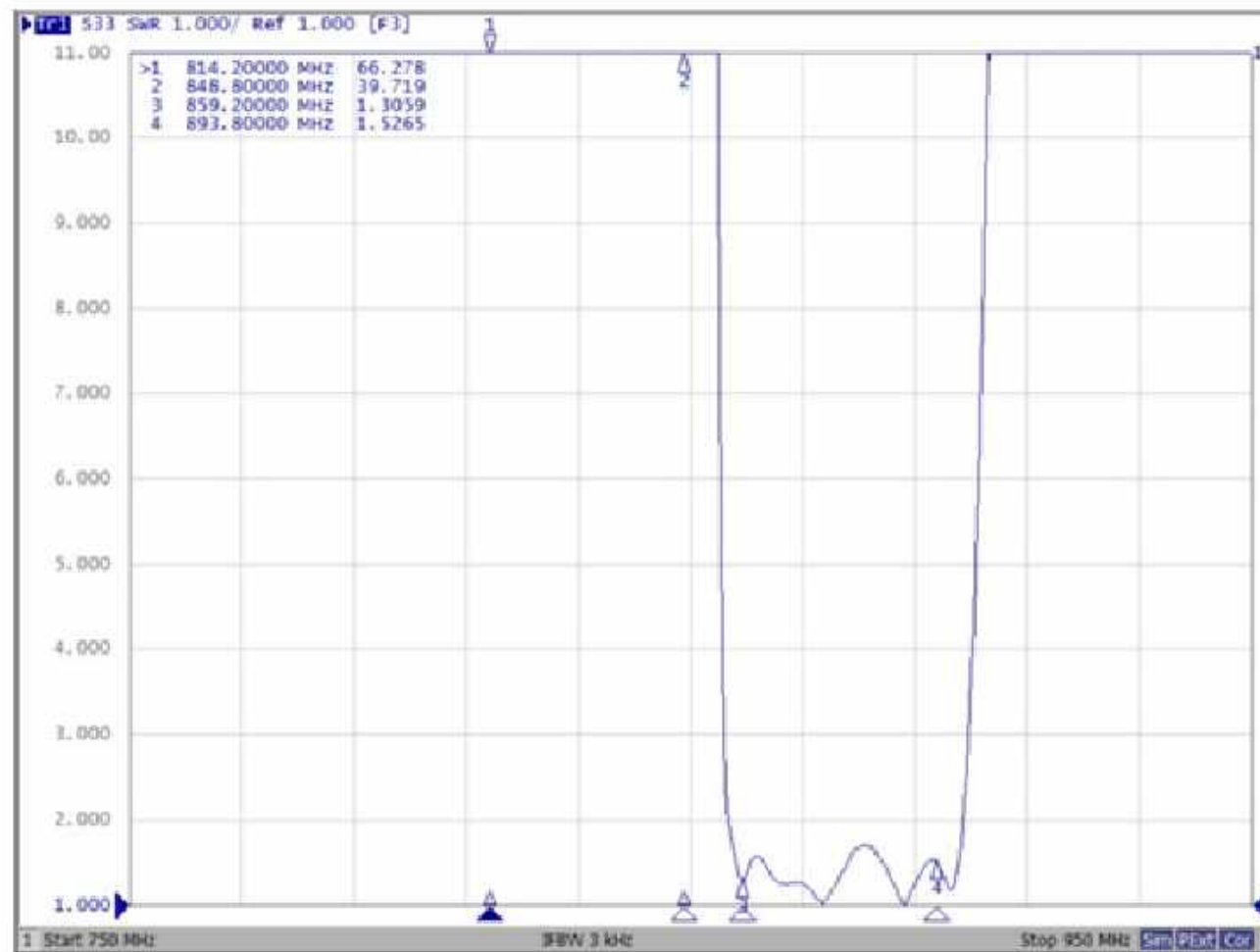

Ant Port

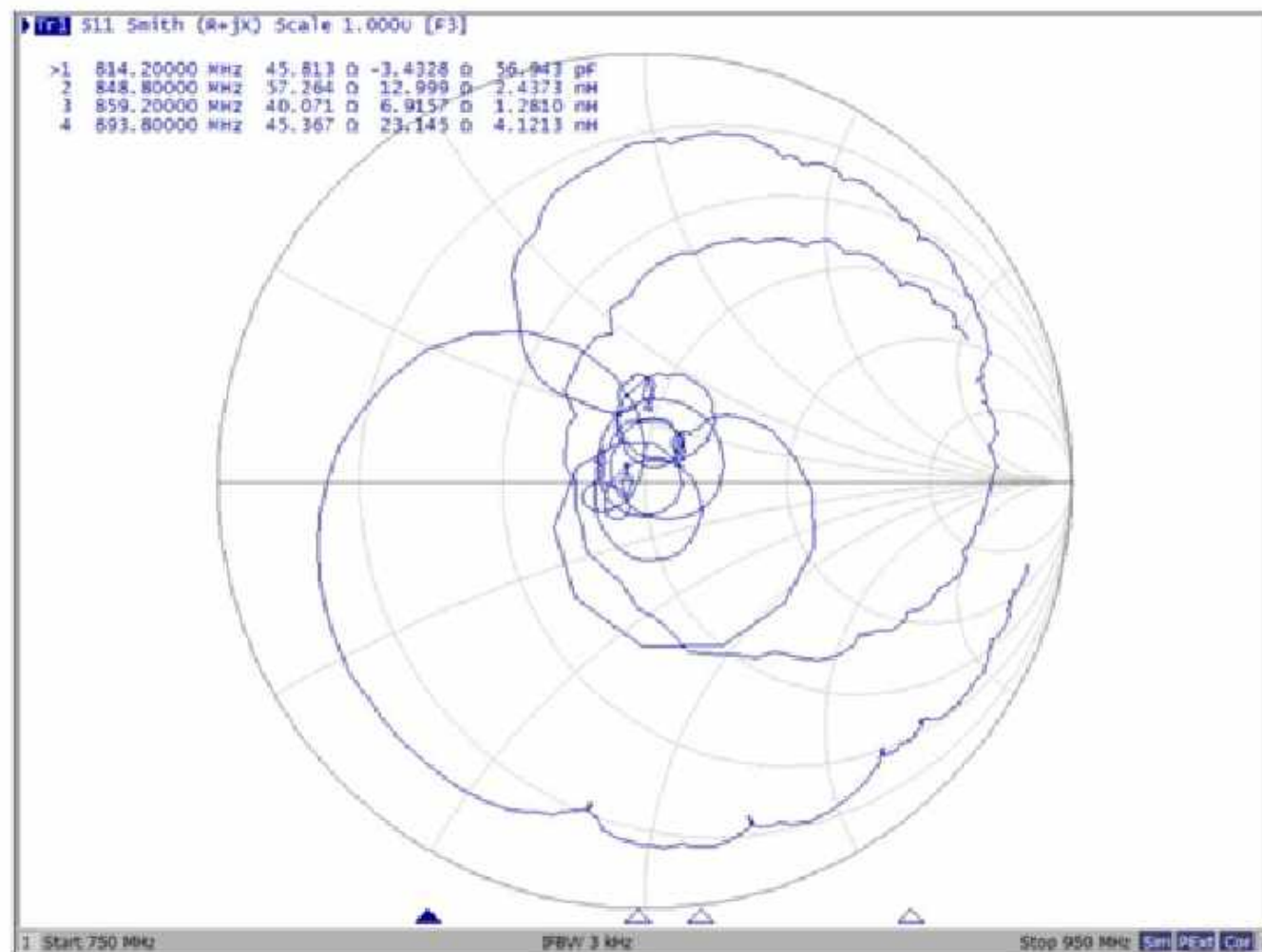
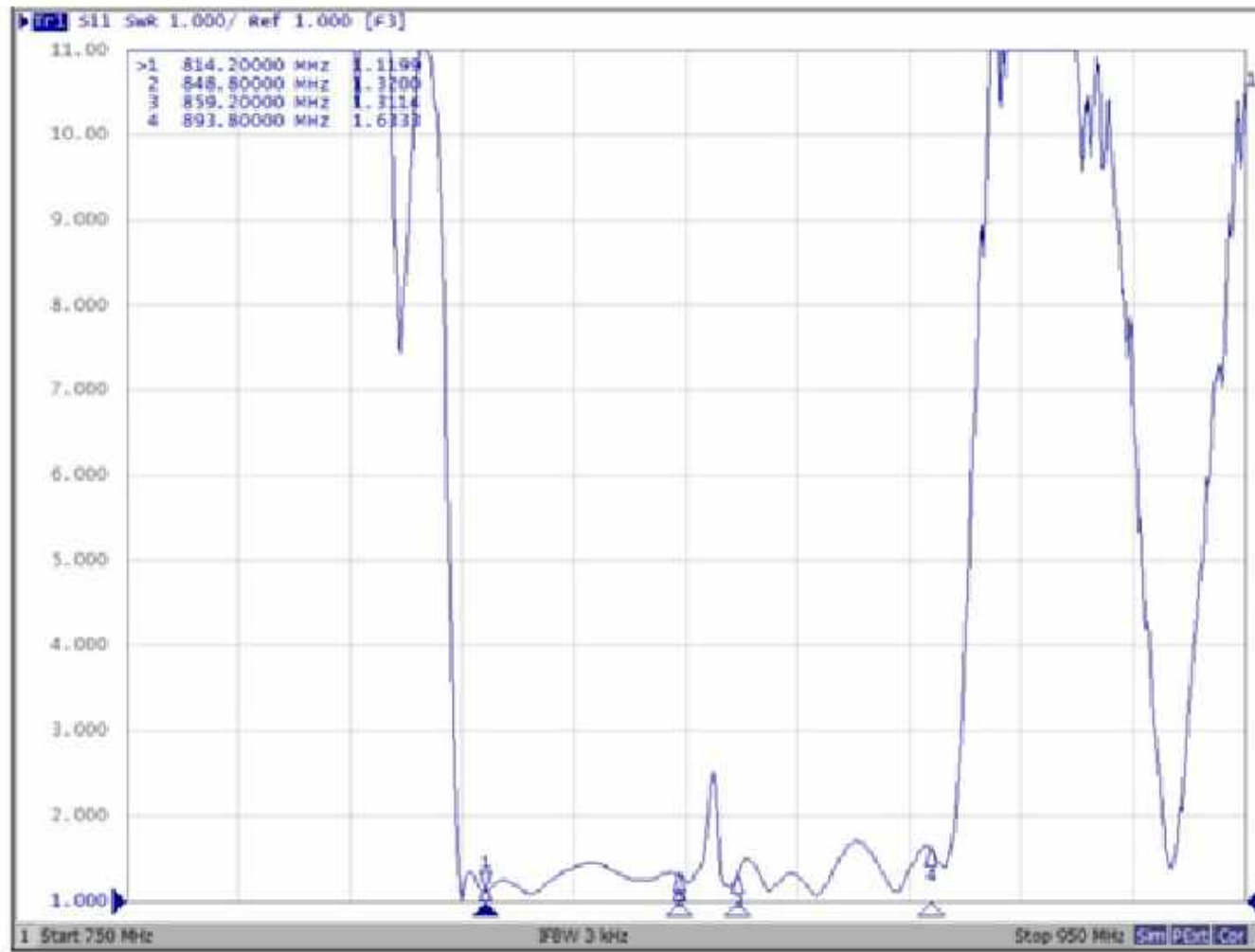

Tx to Ant (Wide Span)

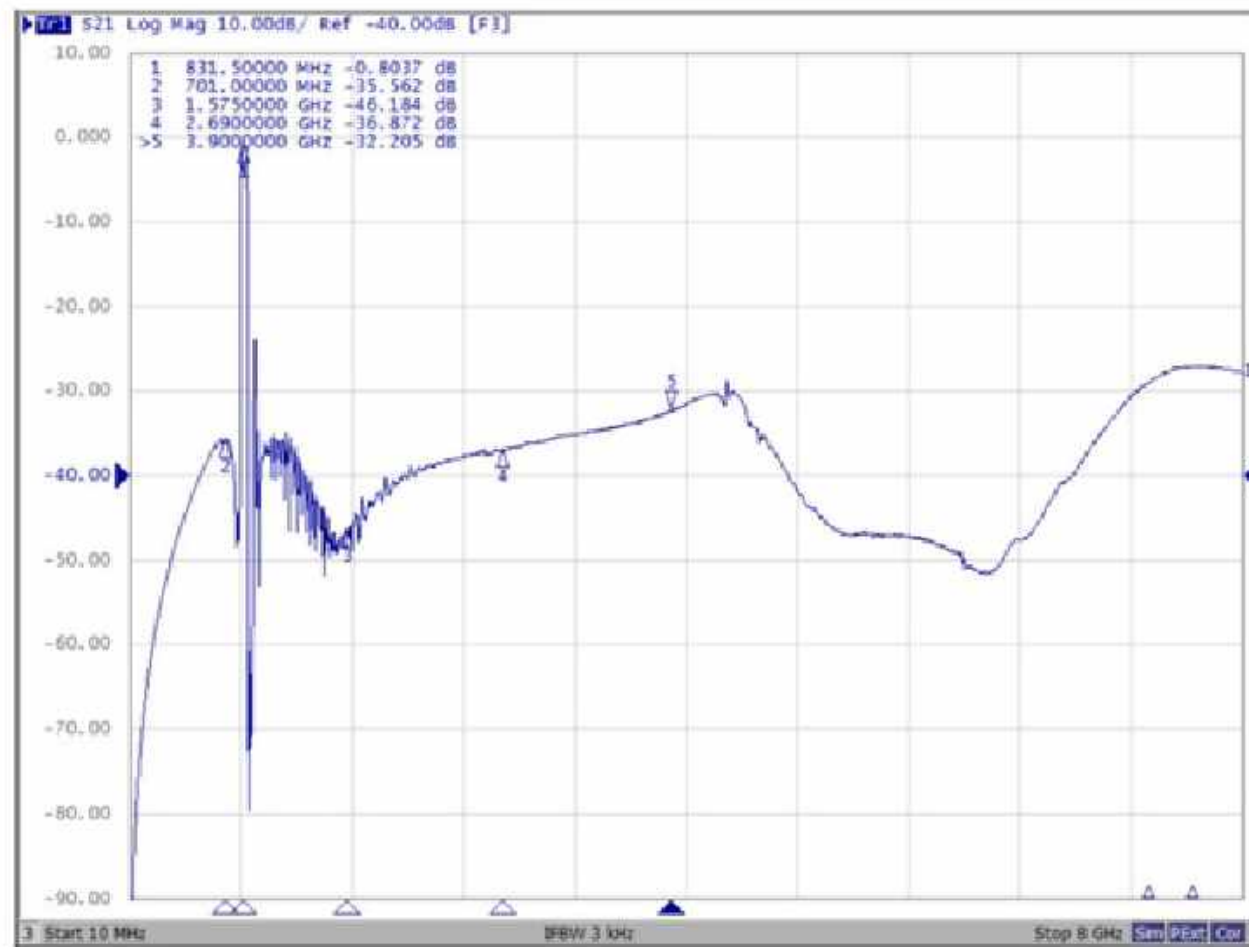

Ant to Rx (Wide Span)



**E.OUTLINE DRAWIN:
(Mass Production)**

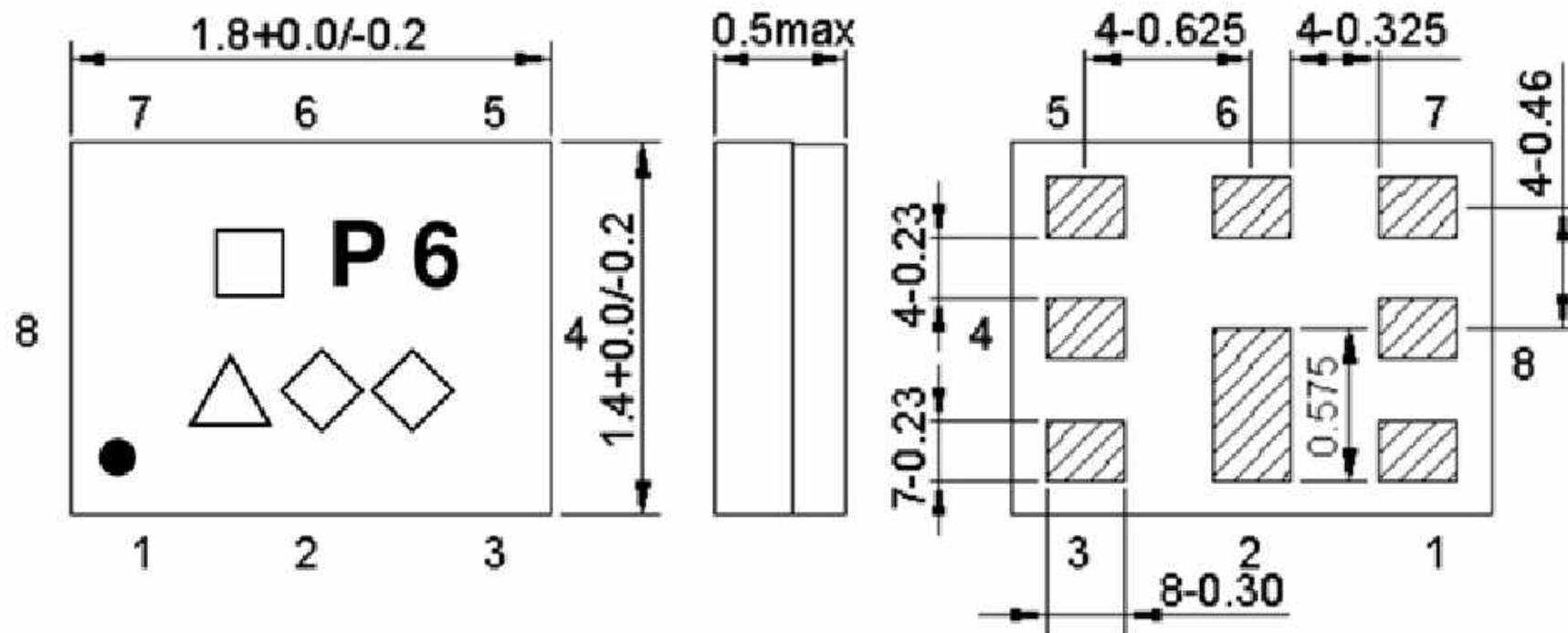

Traceability code (□ : S or 7)

△: Date code(2016 May → s ,....., 2019 Dec→m.)

◇◇: Lot Code.

Product Date Code. Follow below table. (4-year cycle)

Year	Jan	Feb	Mar	Apr	May	Jun	Jul	Aug	Sep	Oct	Nov	Dec
2016 / 2020	n	p	q	r	s	t	u	v	w	x	y	z
2017 / 2021	A	B	C	D	E	F	G	H	J	K	L	M
2018 / 2022	N	P	Q	R	S	T	U	V	W	X	Y	Z
2019 / 2023	a	b	c	d	e	f	g	h	j	k	l	m



Pin assignment

Pin No.	Pin name	Description
1	Rx	Receiver
2	GND	Ground
3	Tx	Transmitter
4	GND	Ground
5	GND	Ground
6	Ant	Antenna
7	GND	Ground
8	GND	Ground

Figure 1. Dimensions and Pin assignment

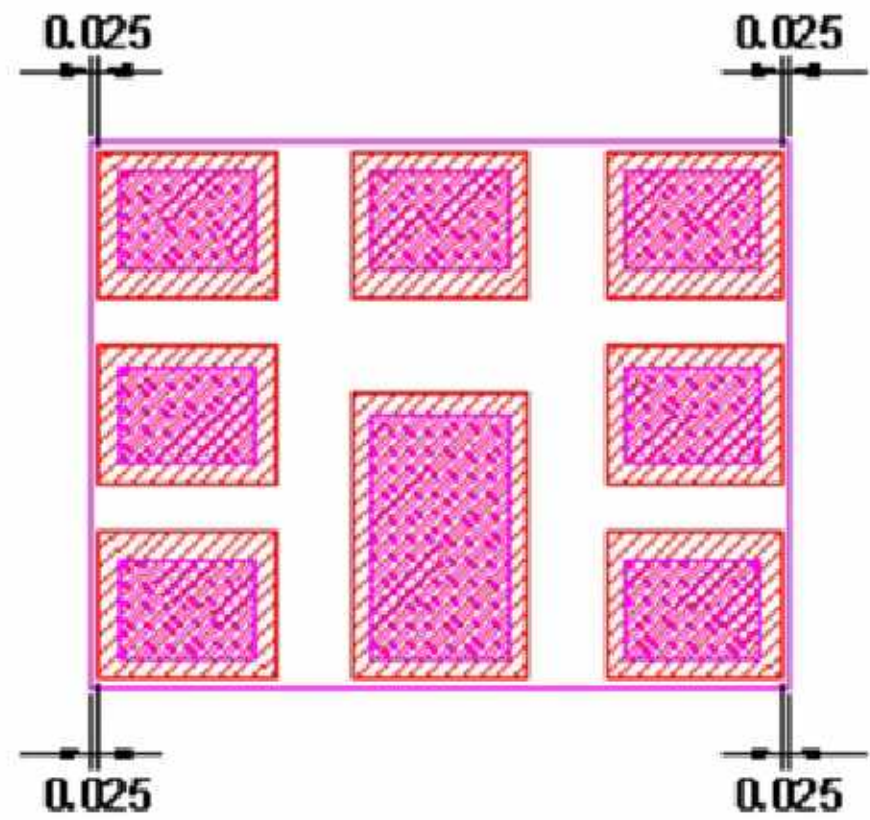
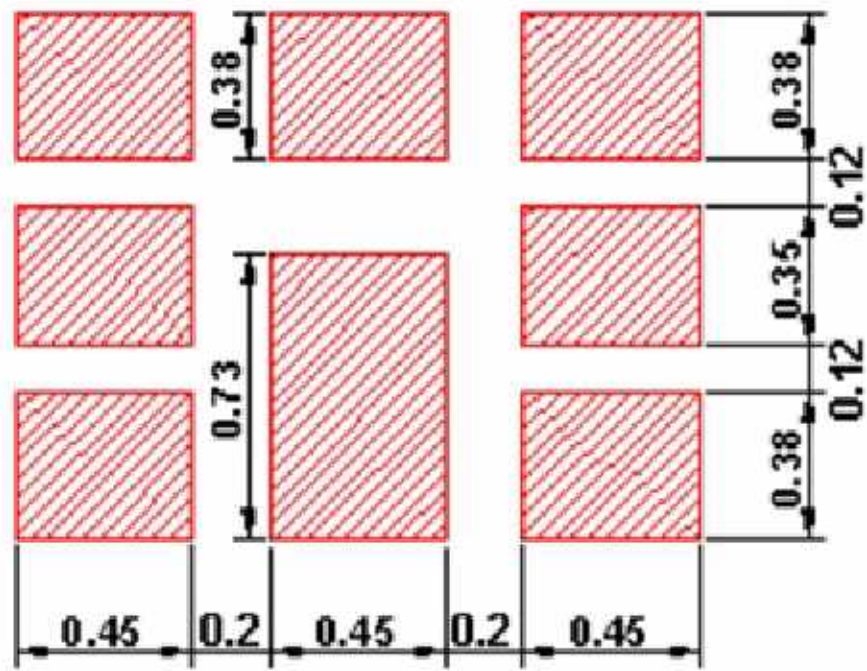
E . FOOTPRINT:



- : Pad pattern
- : Resist pattern

G. PACKING:

1. REEL DIMENSION

(Please refer to FR-75D10 for packing quantity)

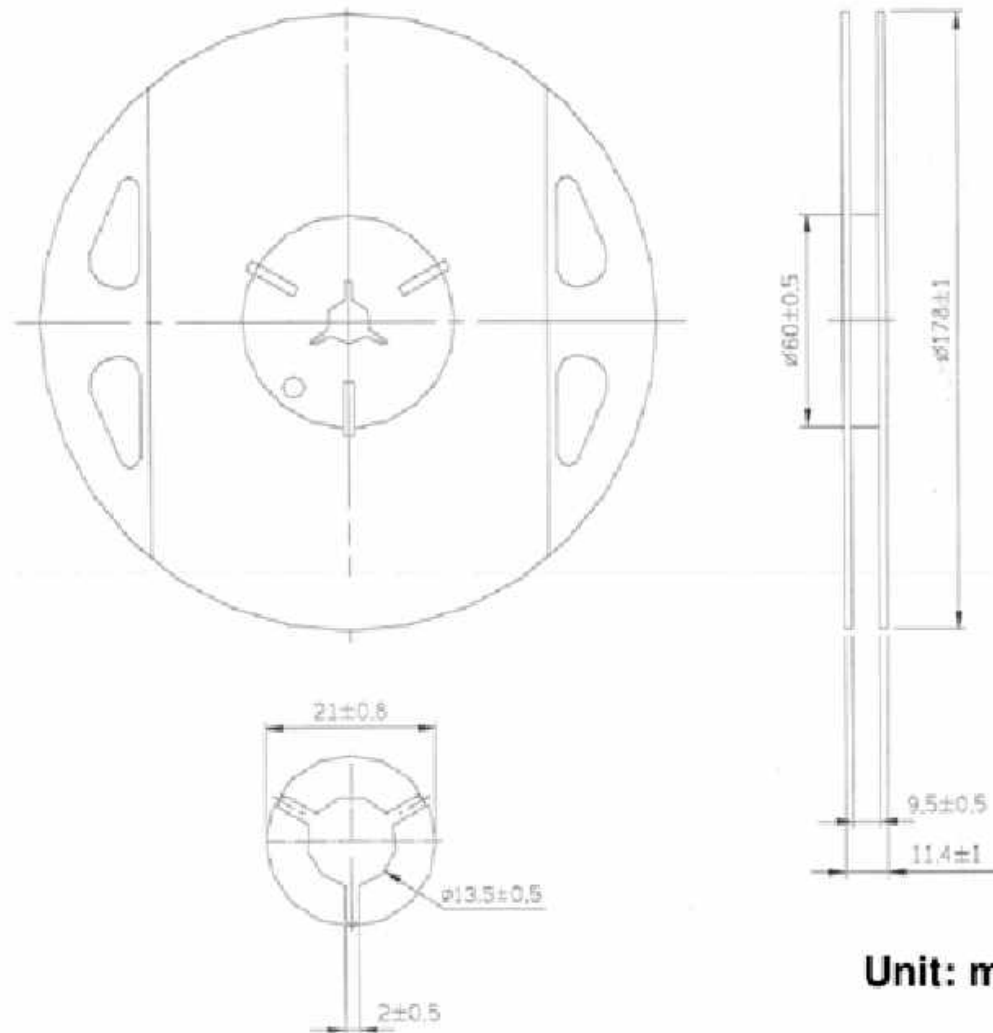

Unit: mm

2. TAPE DIMENSION

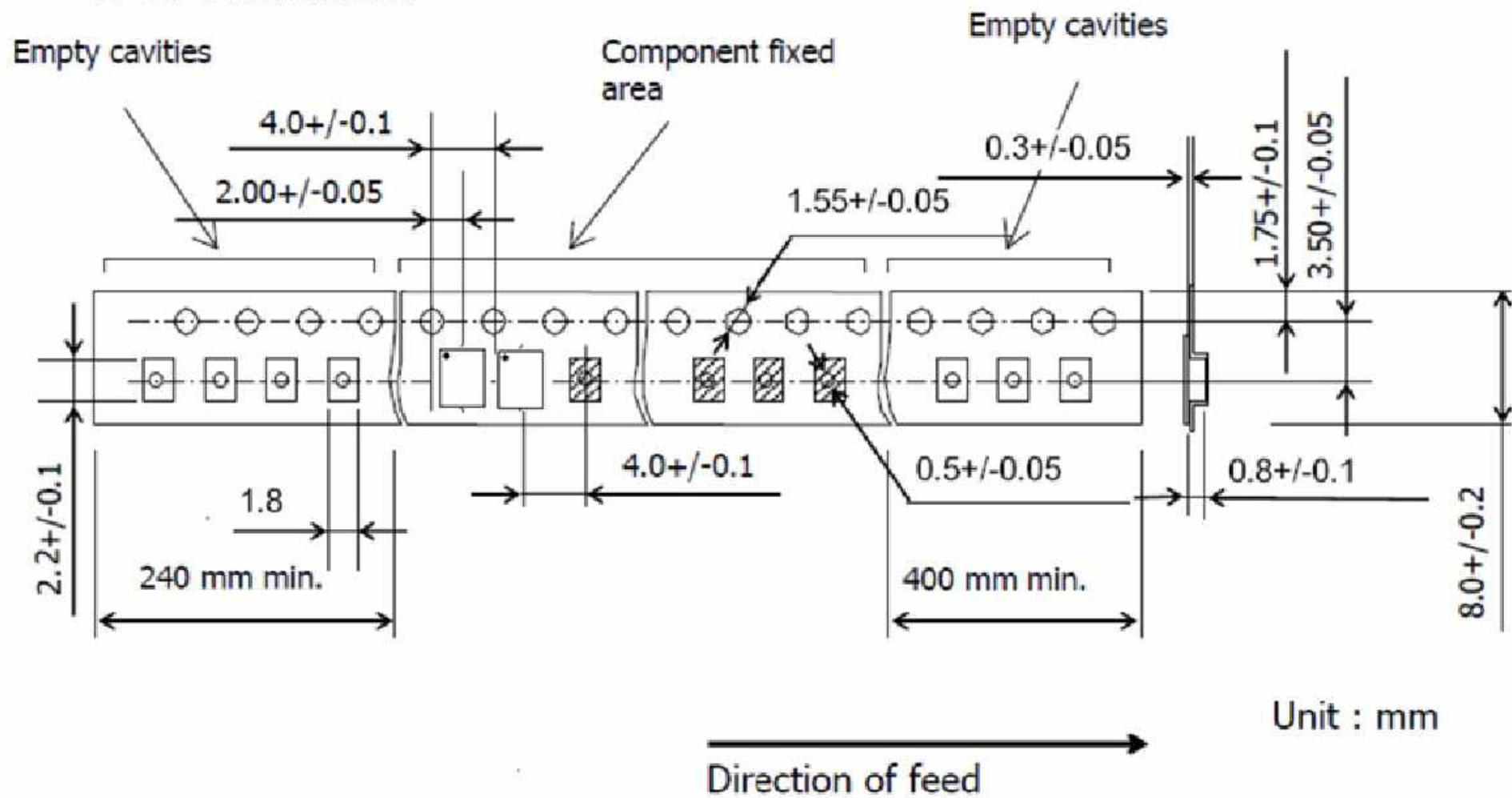

Unit : mm

H. RECOMMENDED REFLOW PROFILE :

1. Preheating shall be fixed at 150~180°C for 60~90 seconds.
2. Ascending time to preheating temperature 150°C shall be 30 seconds min.
3. Heating shall be fixed at 220°C for 50~80 seconds and at 245~260°C peak (min. 10sec).
4. Time : 2 times.

