

SAW DPX 897.5/942.5 MHz

MODEL NO.:TF0094A

REV. NO.:3.0

A. MAXIMUM RATING:

1. Input Power Level at Tx port: 29 dBm (10000 hours)
2. DC Voltage Tx & Rx port: +/-5 V
3. DC Voltage Ant port: 0 V
4. Operating Temperature: -20 °C to +85 °C
5. Storage Temperature: -40 °C to +85 °C
6. Moisture Sensitive Level: Level 1 (MSL1)
7. ESD: 100 V(MM), 200 V(HBM)

RoHS Compliant
Lead-free soldering

Electrostatic Sensitive Device (ESD)

B. ELECTRICAL CHARACTERISTICS:

Terminating impedance (Tx port): 50 Ω

Terminating impedance (Rx port): 100 Ω (Balanced)

Terminating impedance (Ant port): 50//7.5nH Ω

Tx to Ant

Item	Unit	Min.	Typ.	Max.
Insertion Loss (882.4~912.6 MHz)	dB(*1)	-	1.8	2.6(*2)
Amplitude Ripple (882.4~912.6 MHz)	dB	-	0.8	1.9
VSWR Tx (880.4~914.6 MHz)	-	-	1.9	2.2
VSWR Ant (880.4~914.6 MHz)	-	-	1.7	2.0
Attenuation (Reference level from 0 dB)				
10 ~ 821 MHz	dB	33	38	-
927.4 ~ 957.6 MHz	dB	44(*2)	53	-
1565.4 ~ 1605.9 MHz	dB	45	50	-
1760 ~ 1880 MHz	dB	40	49	-
1880 ~ 2500 MHz	dB	33	39	-
2620 ~ 2745 MHz	dB	30	36	-
3520 ~ 3660 MHz	dB	20	31	-
4400 ~ 4575 MHz	dB	15	24	-
5150 ~ 5850 MHz	dB	10	25	-

Ant to Rx

Item	Unit	Min.	Typ.	Max.
Insertion Loss (927.4~957.6 MHz)	dB(*1)	-	2.2	2.6(*2)
Insertion Loss (925~960 MHz)	dB(*1)	-	2.3	3.3
Amplitude Ripple (925~960 MHz)	dB	-	0.8	2.2
Amplitude Balance (925~960 MHz)	dB	-0.7	-0.3/+0.2	+0.7
Phase Balance (925~960 MHz)	deg	-7	-2/+3	+7
VSWR Ant (925~960 MHz)	-	-	1.8	2.1
VSWR Rx (925~960 MHz)	-	-	2.0	2.3
Attenuation (Reference level from 0 dB)				
10 ~ 880 MHz	dB	35	58	-
882.4 ~ 912.6 MHz	dB	48(*2)	58	-
1045 ~ 4810 MHz	dB	35	48	-

Tx to Rx

Item	Unit	Min.	Typ.	Max.
Isolation (Reference level from 0 dB)	882.4 ~ 912.6 MHz	dB	56(*2)	60
	927.4 ~ 957.6 MHz	dB	50(*2)	55

(*1) Specification of insertion loss excludes loss that comes from the test board. (Approximately 0.05 dB)

(*2) Integrated over +/-1.92 MHz around the WCDMA channel center frequency.

C. MEASUREMENT CIRCUIT:

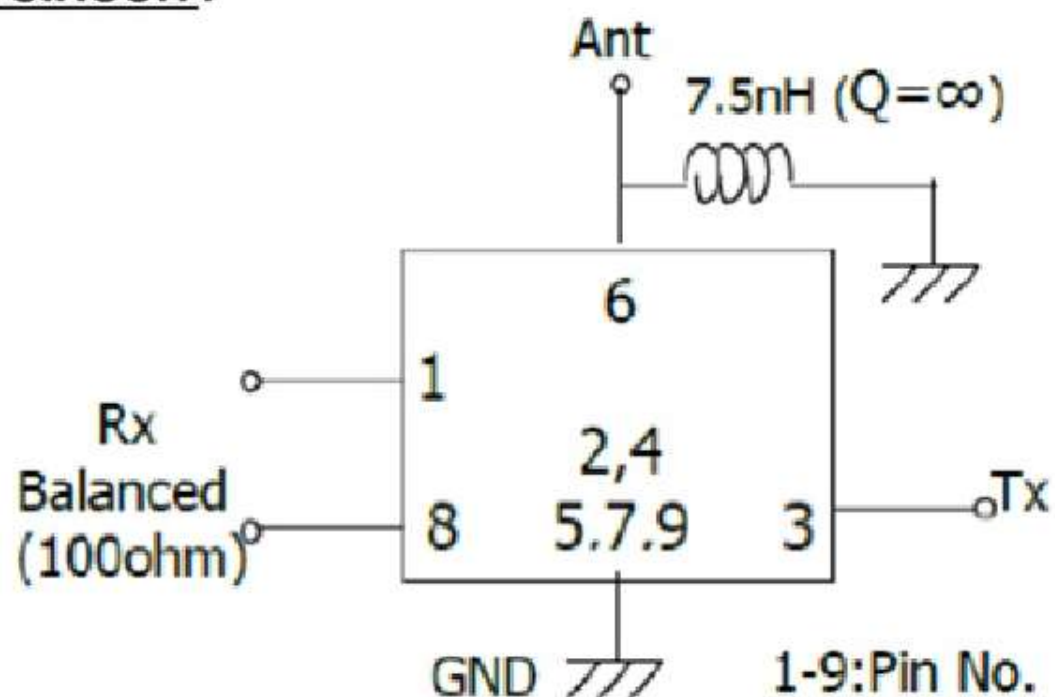

D. FREQUENCY CHARACTERISTICS:

Tx to Ant

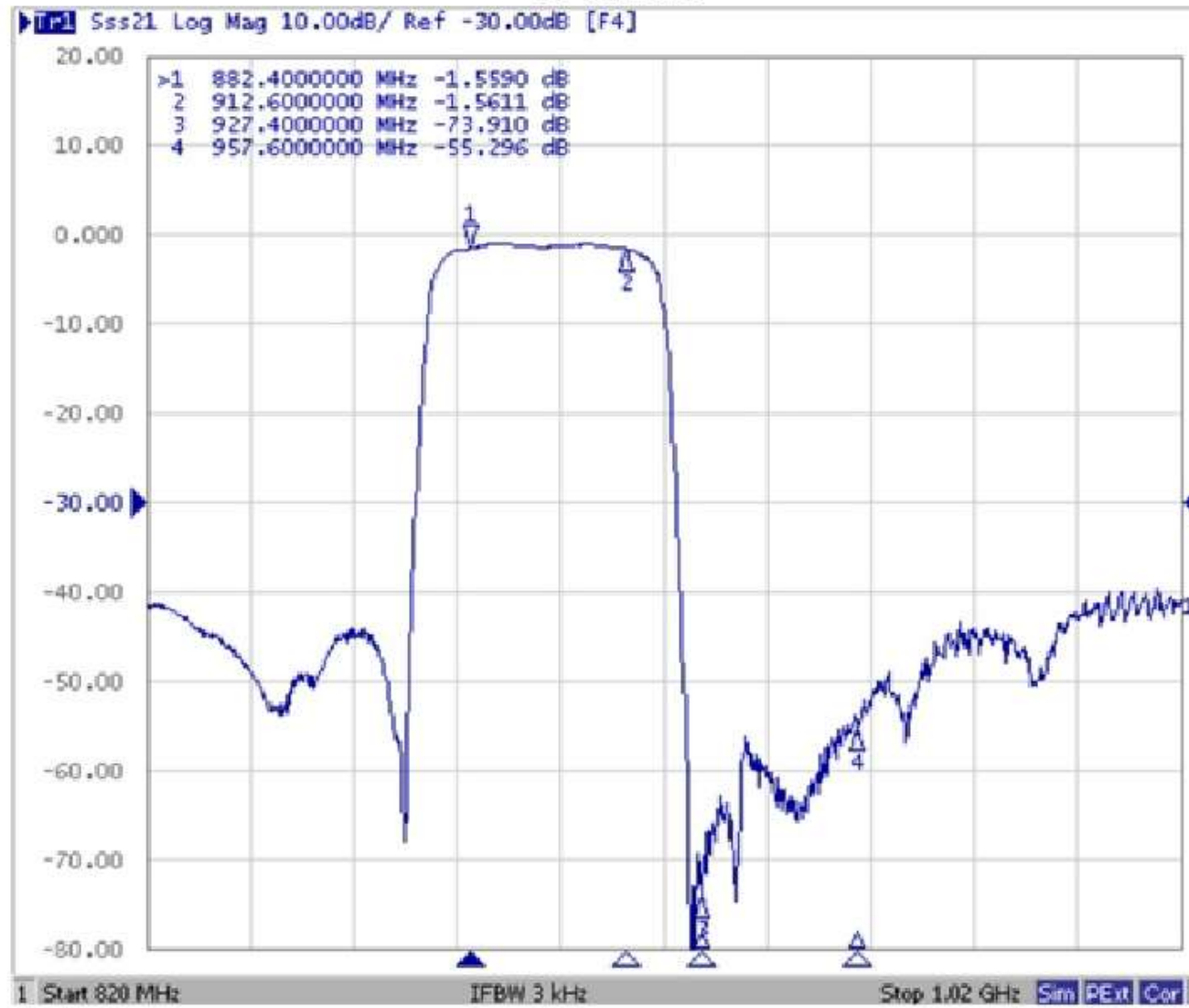

Ant to Rx

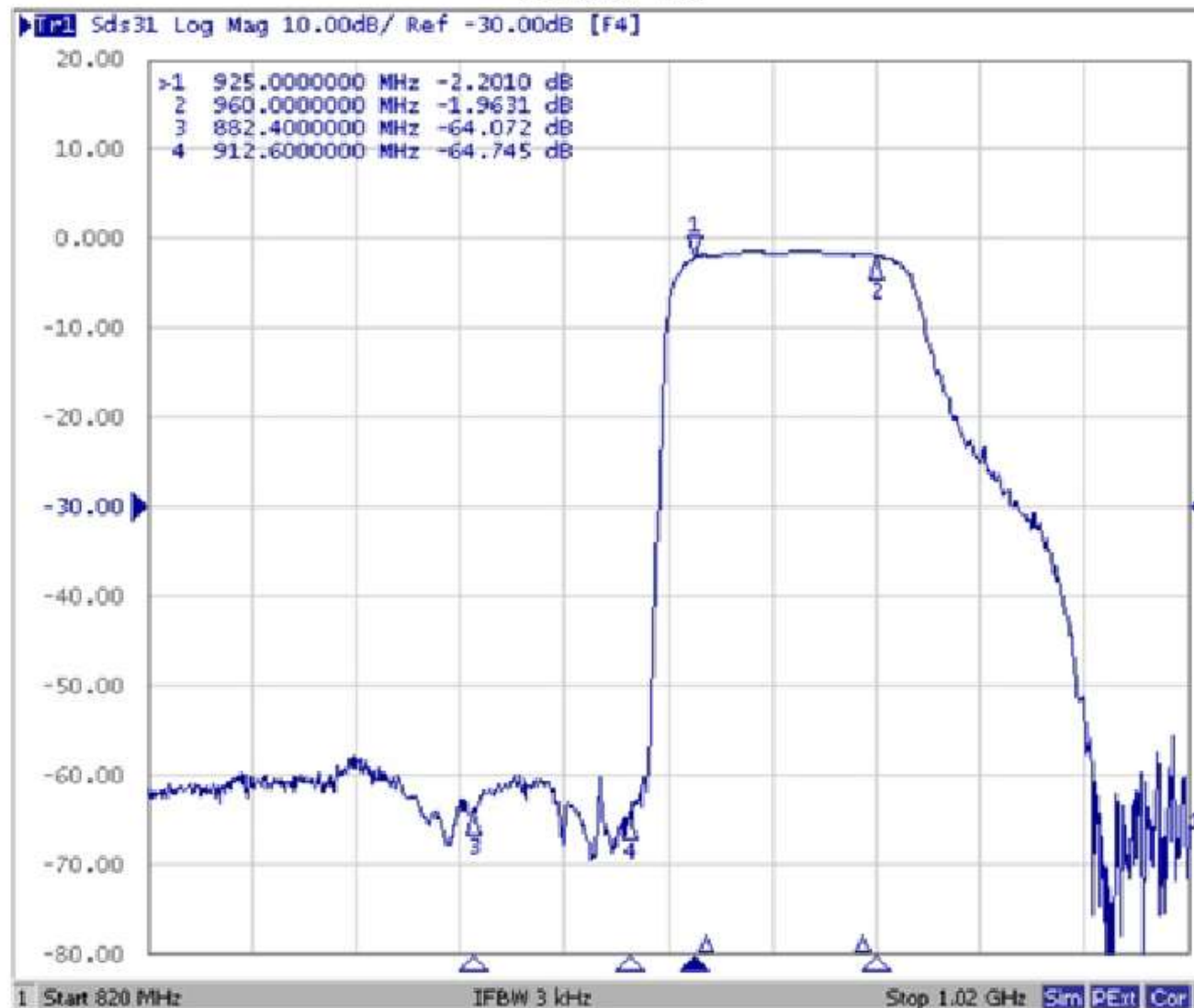

Tx to Ant, Ant to Rx

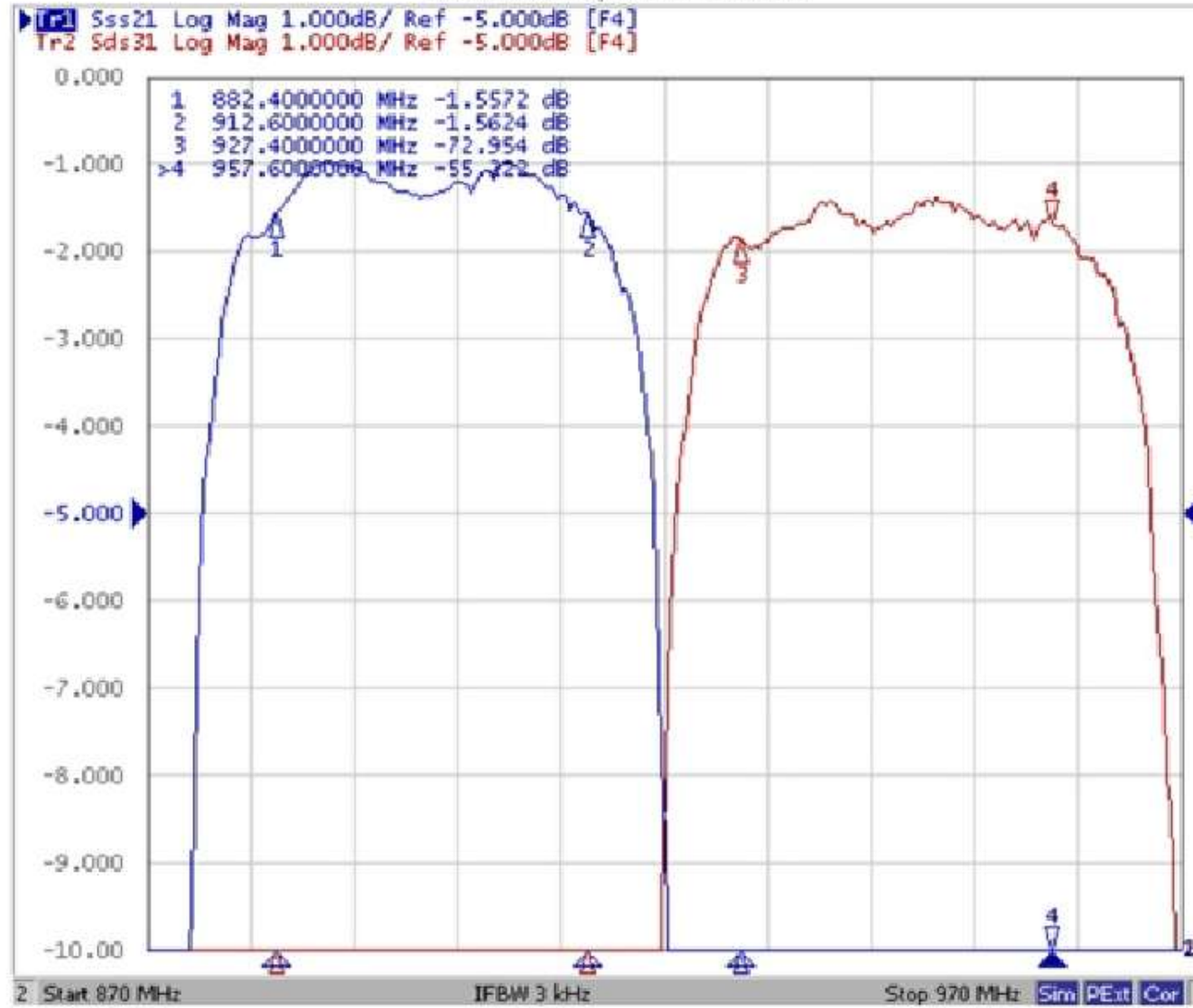

Tx to Rx Isolation

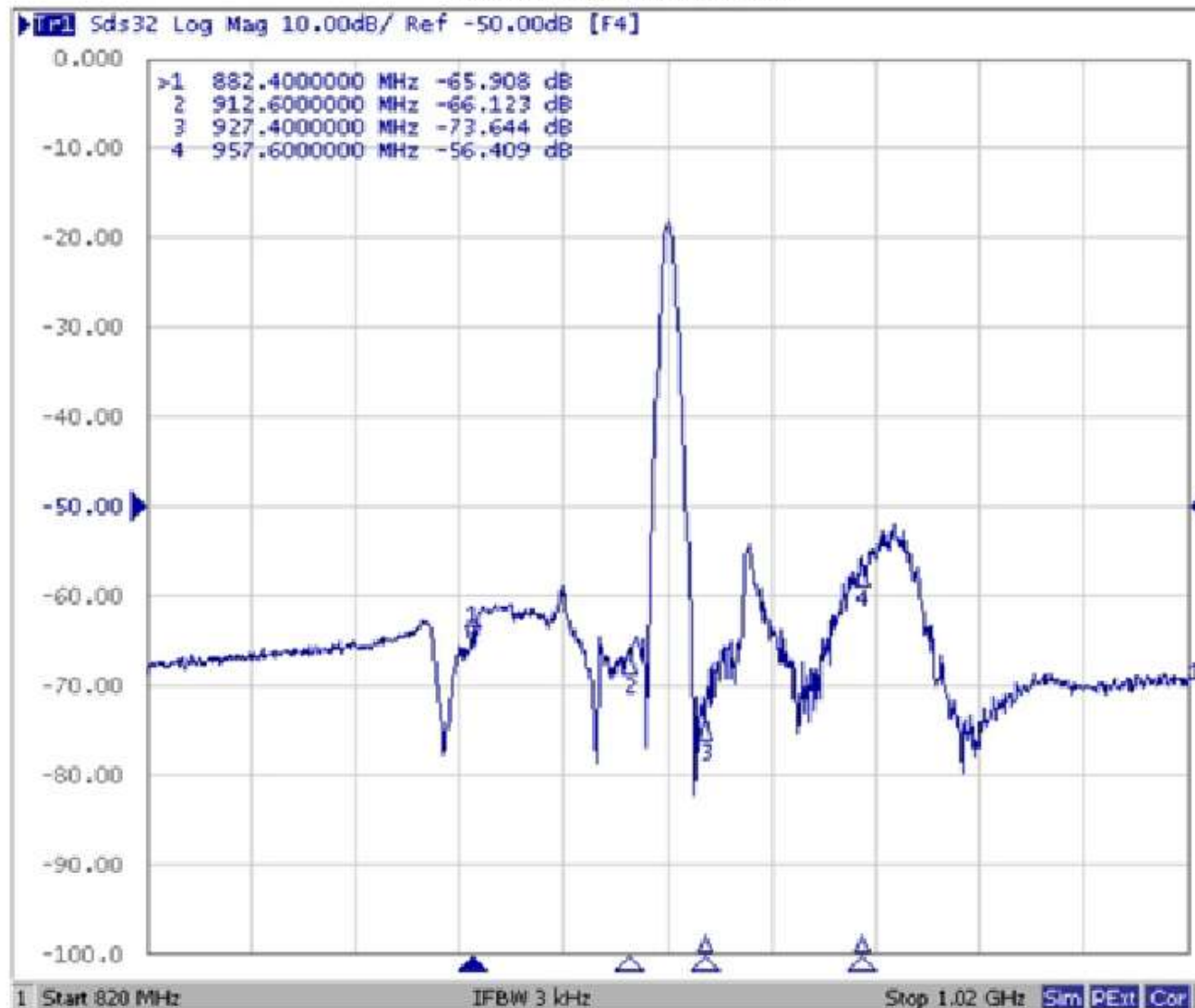

Tx Port

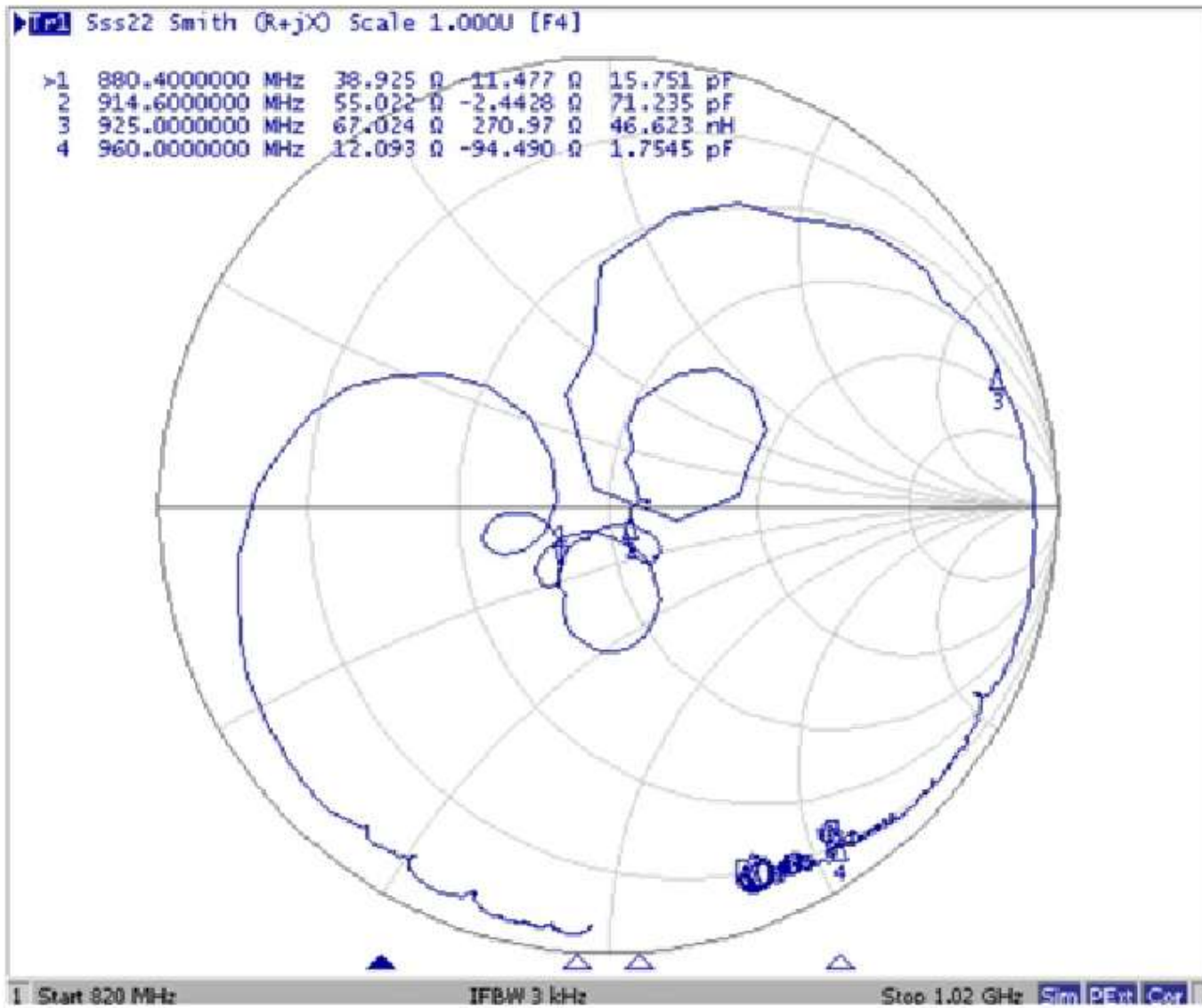
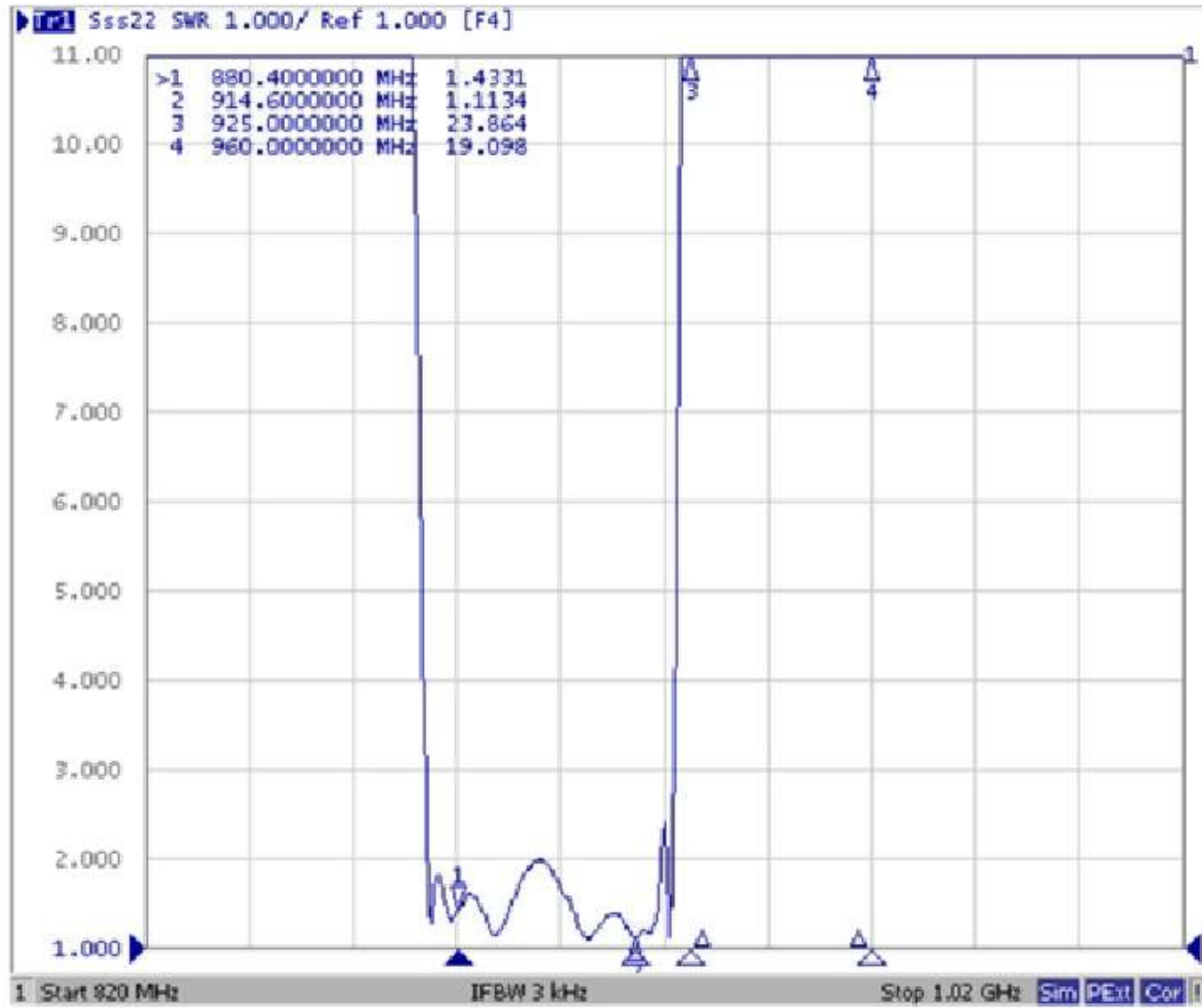

Rx Port

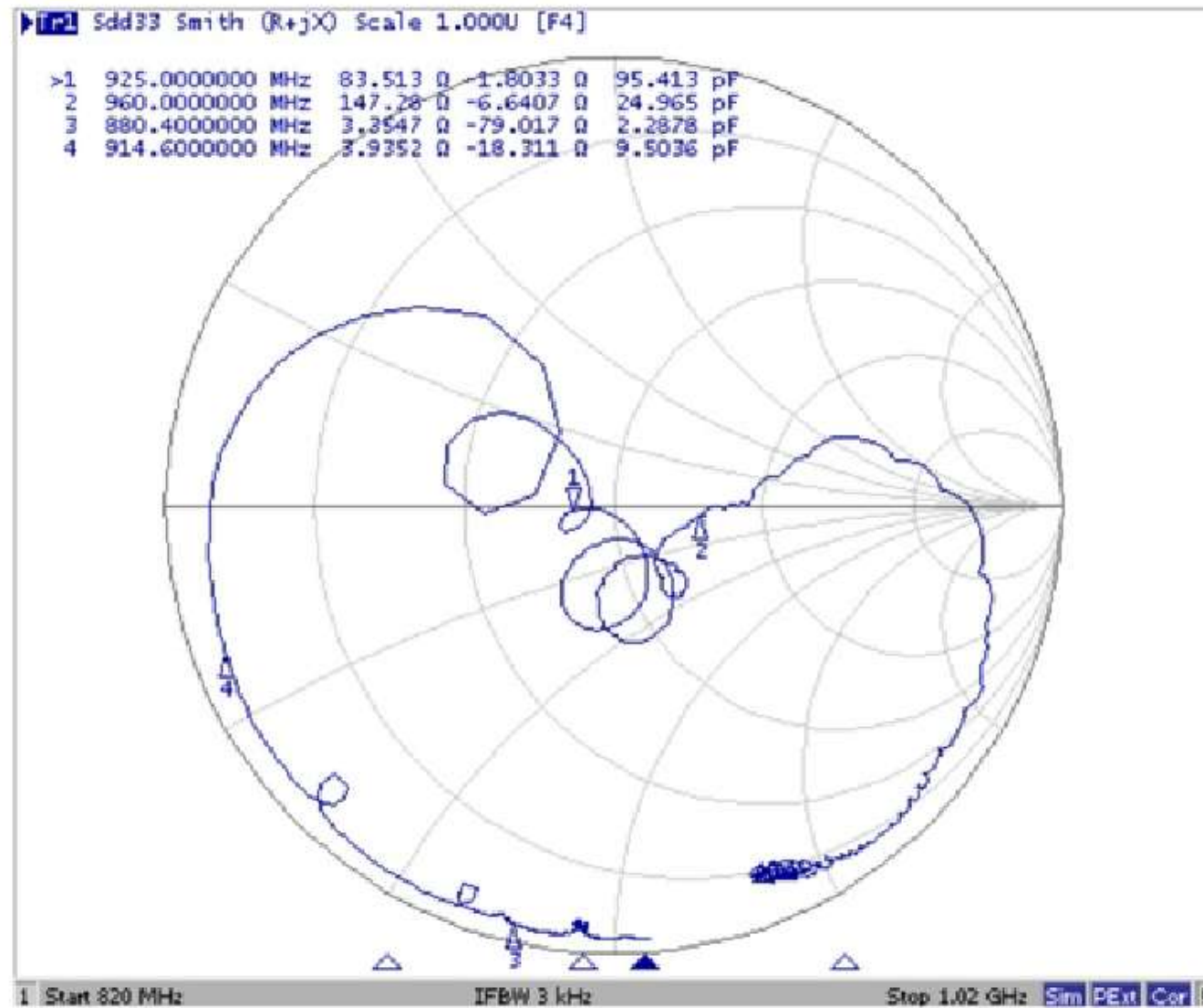
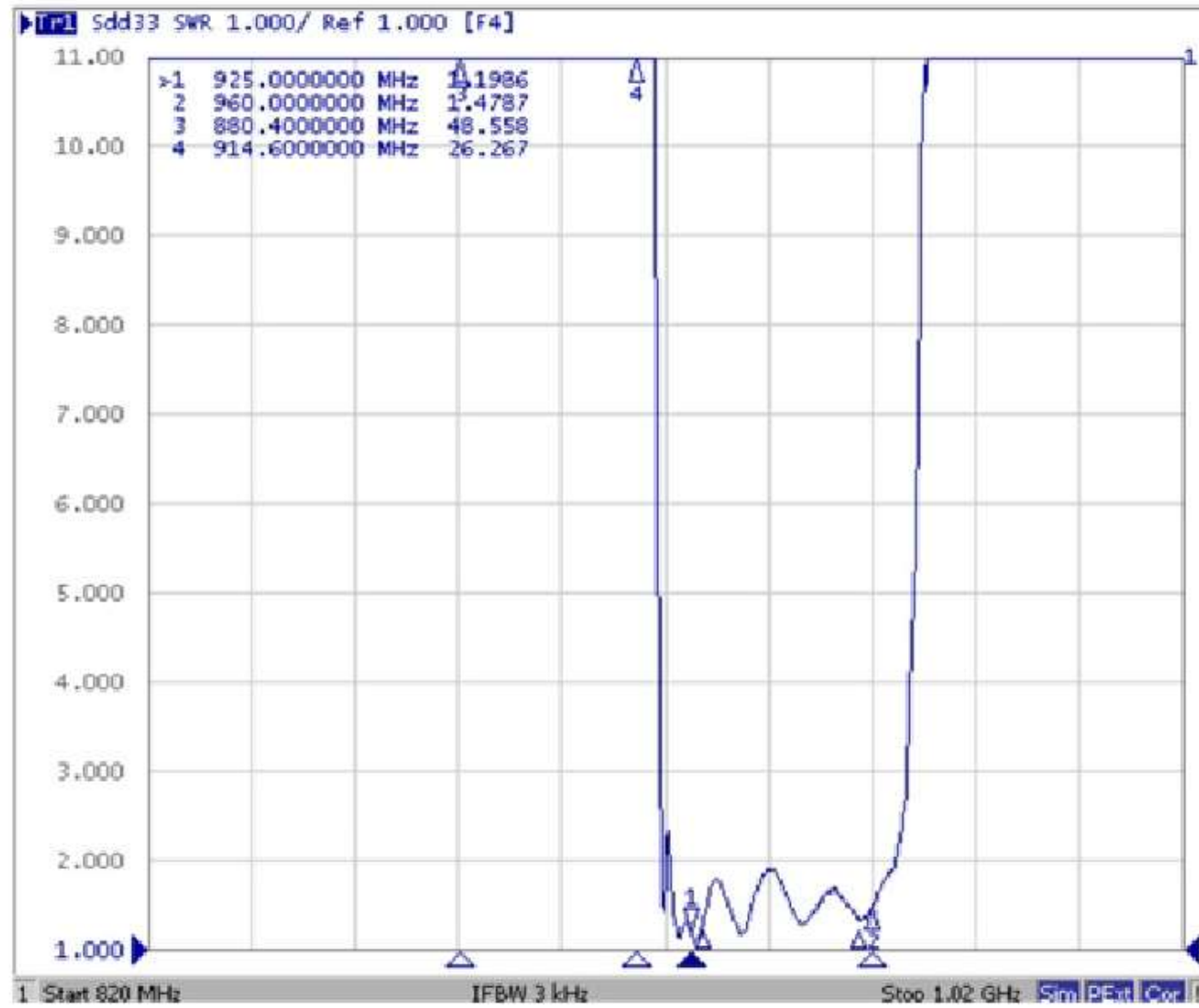

Ant Port

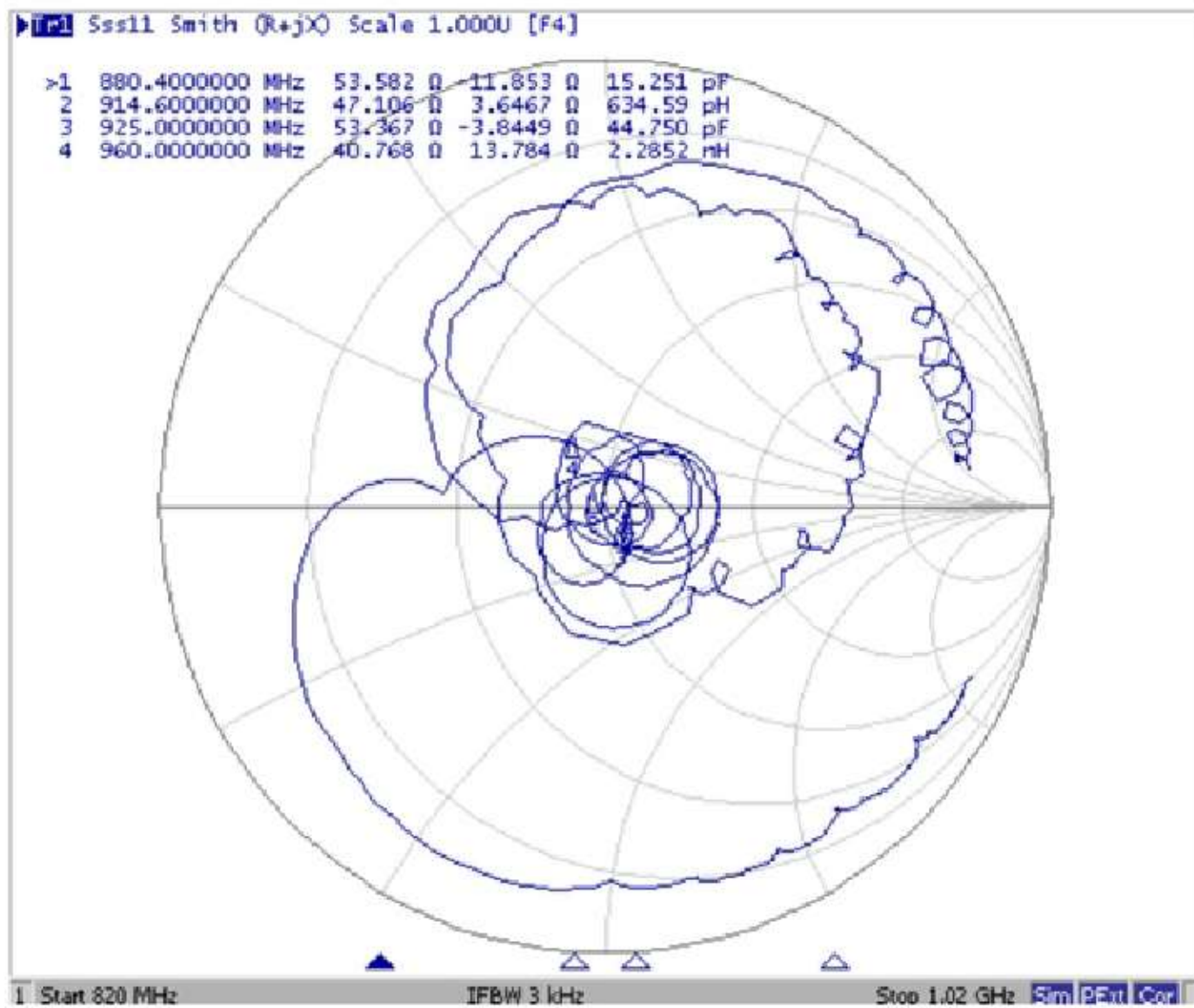
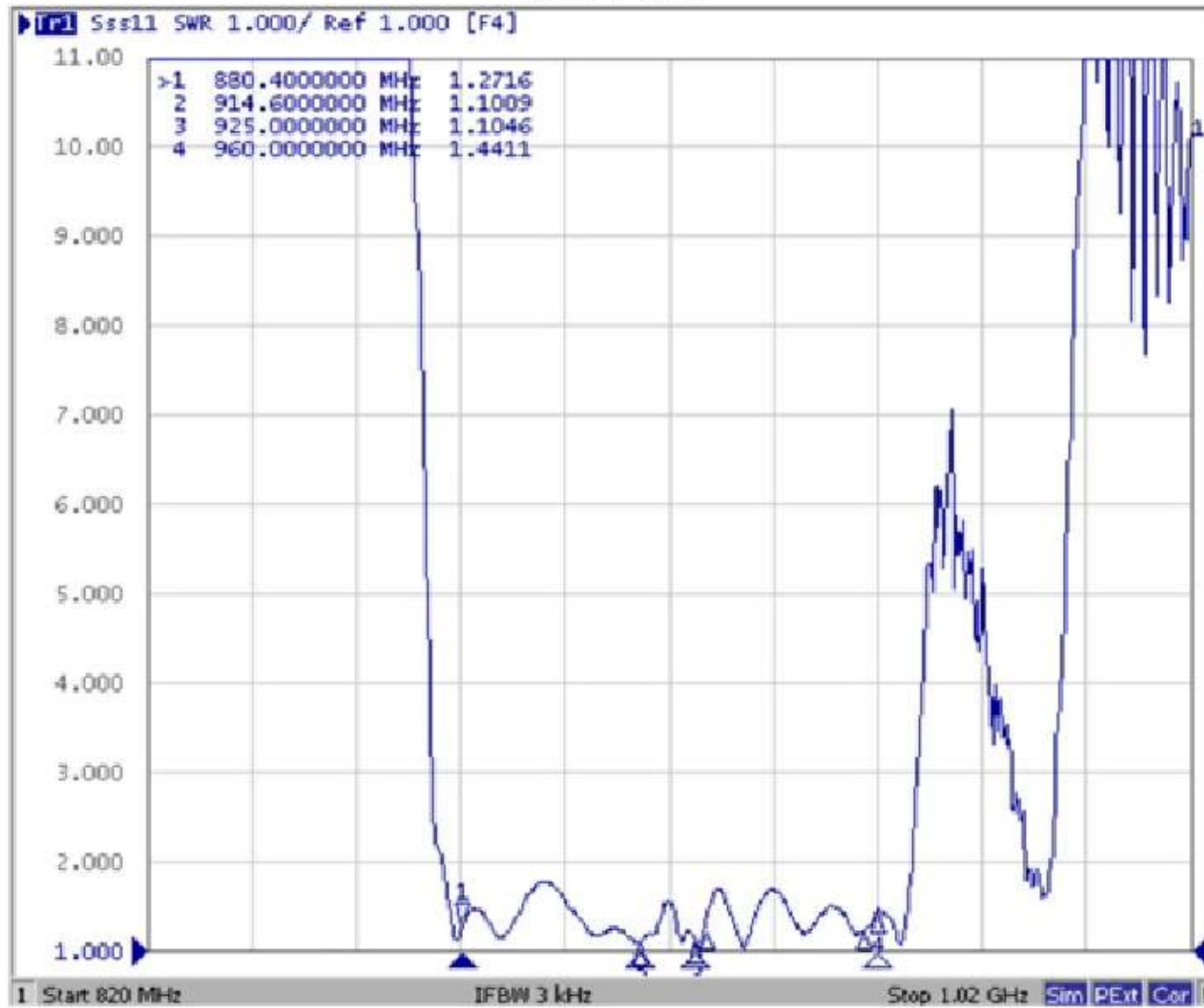

Ant to Rx (Amplitude balance)

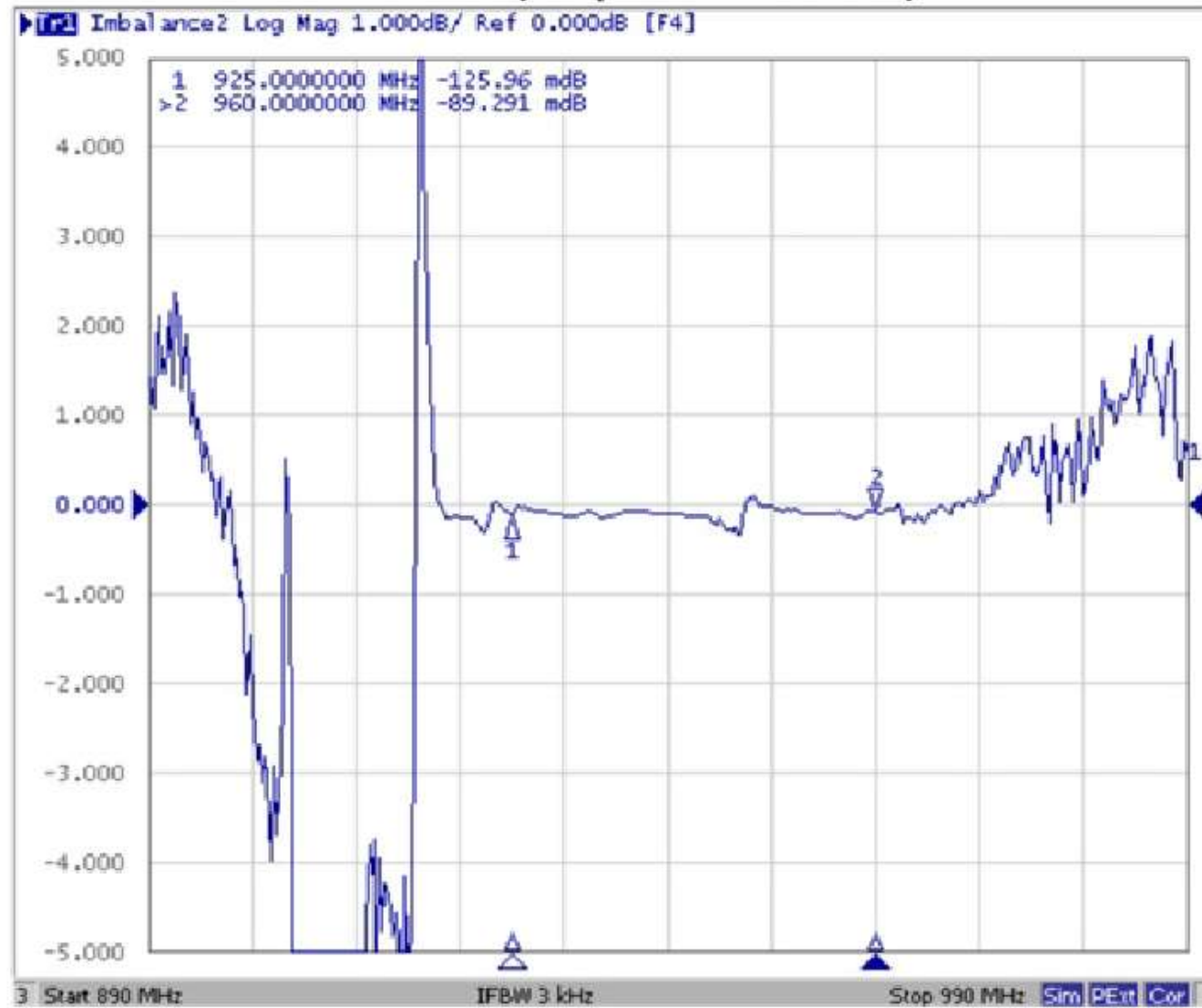

Ant to Rx (Phase balance)

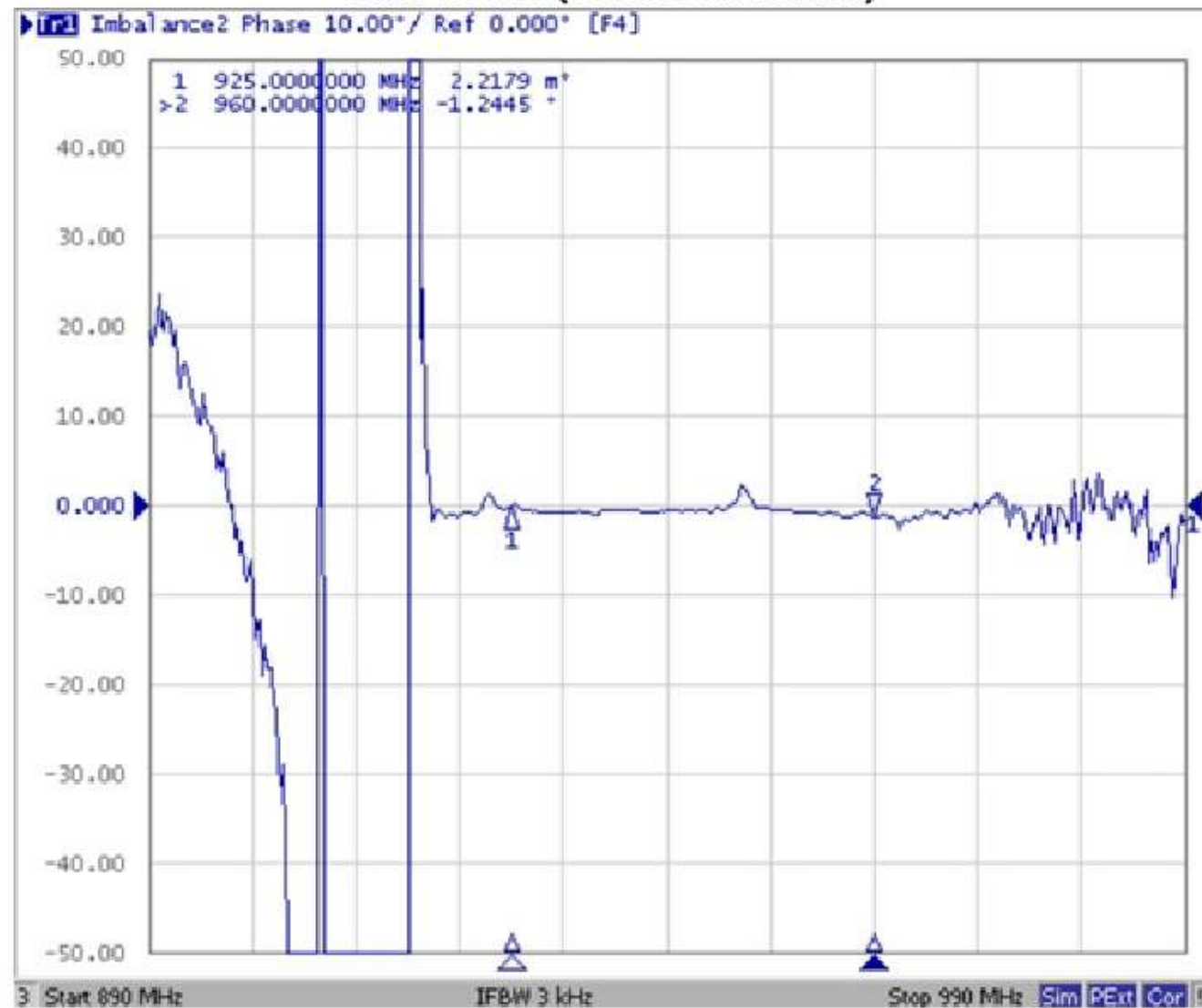

Tx to Ant (Wide span)

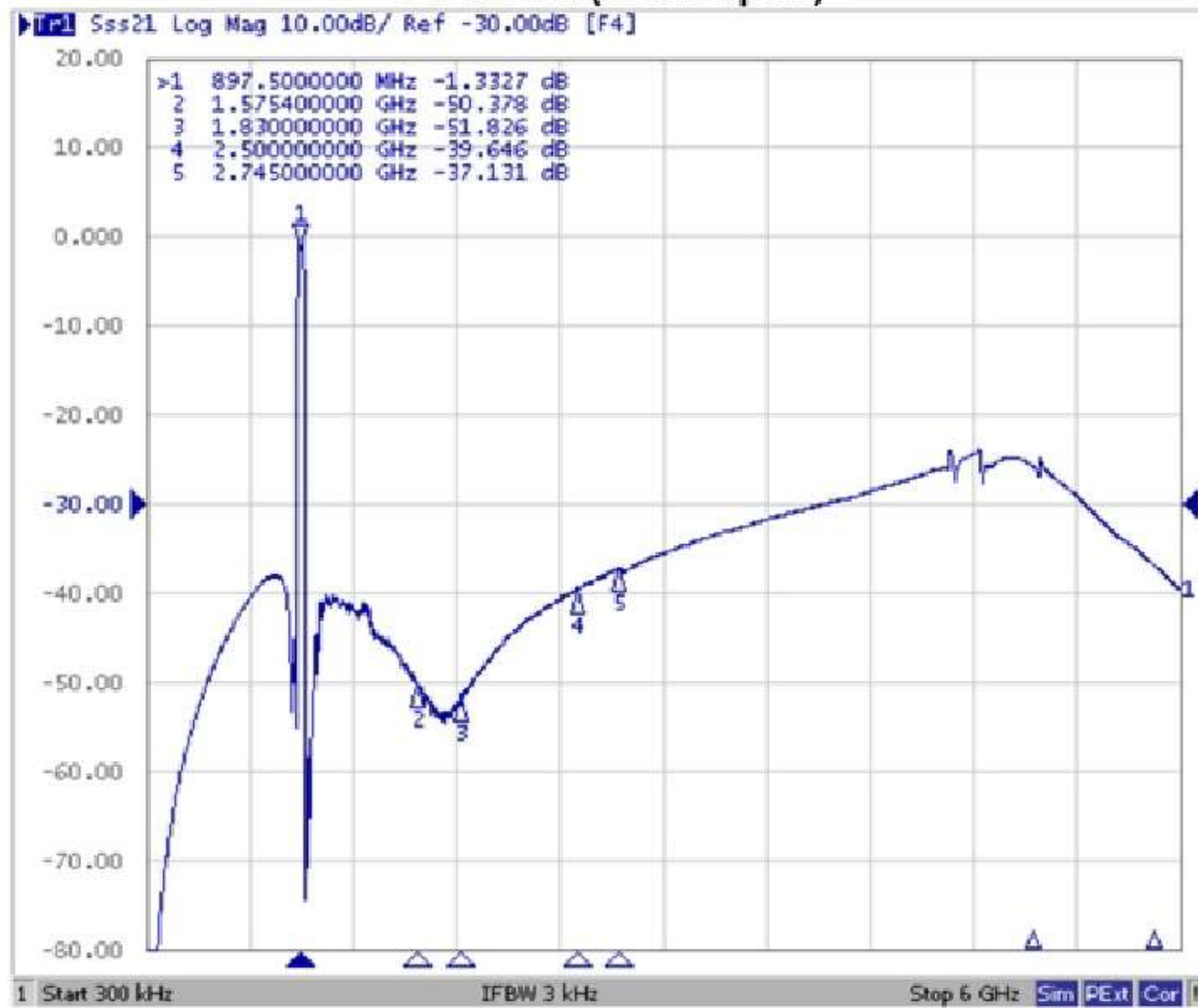

Ant to Rx (Wide span)

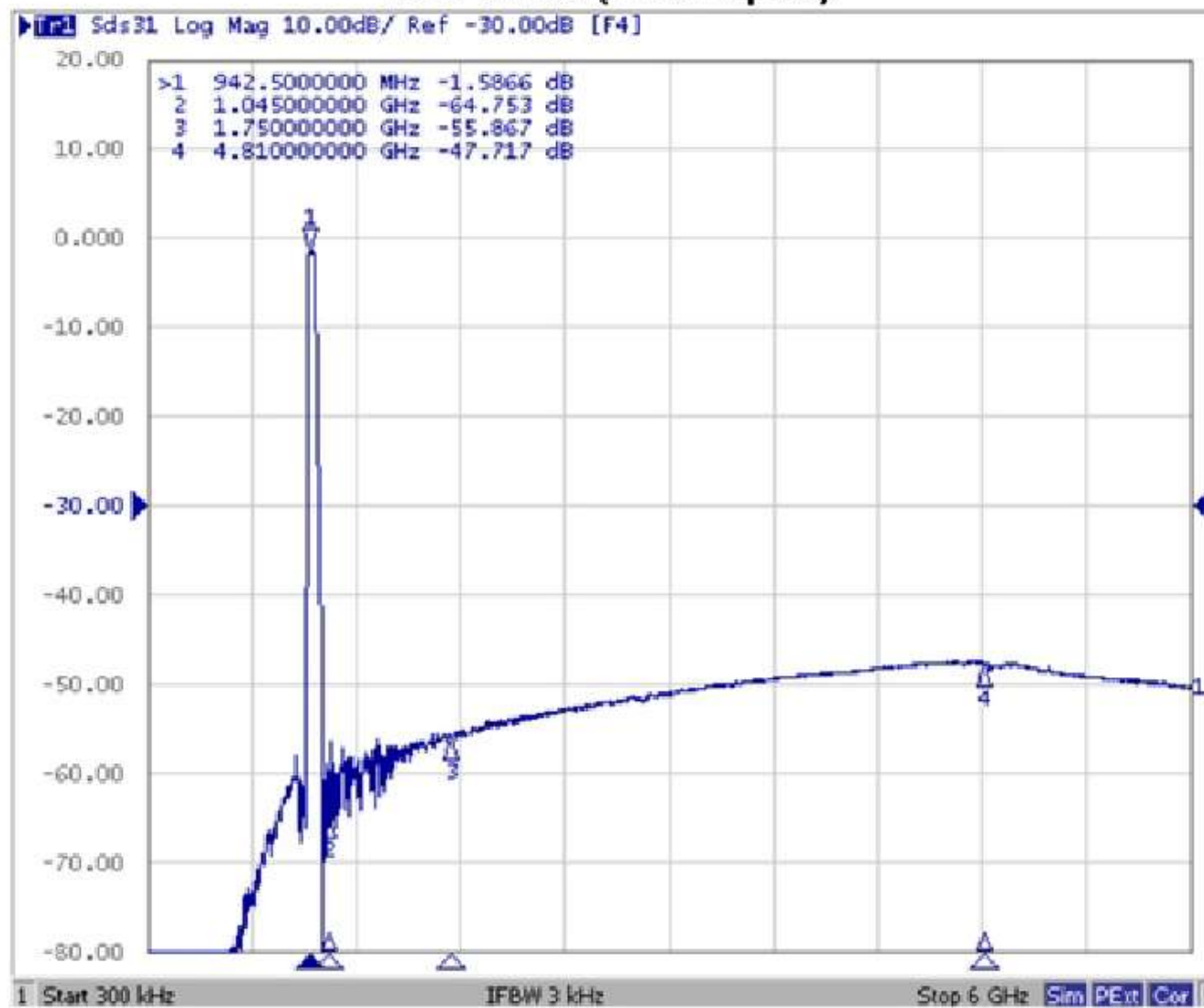

E. PCB Footprint:

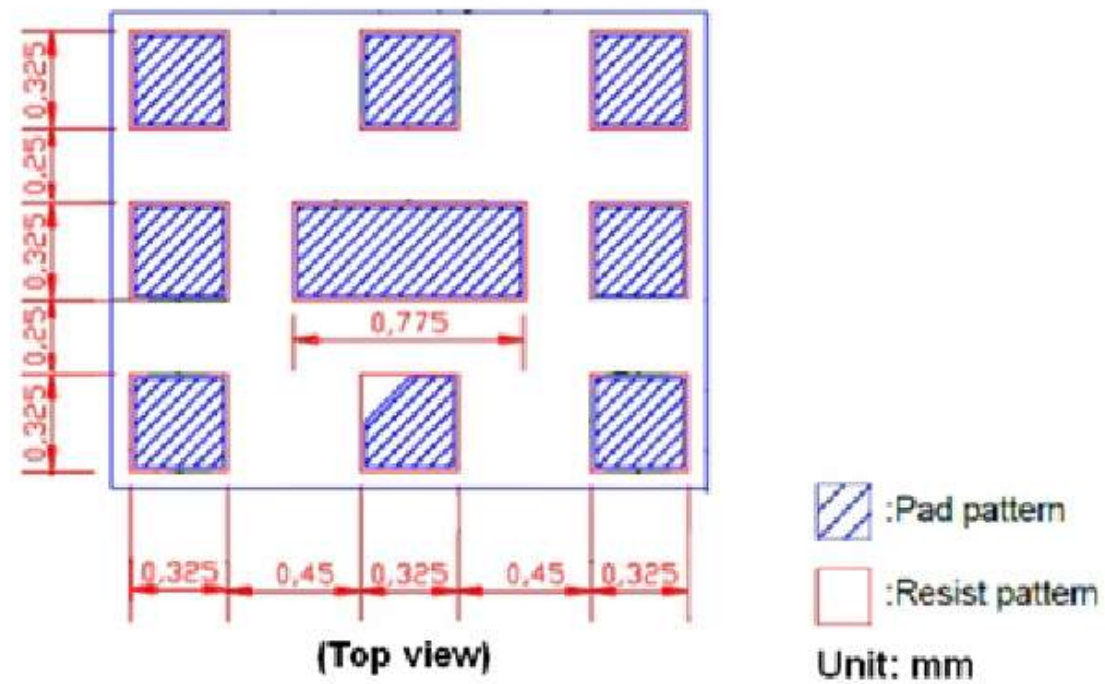

F. OUTLINE DRAWING:

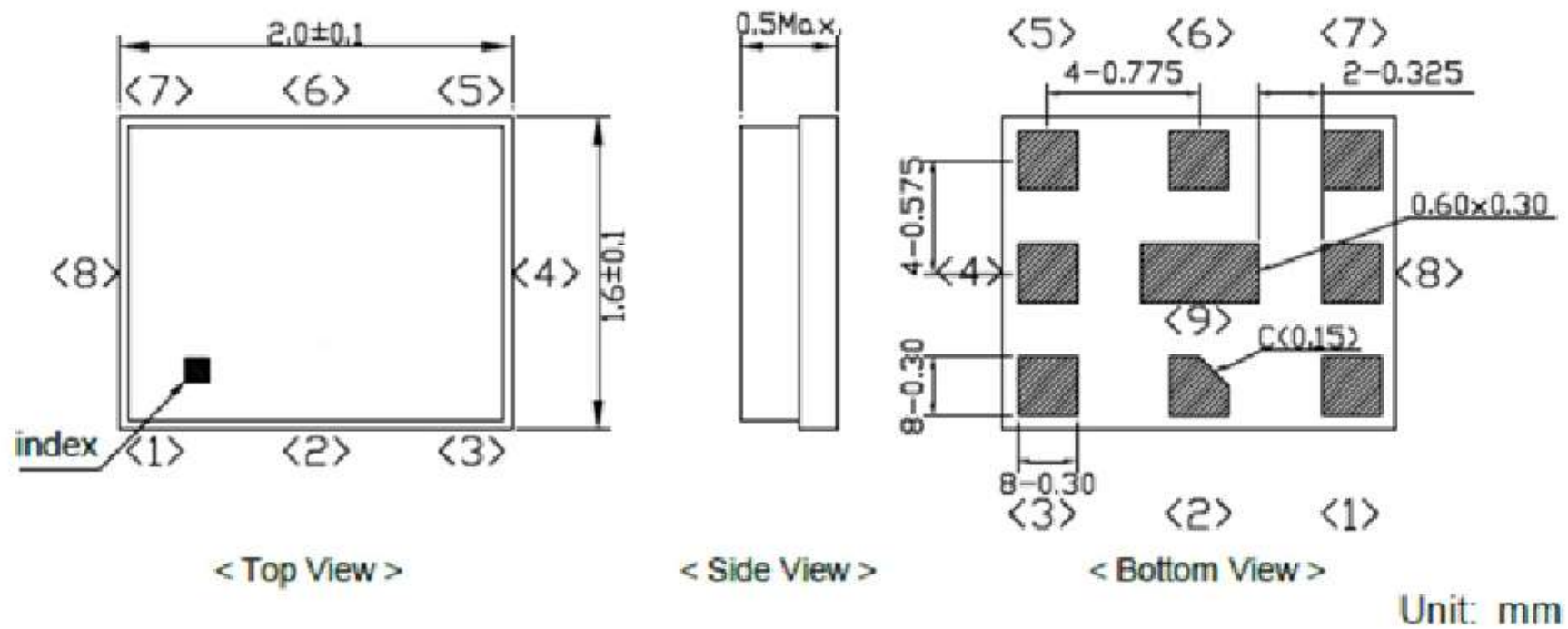

Pin Configuration

Pin No.	Pin name	Description
1	Rx	Receiver Pin (balanced)
2	GND	Ground Pin
3	Tx	Transmitter Pin
4	GND	Ground Pin
5	GND	Ground Pin
6	ANT	Antenna Pin
7	GND	Ground Pin
8	Rx	Receiver Pin (balanced)
9	GND	Ground Pin

Top View (Sample Production):



Top View (Mass Production):

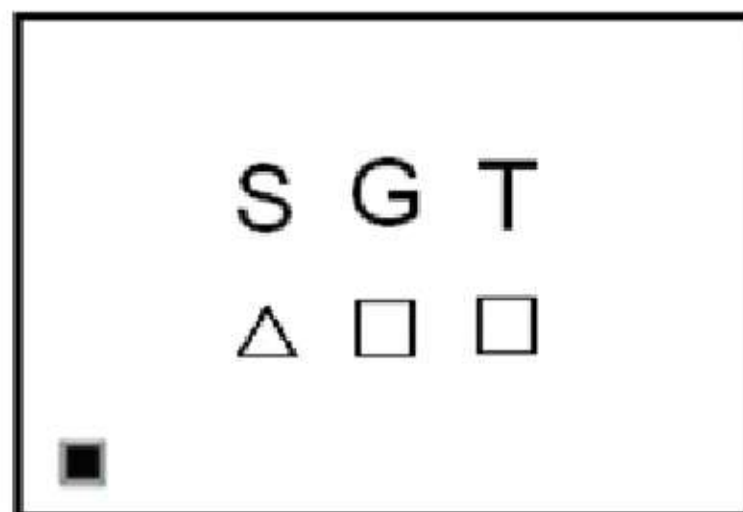

Δ: Date Code (Follow below table)

□: Lot No. (Indicated by 0~9 or A to Z and a to z, except I, O, i, o and l)

Date Code table:

Year	Jan.	Feb.	Mar.	Apr.	May	Jun.	Jul.	Aug.	Sep.	Oct.	Nov.	Dec.
2017	A	B	C	D	E	F	G	H	J	K	L	M
2018	N	P	Q	R	S	T	U	V	W	X	Y	Z
2019	a	b	c	d	e	f	g	h	J	k	l	m
2020	n	p	q	r	s	t	u	v	w	x	y	z

G. PACKING: (Ref: WI-75M03)

1. REEL DIMENSION

(Please refer to FR-75D10 for packing quantity)

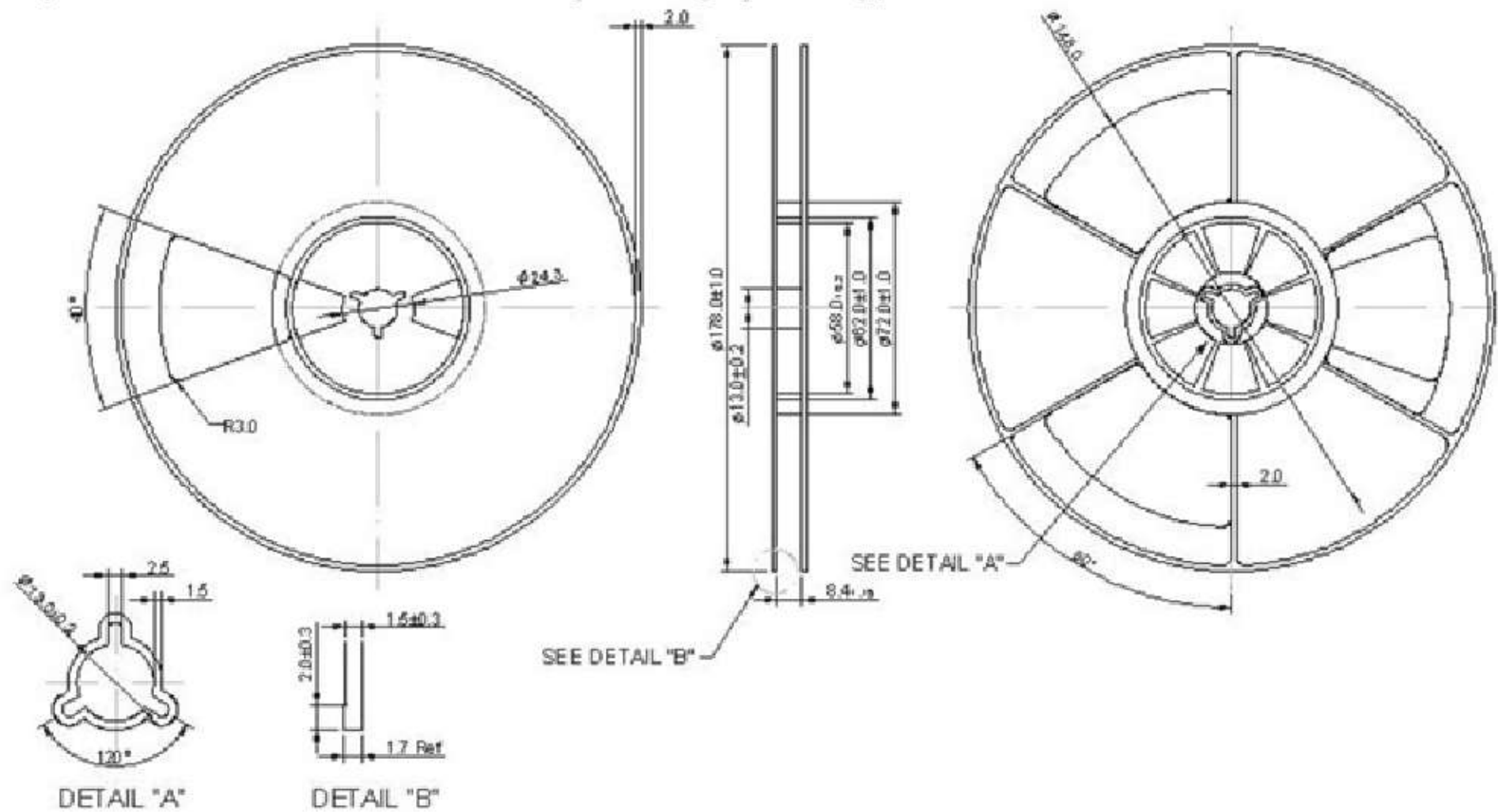

2. TAPE DIMENSION

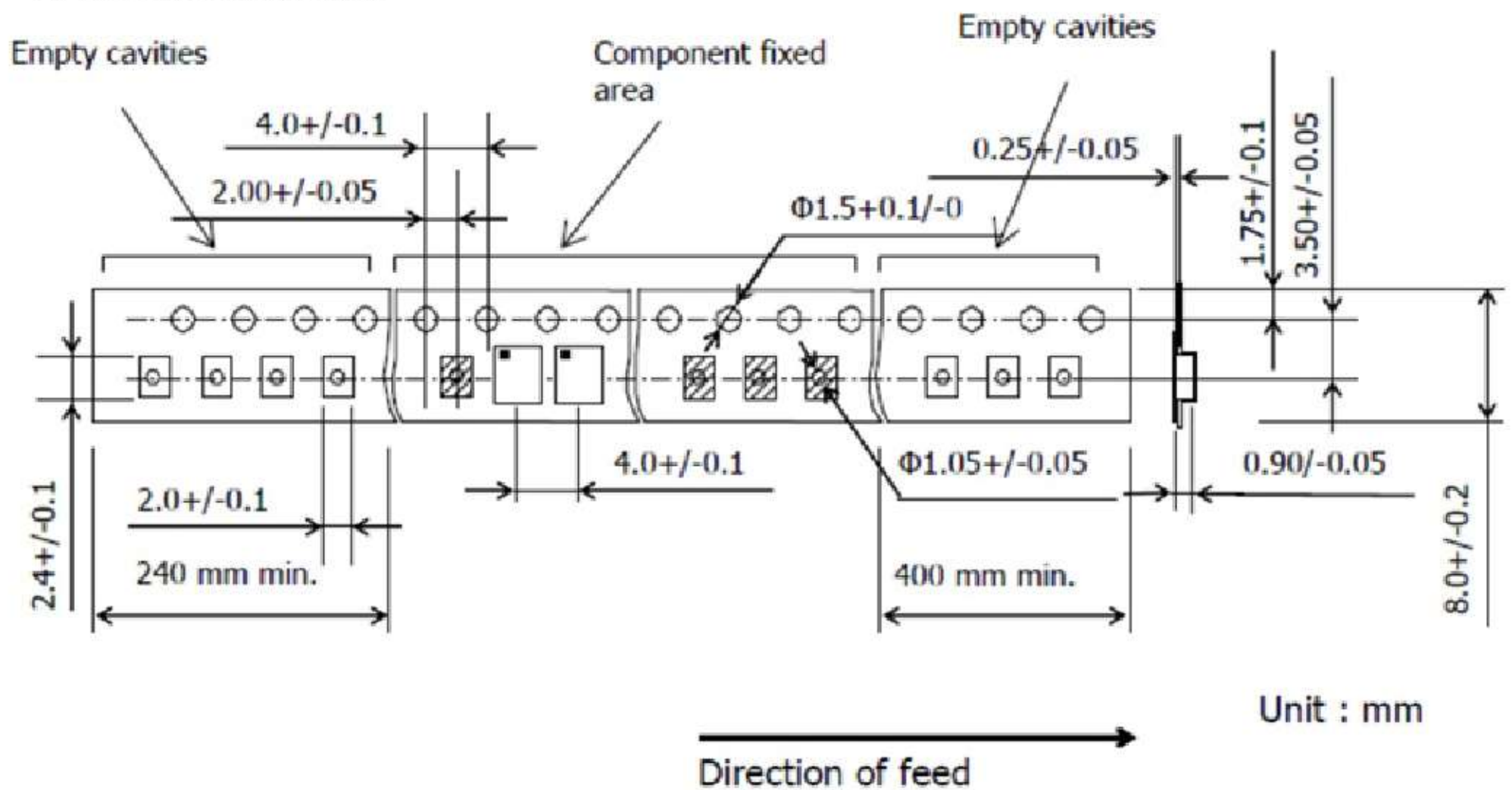

H. Recommended Reflow Profile:

1. Preheating shall be fixed at 150~180°C for 60~90 seconds.
2. Ascending time to preheating temperature 150°C shall be 30 seconds min.
3. Heating shall be fixed at 220°C for 50~80 seconds and at 260°C +0/-5°C peak (20~40sec).
4. Time: 2 times.

