

SAW Filter 725.5 MHz SMD 3.0X3.0 mm

MODEL NO.:TA2615A

REV. NO.:1.0

A. MAXIMUM RATING:

1. Input Power Level: 15 dBm
2. DC Voltage : 0 V
3. Operating Temperature: +0 °C to +85 °C
4. Storage Temperature: -40 °C to +85 °C

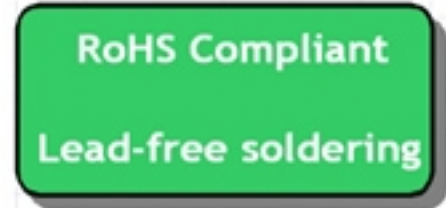

Electrostatic Sensitive Device (ESD)

B. ELECTRICAL CHARACTERISTICS:

Terminating source impedance (single) : $Z_s = 50 \Omega$

Terminating load impedance (single) : $Z_L = 50 \Omega$

Item	Unit	Min.	Type.	Max.
Center Frequency	MHz	-	725.5	-
Insertion Loss (703 ~ 748 MHz)	dB	-	2.5	3.5
Amplitude ripple (703 ~ 748 MHz)	dB	-	1.5	2.5
VSWR (703 ~ 748 MHz)	-	-	2.2	2.5
Attenuation				
10 ~ 670 MHz	dB	25	31	-
670 ~ 690 MHz	dB	15	37	-
758 ~ 803 MHz	dB	10	24	-
803 ~ 1000 MHz	dB	25	30	-
1000 ~ 3000 MHz	dB	25	30	-
Temperature Coefficient of Frequency	ppm/C°	-	-36	-

C. TEST CIRCUIT:

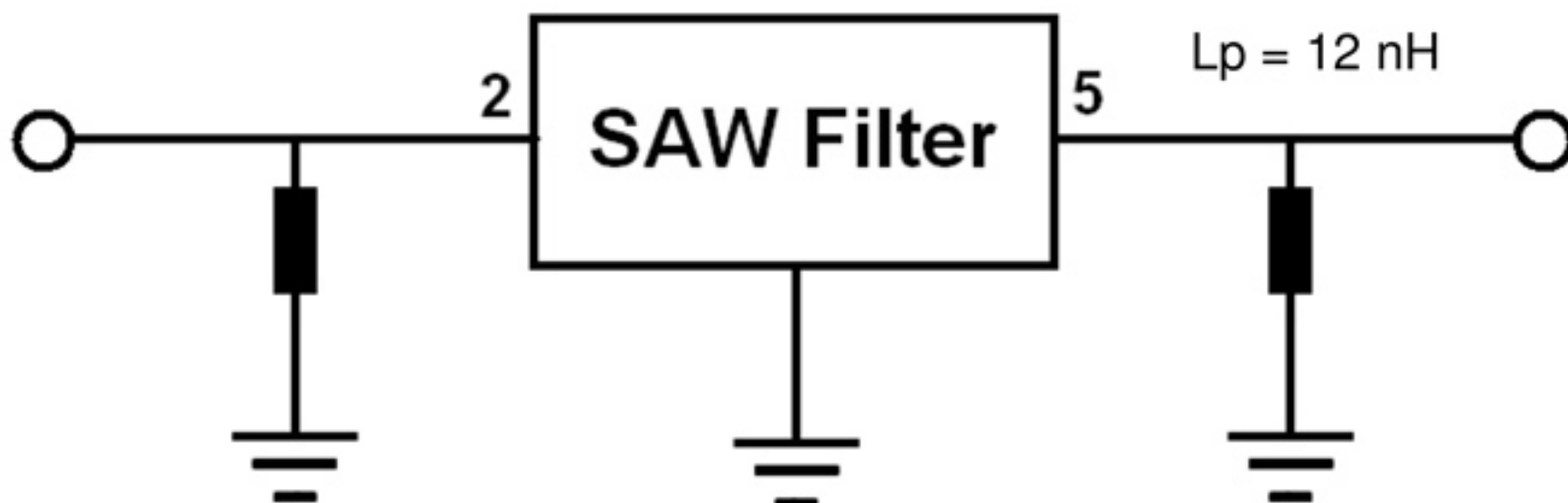

D. OUTLINE DRAWING:

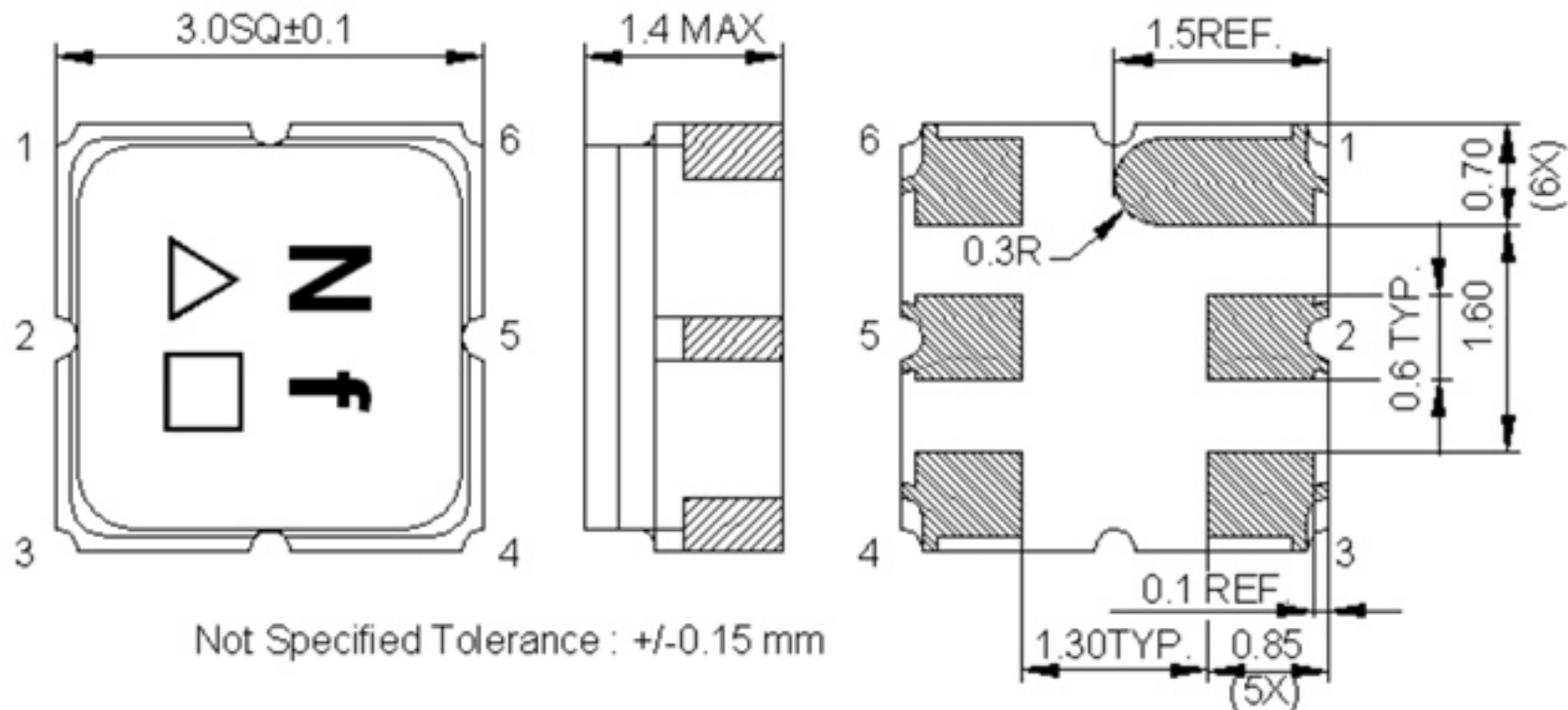

Not Specified Tolerance : +/-0.15 mm

2: Input

5: Output

Other: Ground

Unit: mm

△ : Year Code (2009->9, 2010->0, ..., 2018->8)

□ : Date Code (Follow the table from planner each year)

WK01	WK02	WK03	WK04	WK05	WK06	WK07	WK08	WK09	WK10	WK11	WK12	WK13
A	B	C	D	E	F	G	H	I	J	K	L	M
WK14	WK15	WK16	WK17	WK18	WK19	WK20	WK21	WK22	WK23	WK24	WK25	WK26
N	O	P	Q	R	S	T	U	V	W	X	Y	Z
WK27	WK28	WK29	WK30	WK31	WK32	WK33	WK34	WK35	WK36	WK37	WK38	WK39
a	b	c	d	e	f	g	h	i	j	k	l	m
WK40	WK41	WK42	WK43	WK44	WK45	WK46	WK47	WK48	WK49	WK50	WK51	WK52
n	o	p	q	r	s	t	u	v	w	x	y	z

E. Frequency Characteristics:

Span 400 MHz

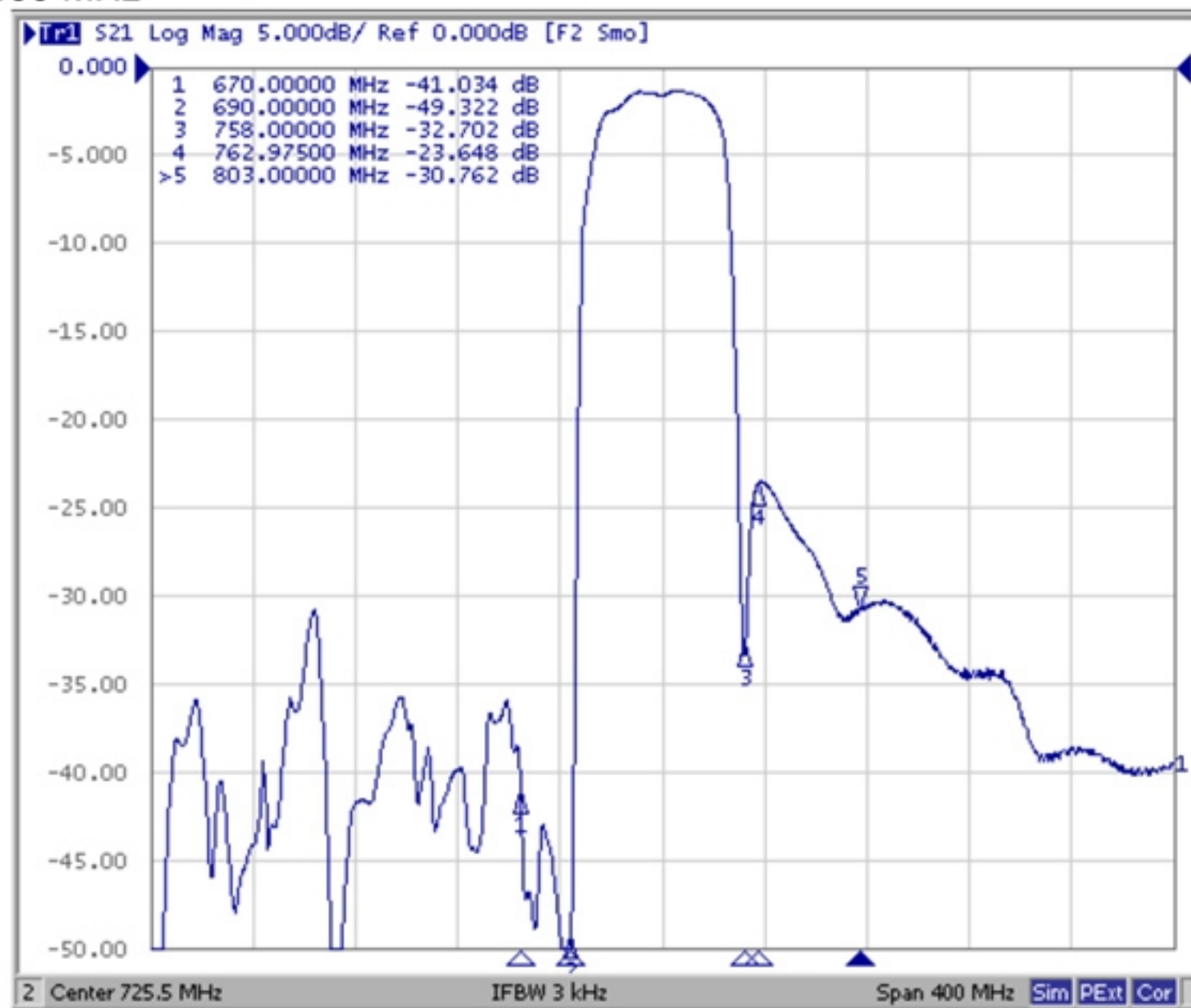

Span 3000 MHz



Span 100 MHz

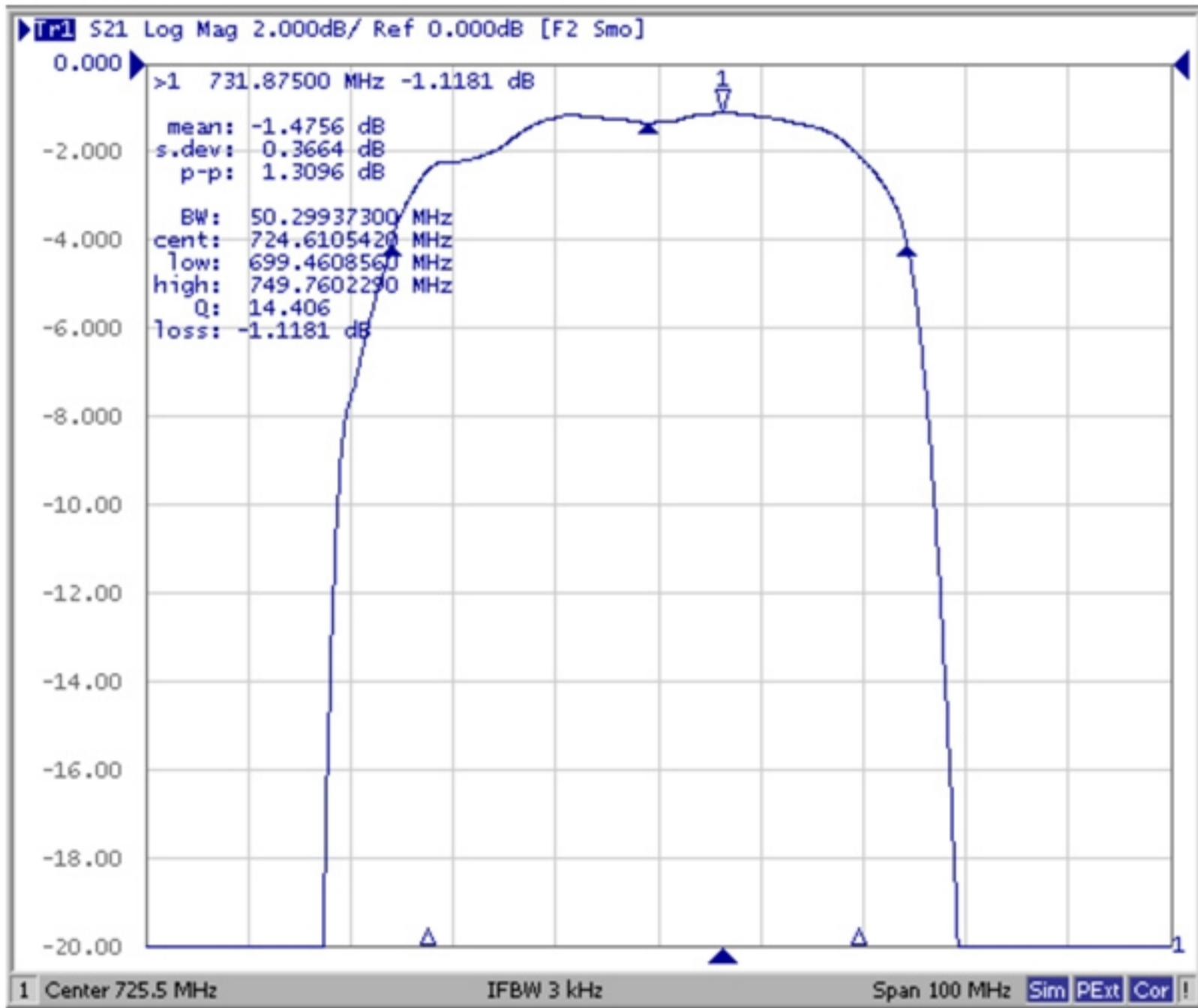

Reflection Characteristic

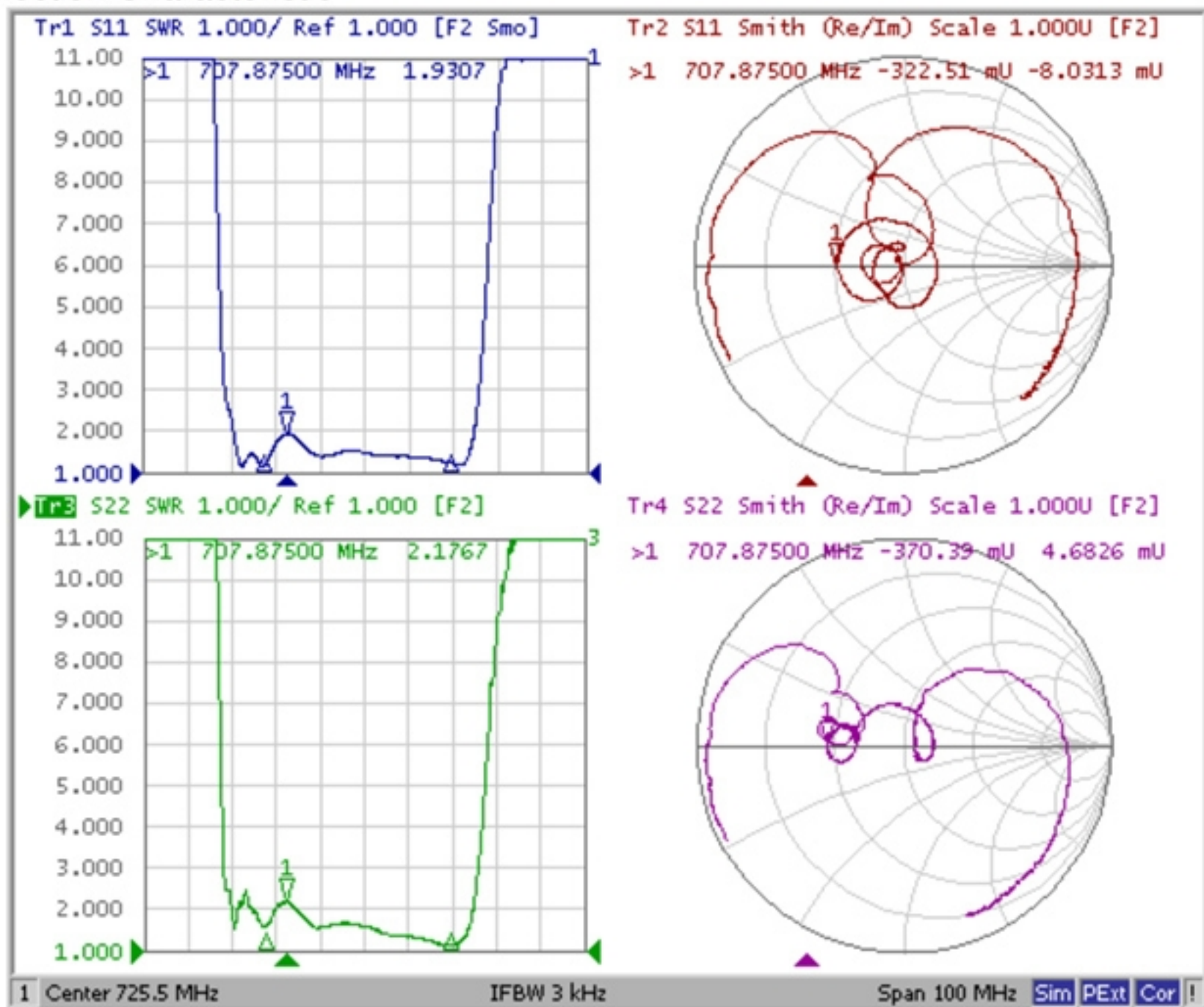

F. PCB FOOTPRINT:

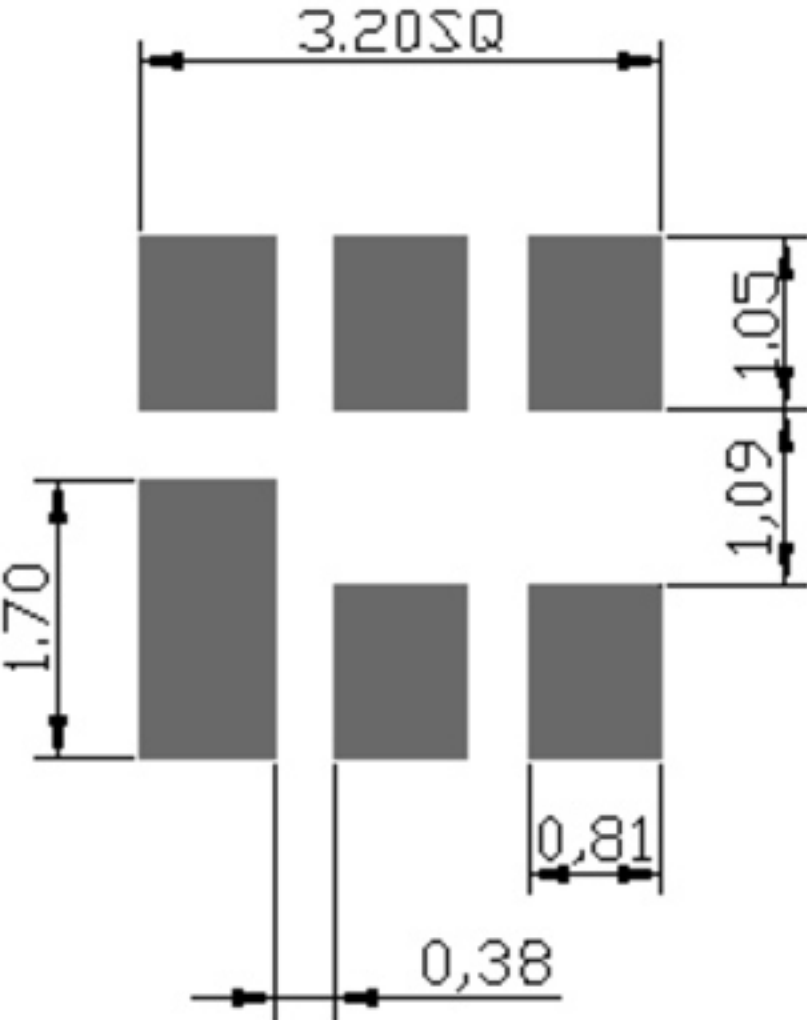

H. RECOMMENDED REFLOW PROFILE :

1. Preheating shall be fixed at $150\sim 180^{\circ}\text{C}$ for 60~90 seconds.
2. Ascending time to preheating temperature 150°C shall be 30 seconds min.
3. Heating shall be fixed at 220°C for 50~80 seconds and at $260^{\circ}\text{C}+0/-5^{\circ}\text{C}$ peak (20~40sec).
4. Time: 2 times.

