

SAW Filter MHz 763MHz 10 MHz BW SMD1.1x0.9mm

MODEL NO.:TA2509B

REV. NO.:1

A. MAXIMUM RATING:

1. Input Power Level: 10dBm
2. DC Voltage : 5V
3. Operating Temperature: -40 °C to +85 °C
4. Storage Temperature: -40 °C to +100 °C
5. Moisture Sensitivity Level: Level 3
6. ESD 50V(MM) 100V(HBM)

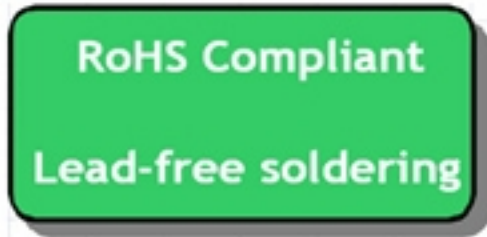

Electrostatic Sensitive Device (ESD)

B. ELECTRICAL CHARACTERISTICS:

Terminating source impedance(Unbalanced)⁽¹⁾ : $Z_s = 50 \Omega$

Terminating load impedance(Unbalanced)⁽¹⁾ : $Z_L = 50 \Omega$

Item	Unit	Min.	Typ.	Max.	Note
Center Frequency Fc	MHz	-	763	-	-
Insertion Loss (758~768 MHz) IL	dB	-	2.2	3.2	(*1)
Amplitude ripple(758~768 MHz)	dBp-p	-	0.7	2.0	-
VSWR (758~768 MHz)		-	1.8	2.1	-
Attenuation (reference level from 0 dB)					
50~ 698 MHz	dB	30	42	-	-
698 ~ 716 MHz	dB	35	49		
788 ~ 798 MHz	dB	44	49	-	Tx
2400 ~ 2500 MHz	dB	35	42	-	-
4900 ~ 6000 MHz	dB	30	37	-	-

(*1) Specification of insertion loss excludes loss that comes from the test board.

C.OUTLINE DRAWING:

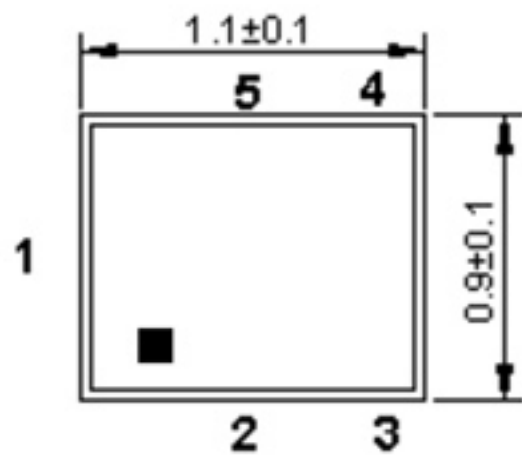

All tolerances are +/-0.05 mm unless otherwise specified
Coplanarity : 0.1 mm max.

1 to 5 : Pin No.

Unit : mm

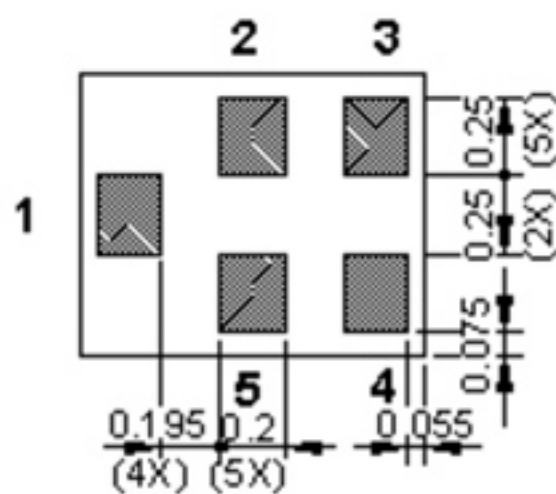

Pin assignment

Pin No.	Pin name	Description
1	In	Input
2	GND	Ground
3	GND	Ground
4	Out	Output
5	GND	Ground

Top View (Mass Production):



Marking name : QL

△ : Date Code

□ : Lot No. (Indicated by 0~9 or A to Z and a to z, except I, O, i, o and l)

date Code: (4-year cycle)

Year	Jan	Feb	Mar	Apr	May	Jun	Jul	Aug	Sep	Oct	Nov	Dec
2017 / 2021	A	B	C	D	E	F	G	H	J	K	L	M
2018 / 2022	N	P	Q	R	S	T	U	V	W	X	Y	Z
2019 / 2023	a	b	c	d	e	f	g	h	j	k	l	m
2020 / 2024	n	p	q	r	s	t	u	v	w	x	y	z

D.Evaluation Circuit :

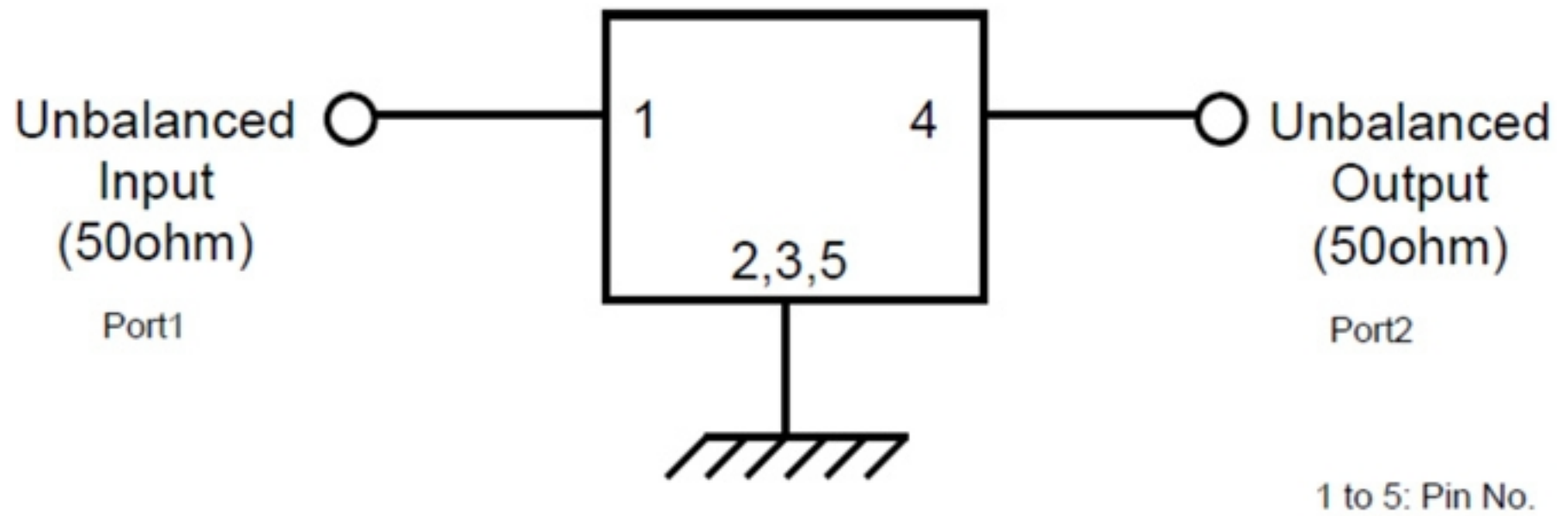

Source & Load Impedance: 50 Ω

E. PCB Footprint :

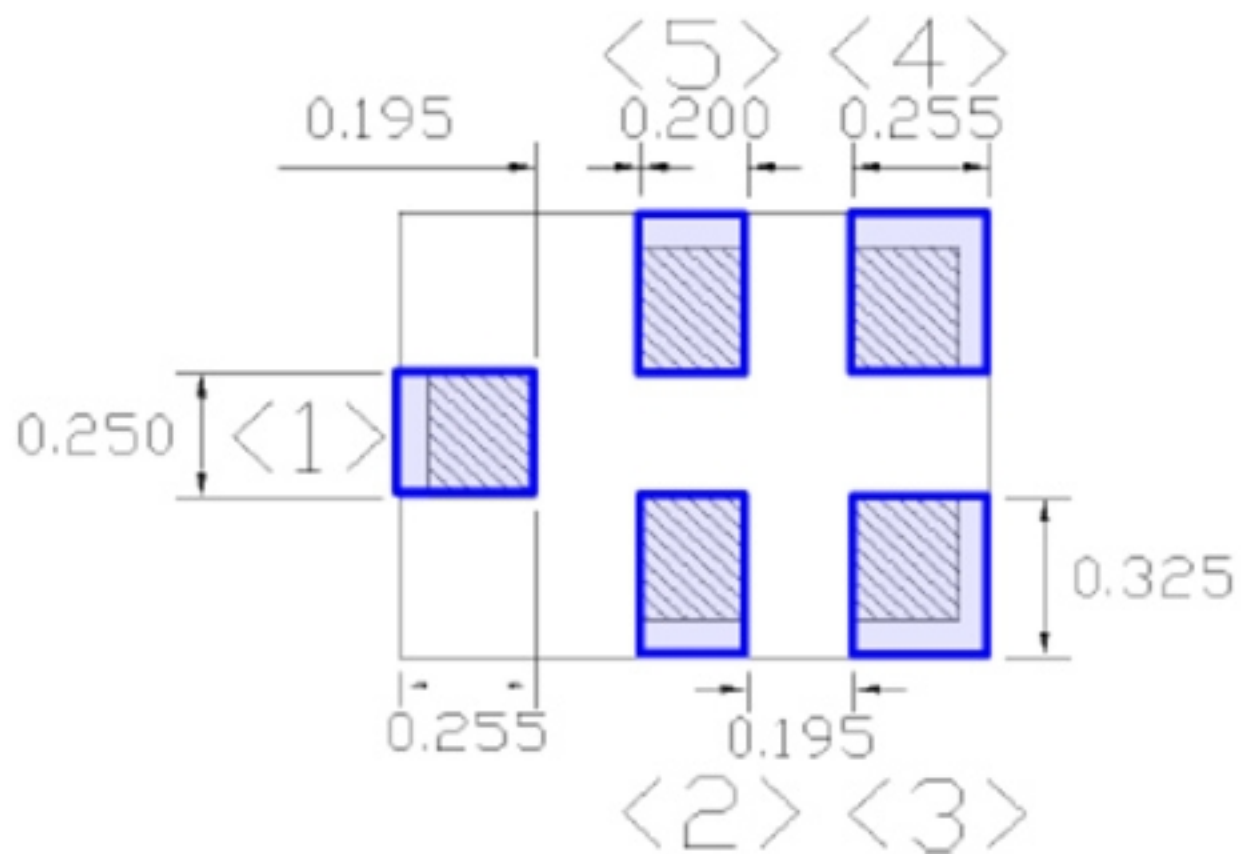

F. Frequency Characteristics

Passband

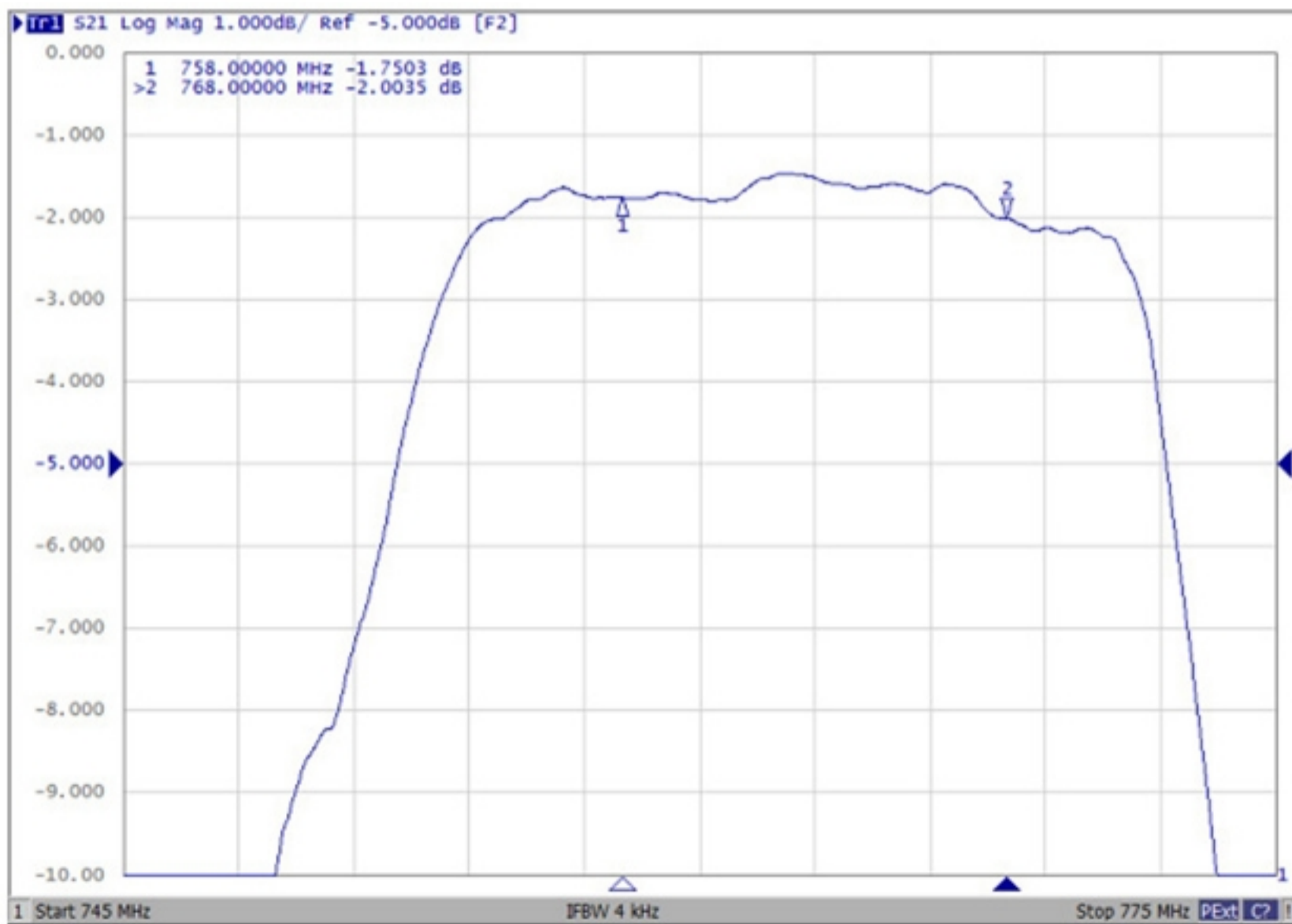
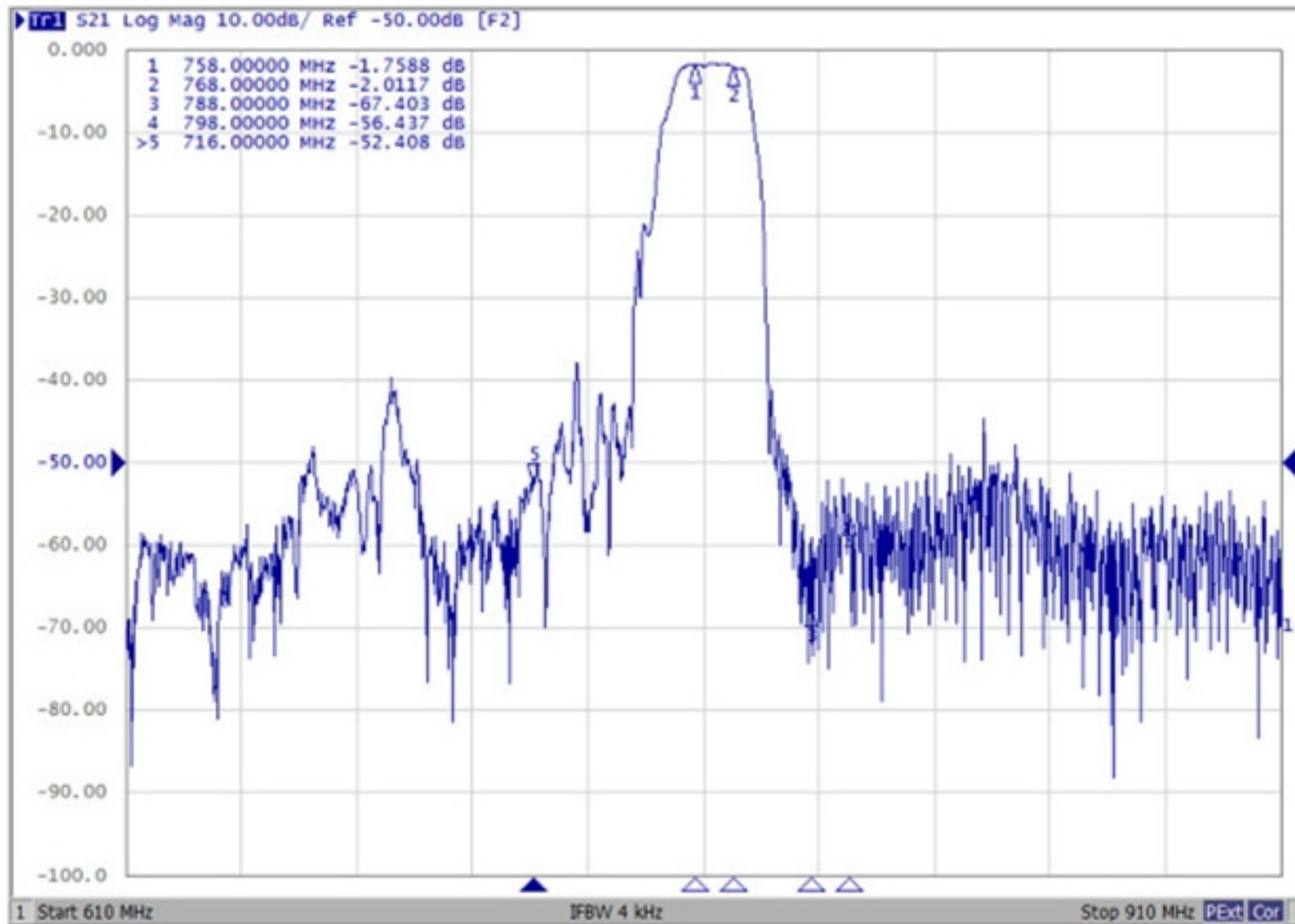

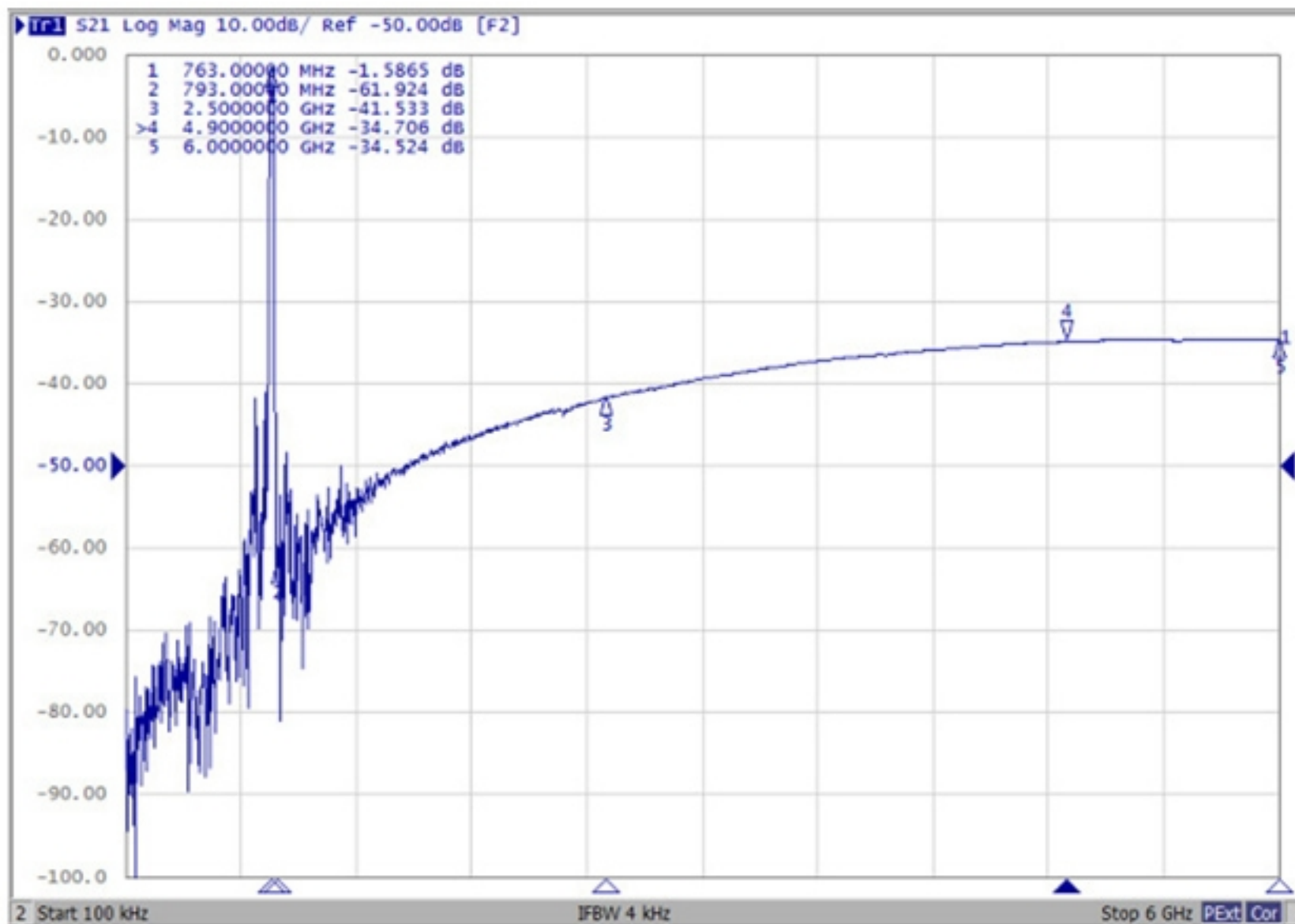

Reflection Functions :

S11 VSWR

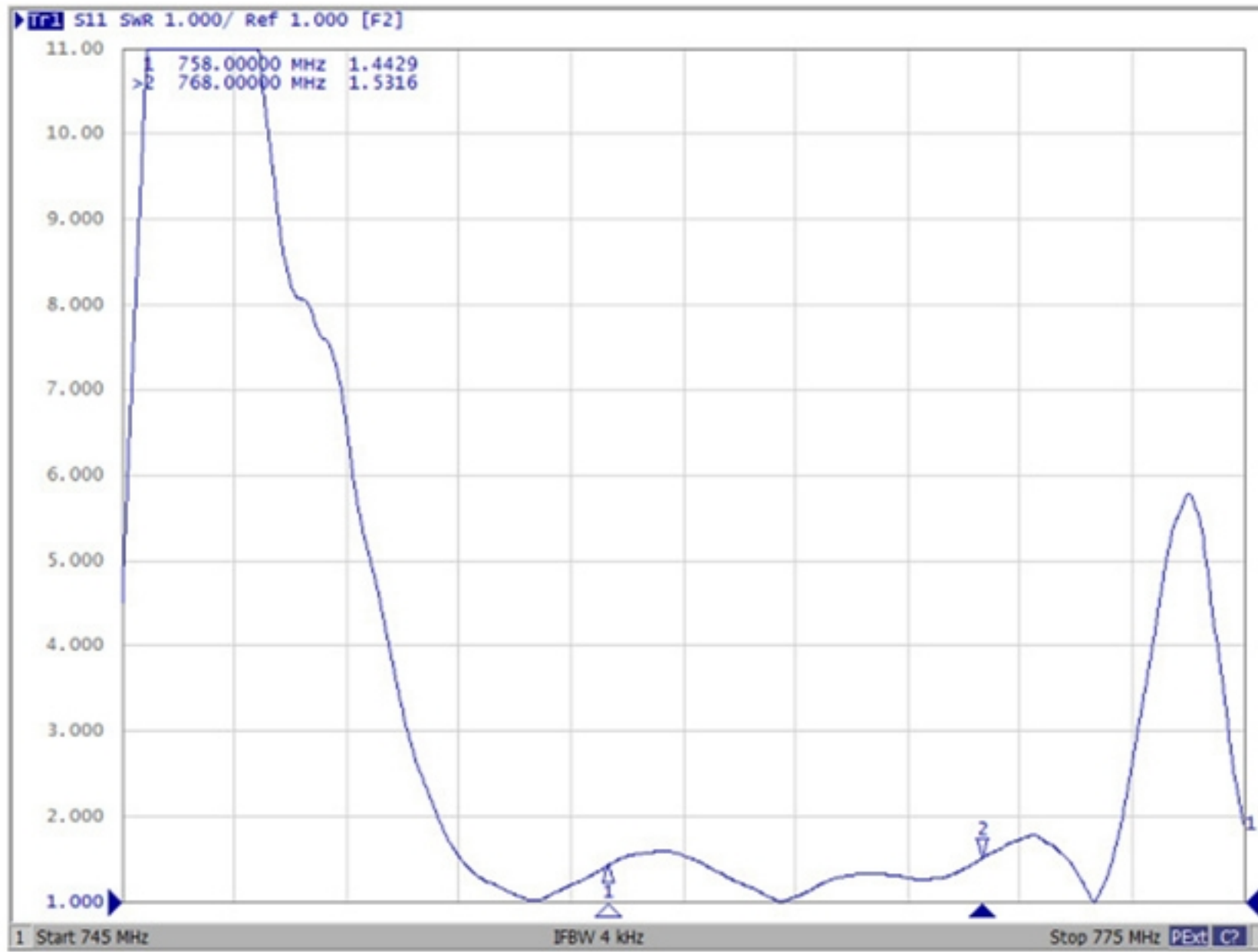

S22 VSWR

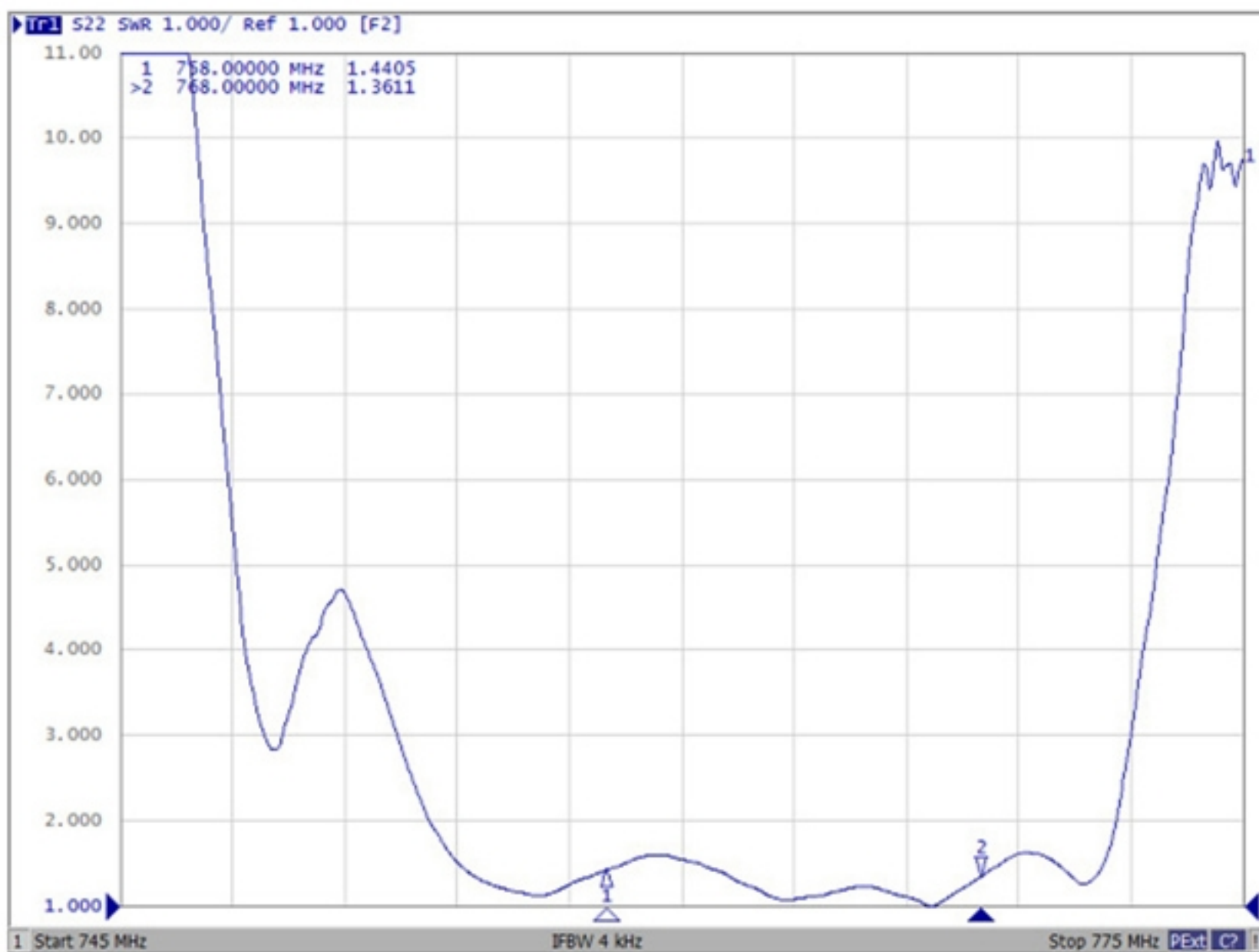

S11 Smith Chart

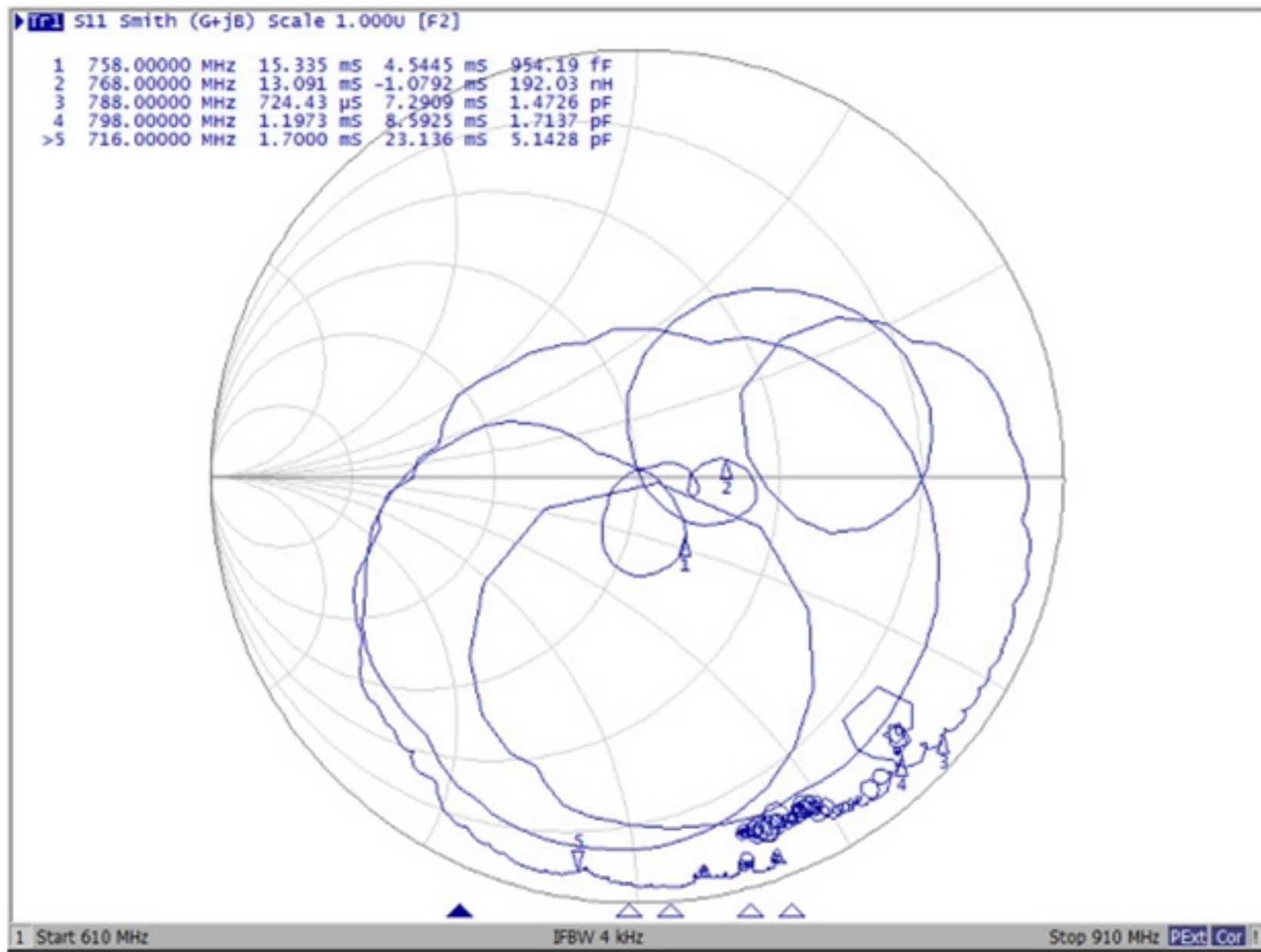

S22 Smith Chart

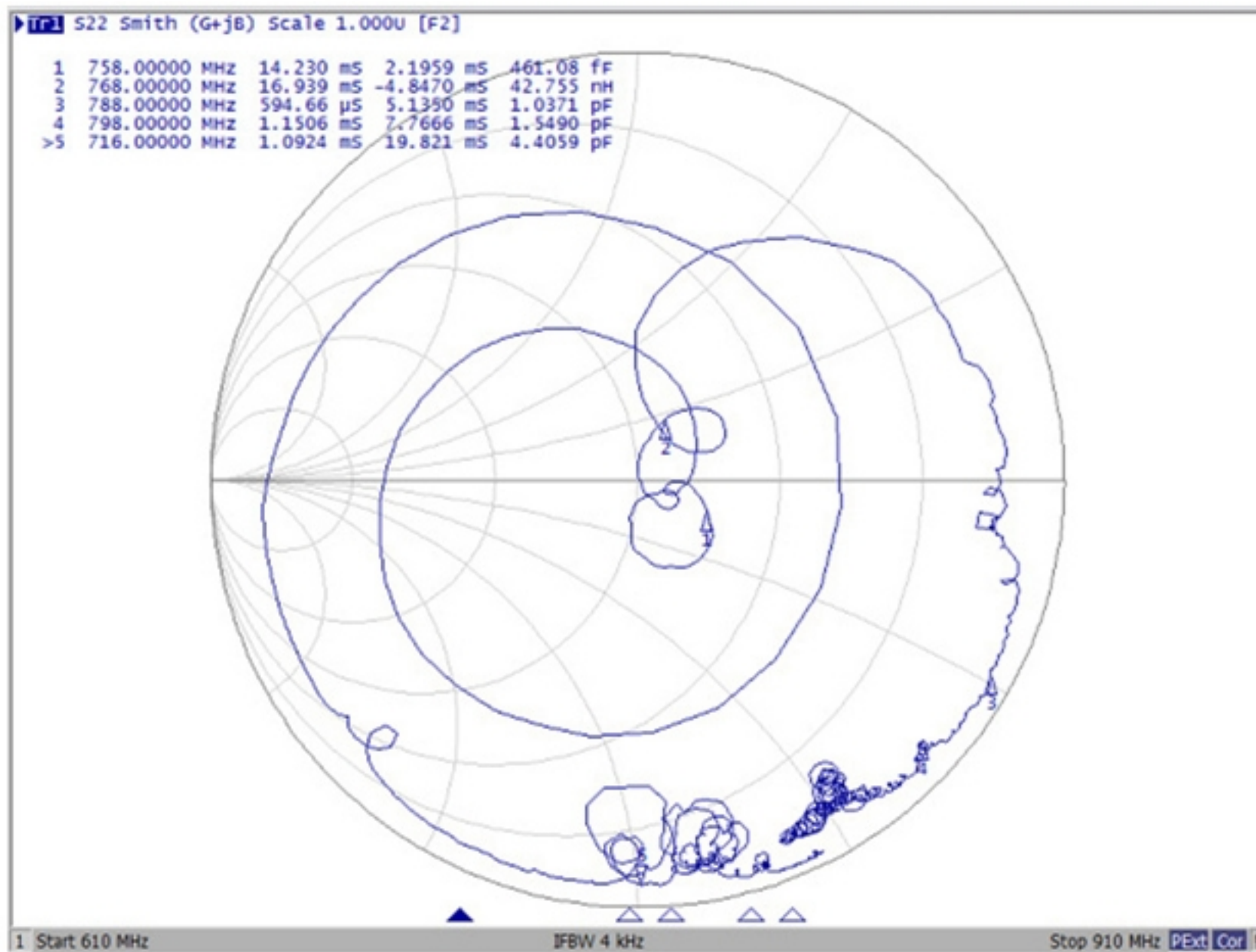

G. PACKING:

1. REEL DIMENSION

(Please refer to FR-75D10 for packing quantity)

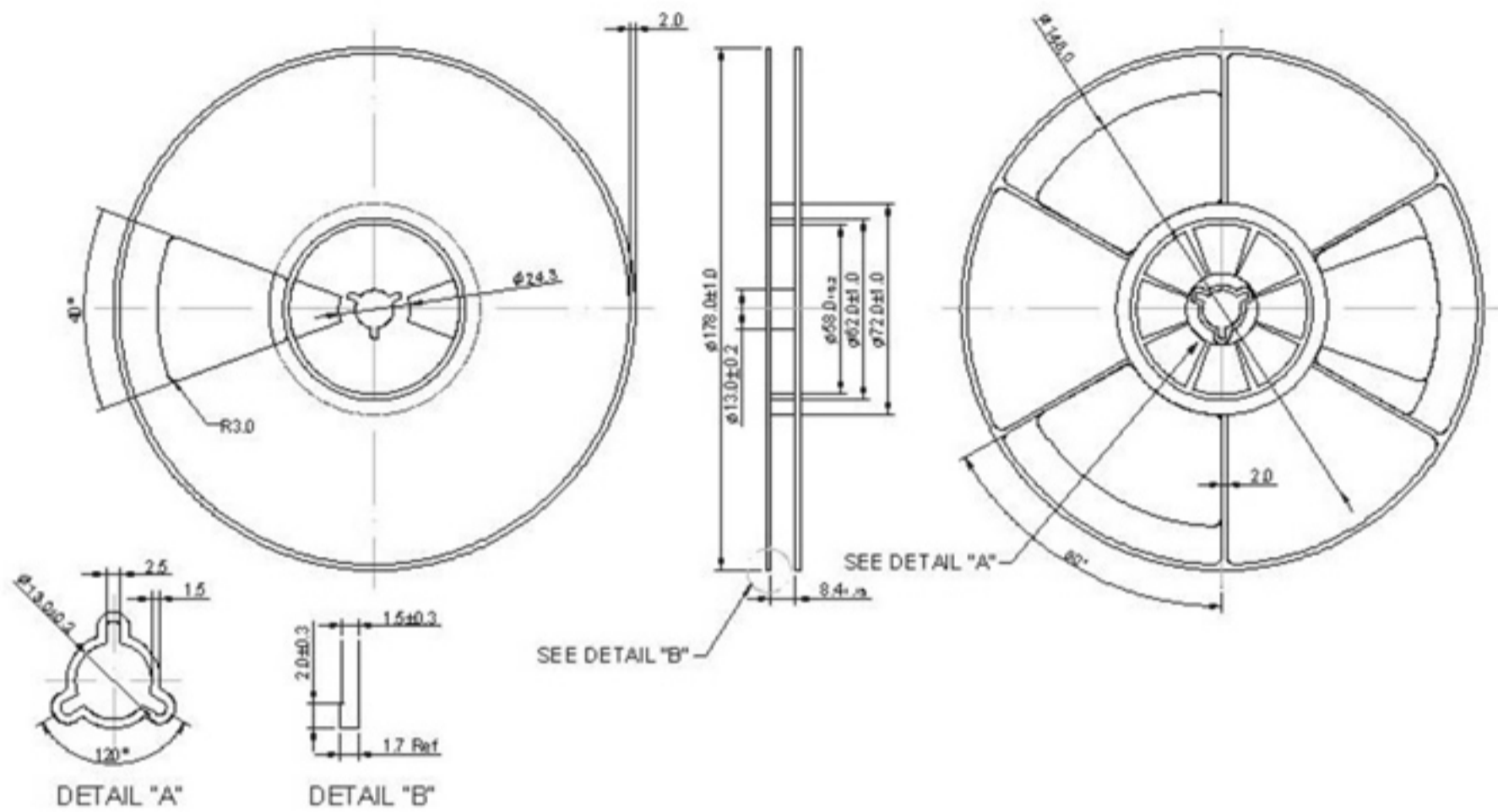

2. TAPE DIMENSION

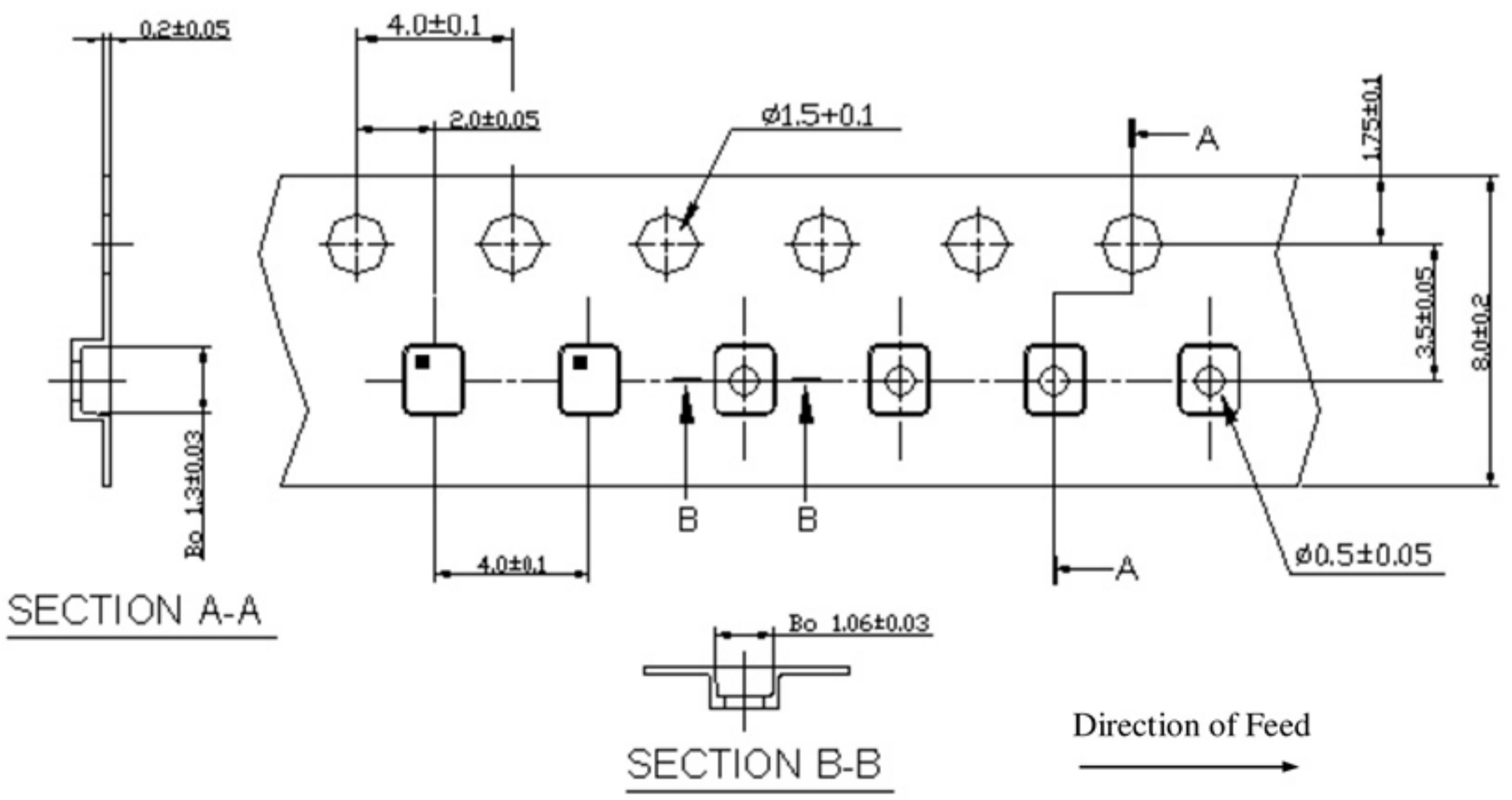

H. RECOMMENDED REFLOW PROFILE :

1. Preheating shall be fixed at 150~180°C for 60~90 seconds.
2. Ascending time to preheating temperature 150°C shall be 30 seconds min.
3. Heating shall be fixed at 220°C for 50~80 seconds and at 245~260°C peak (min. 10sec).
4. Time : 2 times.

