

SAW Filter 806 MHz SMD 1.1X0.9 mm (BW=30 MHz)

MODEL NO.:TA2041C

REV.2.0

A. MAXIMUM RATING:

1. Operating temperature range: -40 °C to +85 °C
2. Storage temperature range: -55 °C to +125 °C
3. Input power : 10dBm
4. Maximum DC Voltage: +/-5 V
5. Moisture Sensitivity Level: Level 3 (MSL 3)
6. ESD 100V(MM) 200V(HBM)

RoHS Compliant

Lead-free soldering

Electrostatic Sensitive Device (ESD)

B. ELECTRICAL CHARACTERISTICS:

Terminating source impedance : $Z_s = 50 \Omega$

Terminating load impedance : $Z_L = 50 \Omega$

Parameters Description		Unit	Min	Typ	Max	Remarks	
Insertion Loss	791~ 821MHz	Db(*1)	-	2.7	3.8		
Amplitude ripple	791~ 821MHz	dB	-	1.4	2.6		
VSWR	Input	791~ 821MHz	-	-	2.1	2.4	
	Output	791~ 821MHz	-	-	2.1	2.4	
Attenuation:							
832 ~ 862 MHz		dB	37	41	-		
1559 ~ 1607 MHz		dB	40	45	-		
1582 ~ 1642 MHz		dB	40	45	-		
2373 ~ 2463 MHz		dB	30	37	-		
2400 ~ 2500 MHz		dB	30	37	-		
3164 ~ 3284 MHz		dB	25	34	-		
3955 ~ 4105 MHz		dB	20	31	-		
4746 ~ 4926 MHz		dB	20	29	-		
4900 ~ 5950 MHz		dB	20	26	-		
5537 ~ 5747 MHz		dB	20	27	-		
6328 ~ 6568 MHz		dB	20	25	-		
7119 ~ 7389 MHz		dB	15	23	-		
Input impedance		Ω	50			single-ended	
Output impedance		Ω	50			single-ended	

(*1) Specification of insertion loss excludes loss that comes from the test board.

C. FREQUENCY CHARACTERISTICS:

Passband

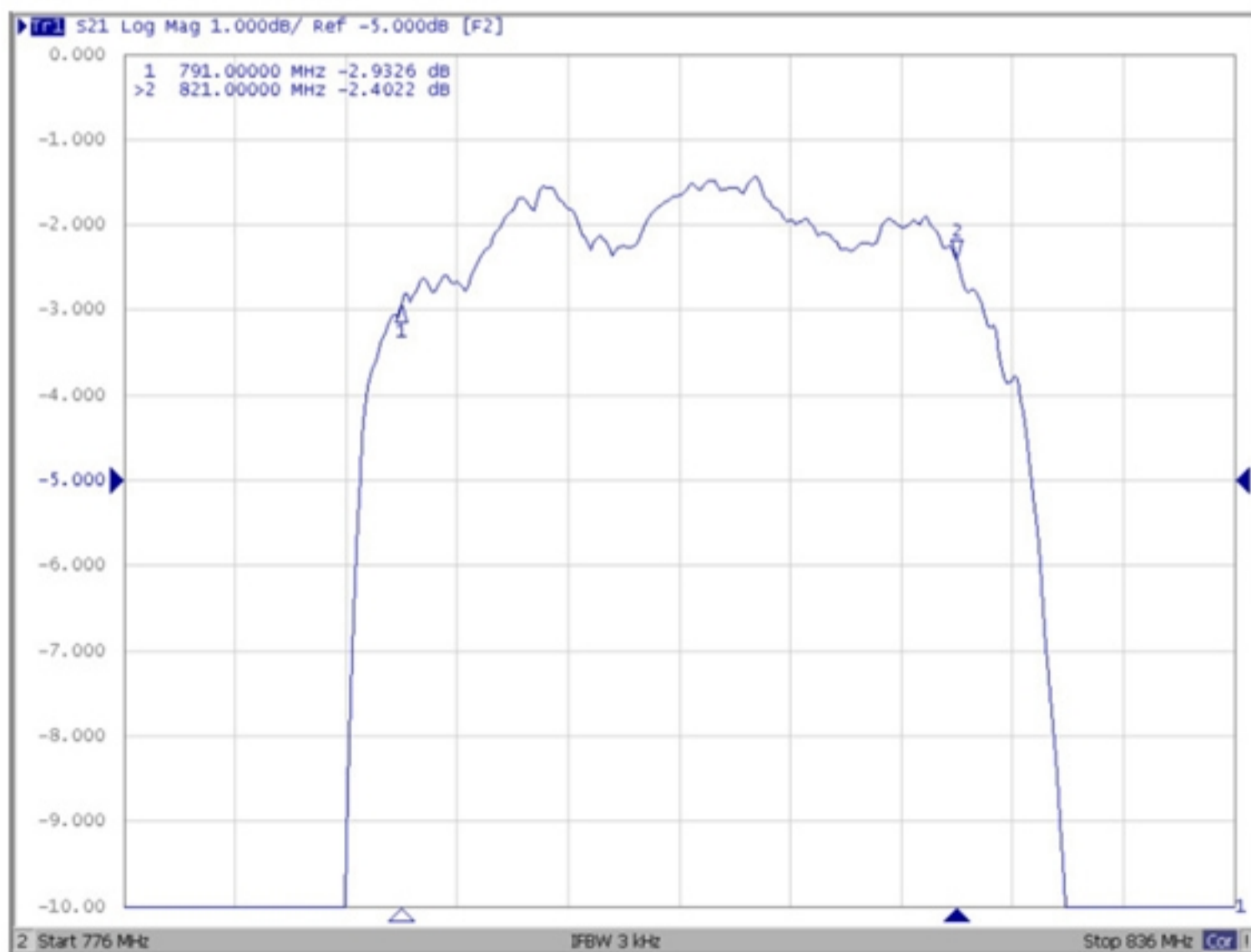
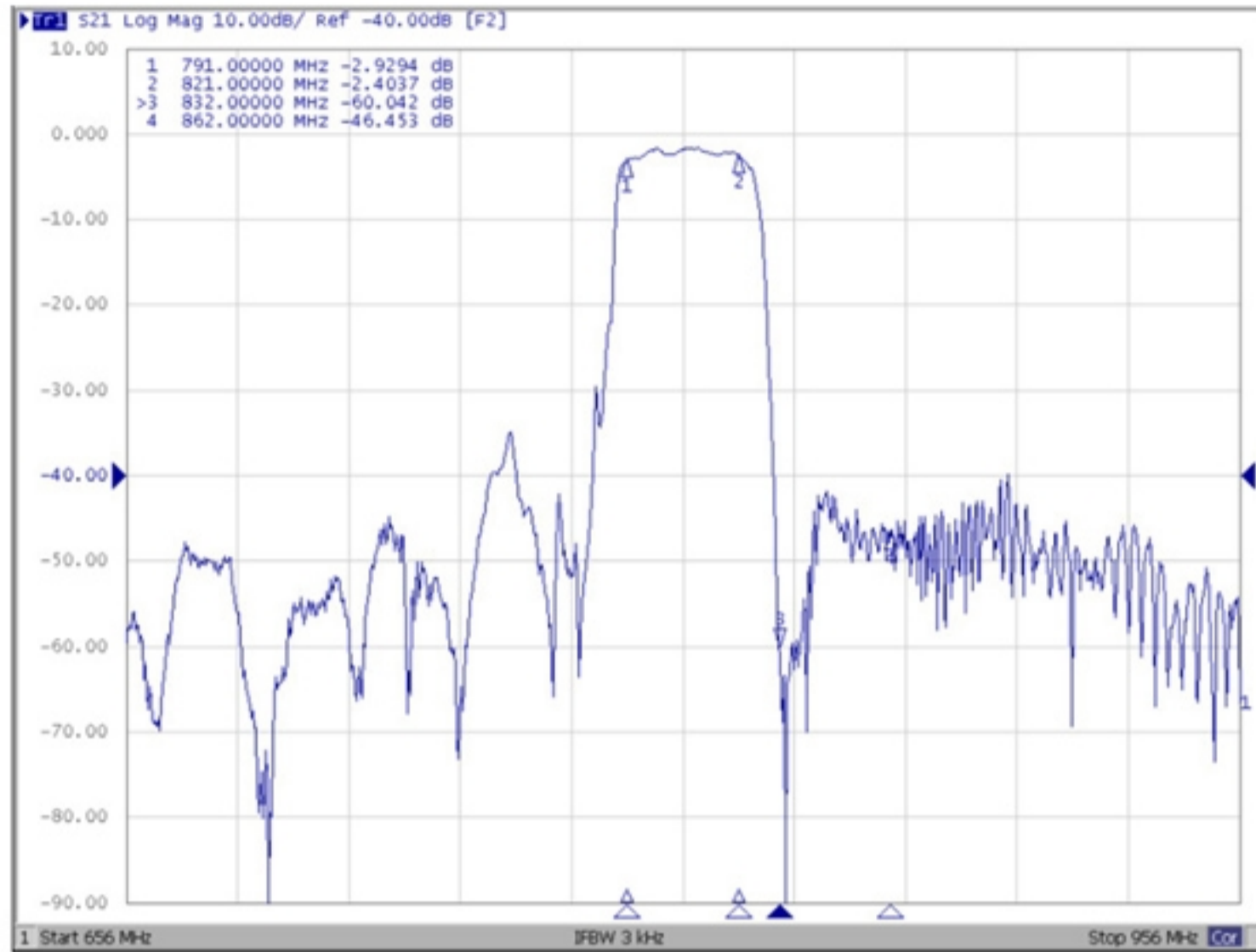

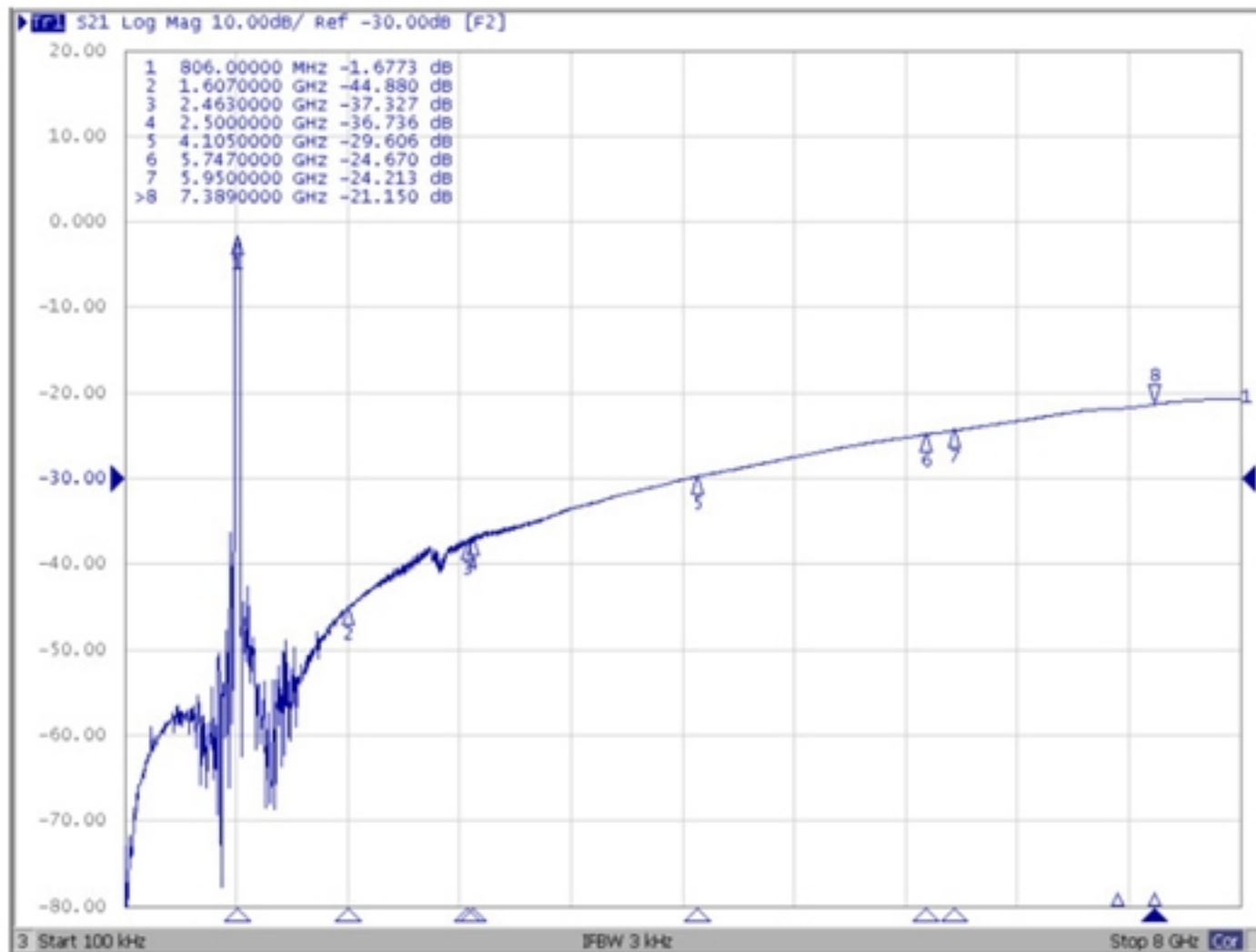

Reflection functions :

S11 VSWR

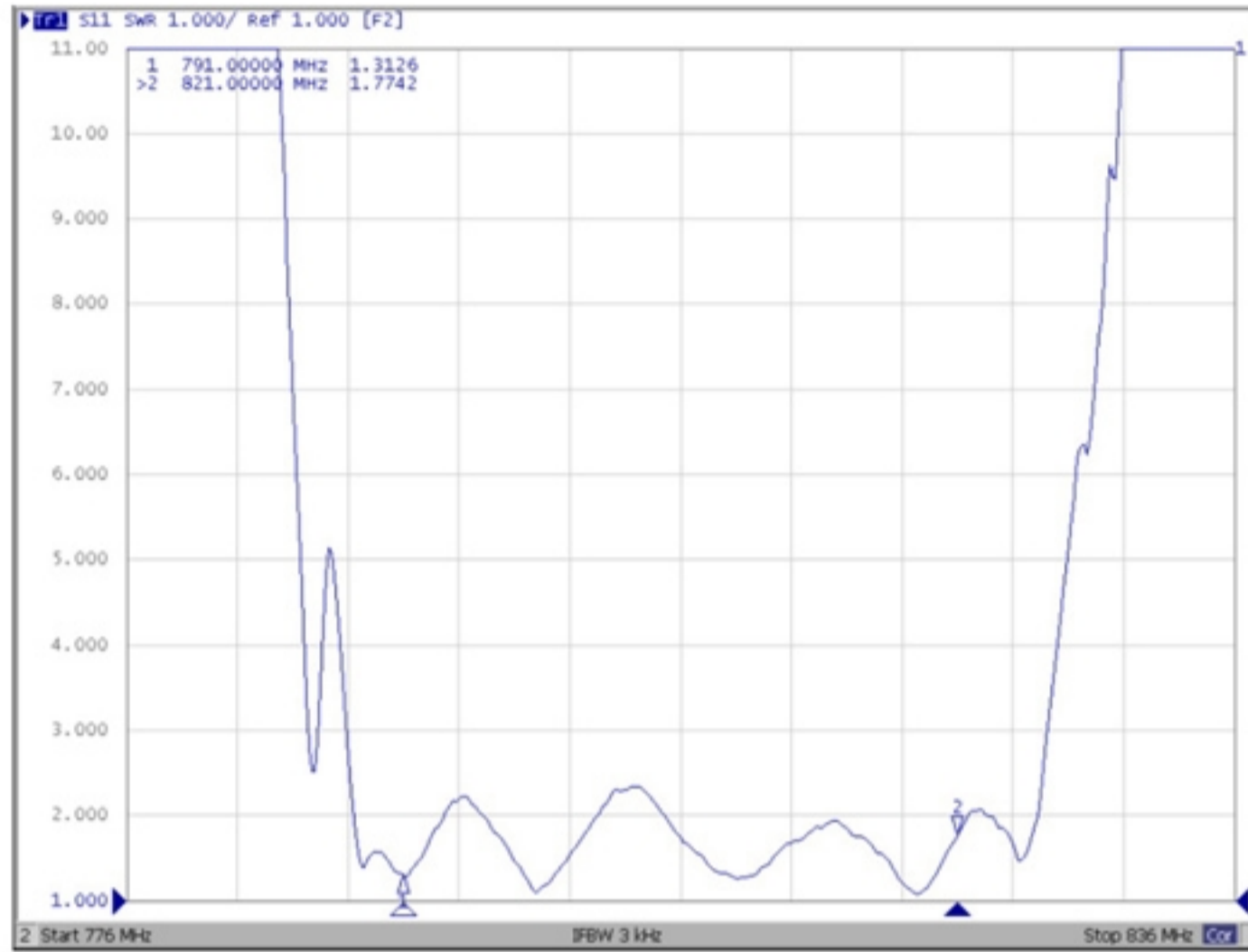

S22 VSWR

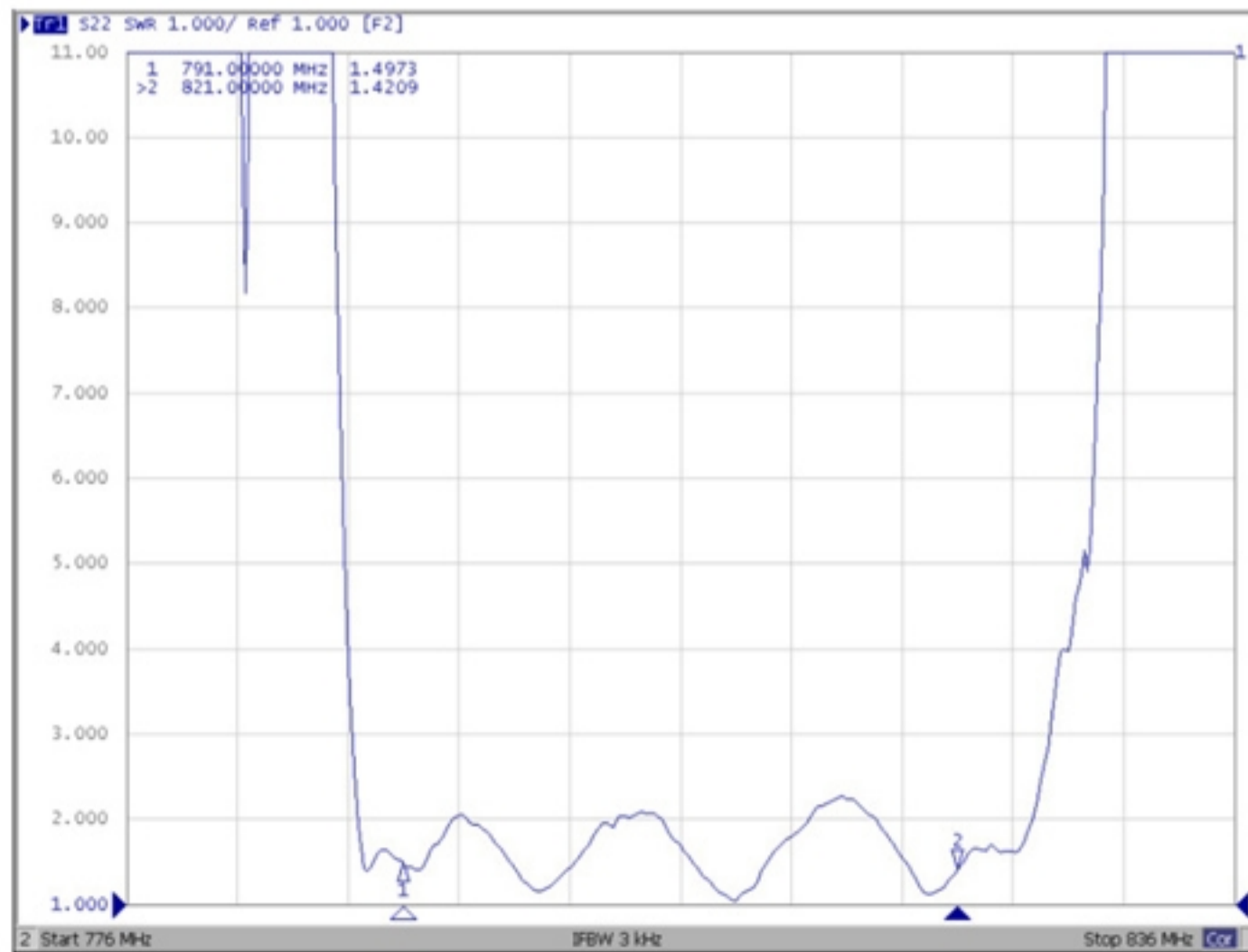

S11 Smith Chart

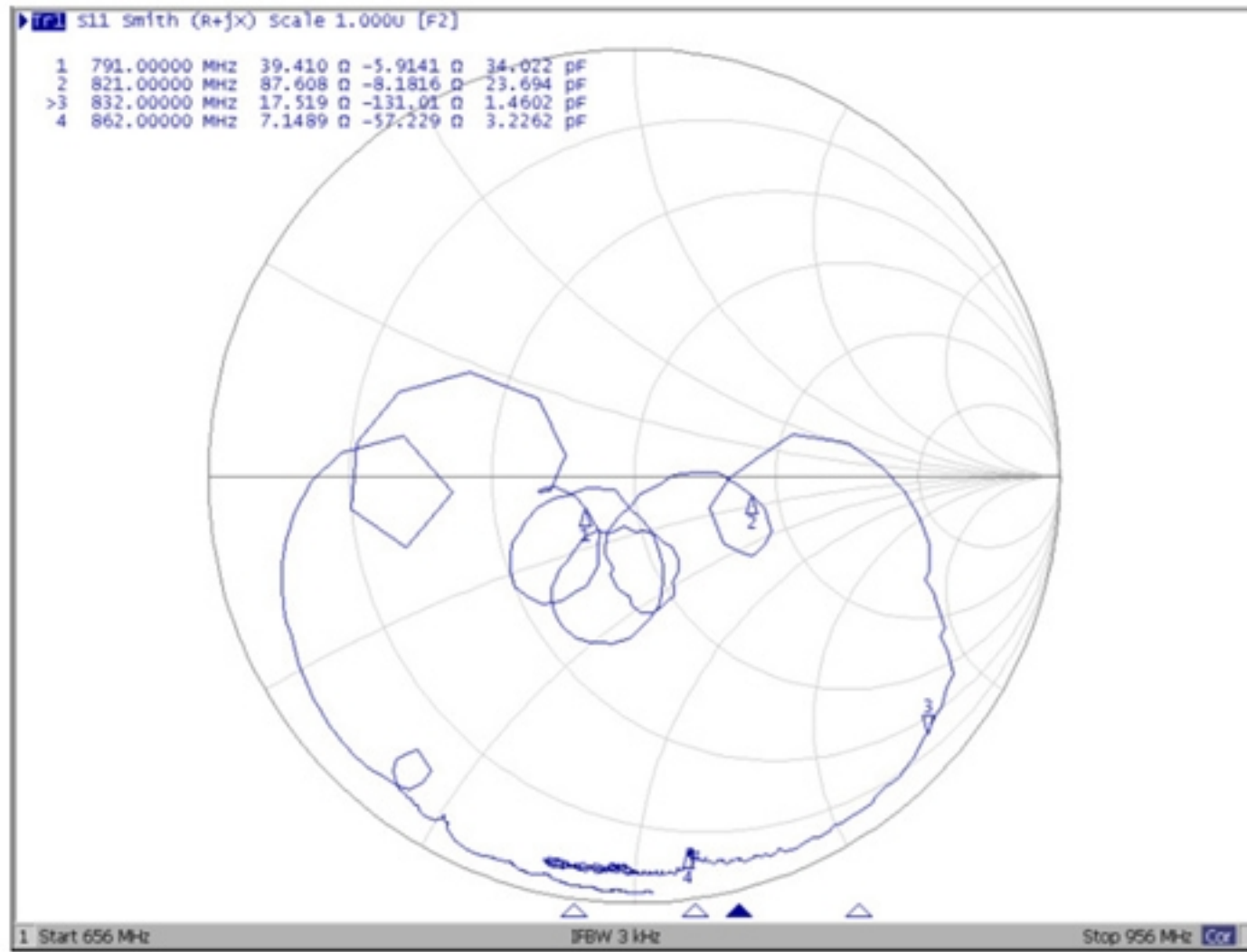

S22 Smith Chart

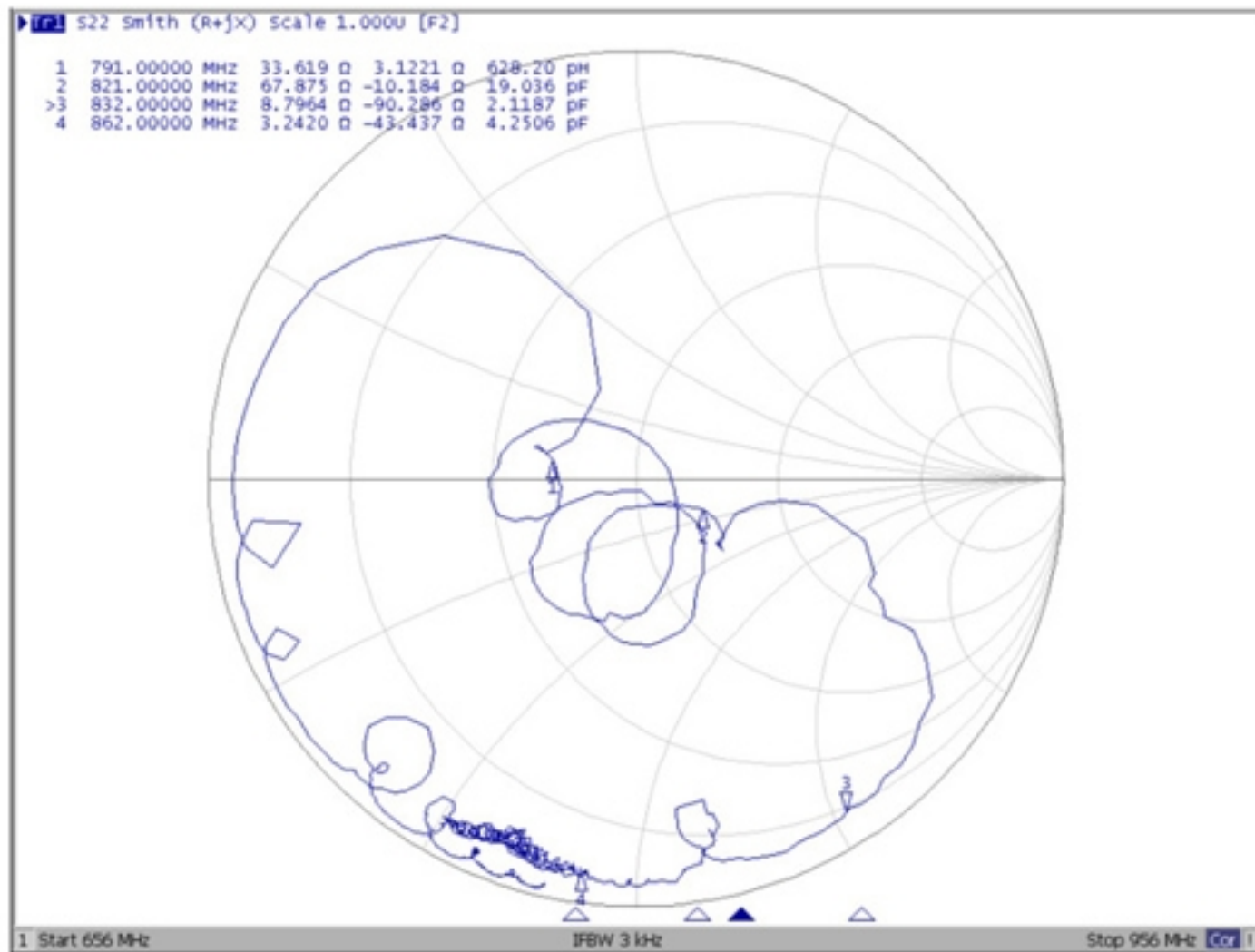

D. OUTLINE DRAWIN:

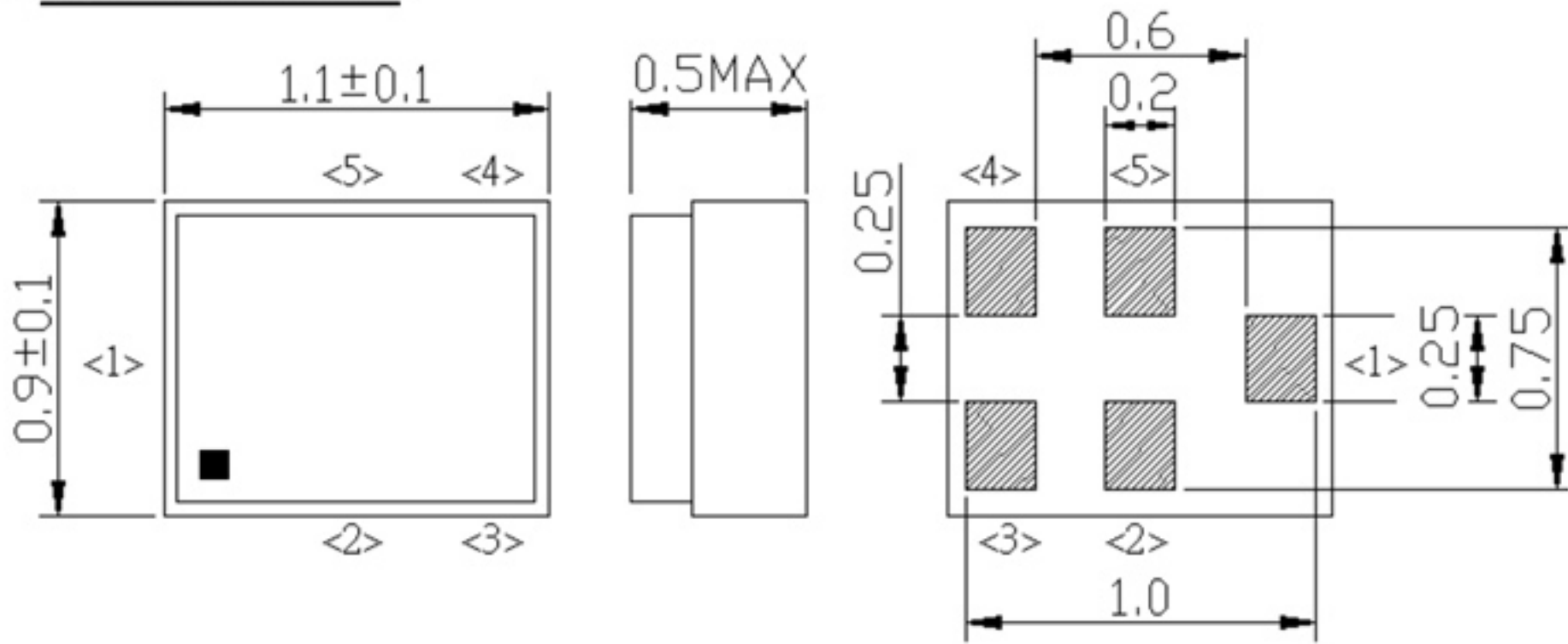

Unit: mm

Not Specified Tolerance : +/-0.1 mm

Pin Configuration

Pin No.	Symbol	Function
1	IN	Single-ended pin
2	GND	Ground
3	GND	Ground
4	OUT	Single-ended pin
5	GND	Ground

Top View (Mass Production):



△ : Date Code

□ : Lot No. (Indicated by 0~9 or A to Z and a to z, except I, O, i, o and l)

Date Code: Follow below table. (4-year cycle)

Year	Jan	Feb	Mar	Apr	May	Jun	Jul	Aug	Sep	Oct	Nov	Dec
2019 / 2023	a	b	c	d	e	f	g	h	j	k	l	m
2020 / 2024	n	p	q	r	s	t	u	v	w	x	y	z
2021 / 2025	A	B	C	D	E	F	G	H	J	K	L	M
2022 / 2026	N	P	Q	R	S	T	U	V	W	X	Y	Z

E.Evaluation Circuit

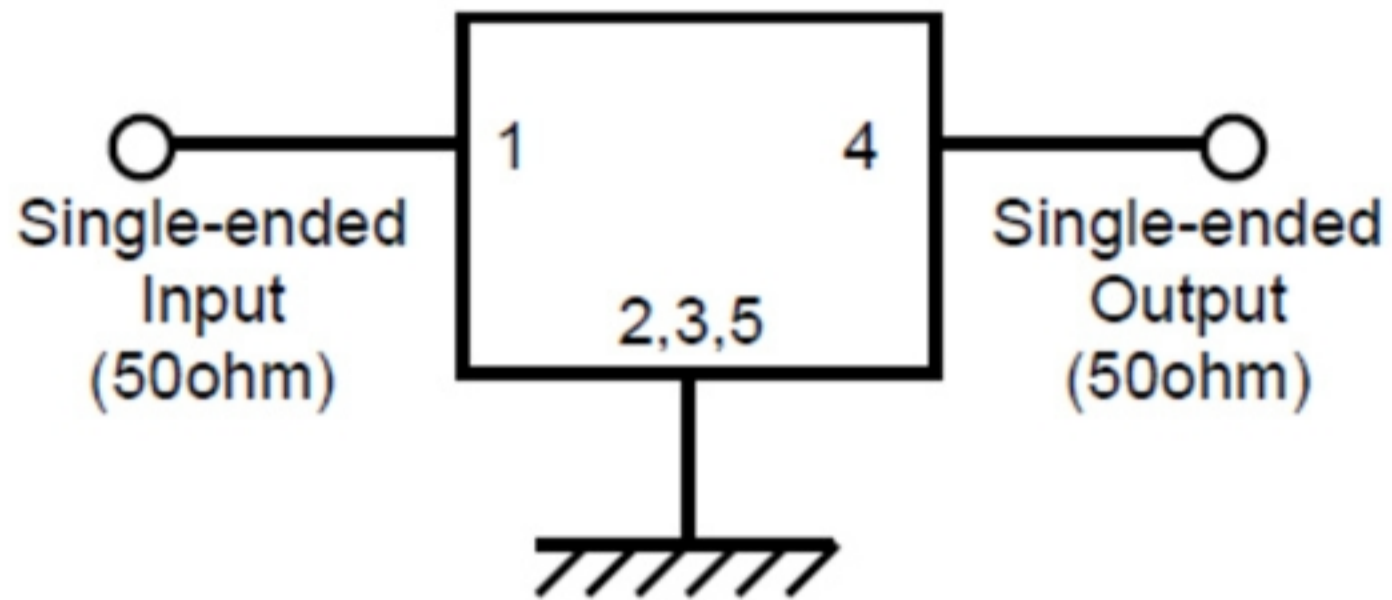

F. PCB Footprint :

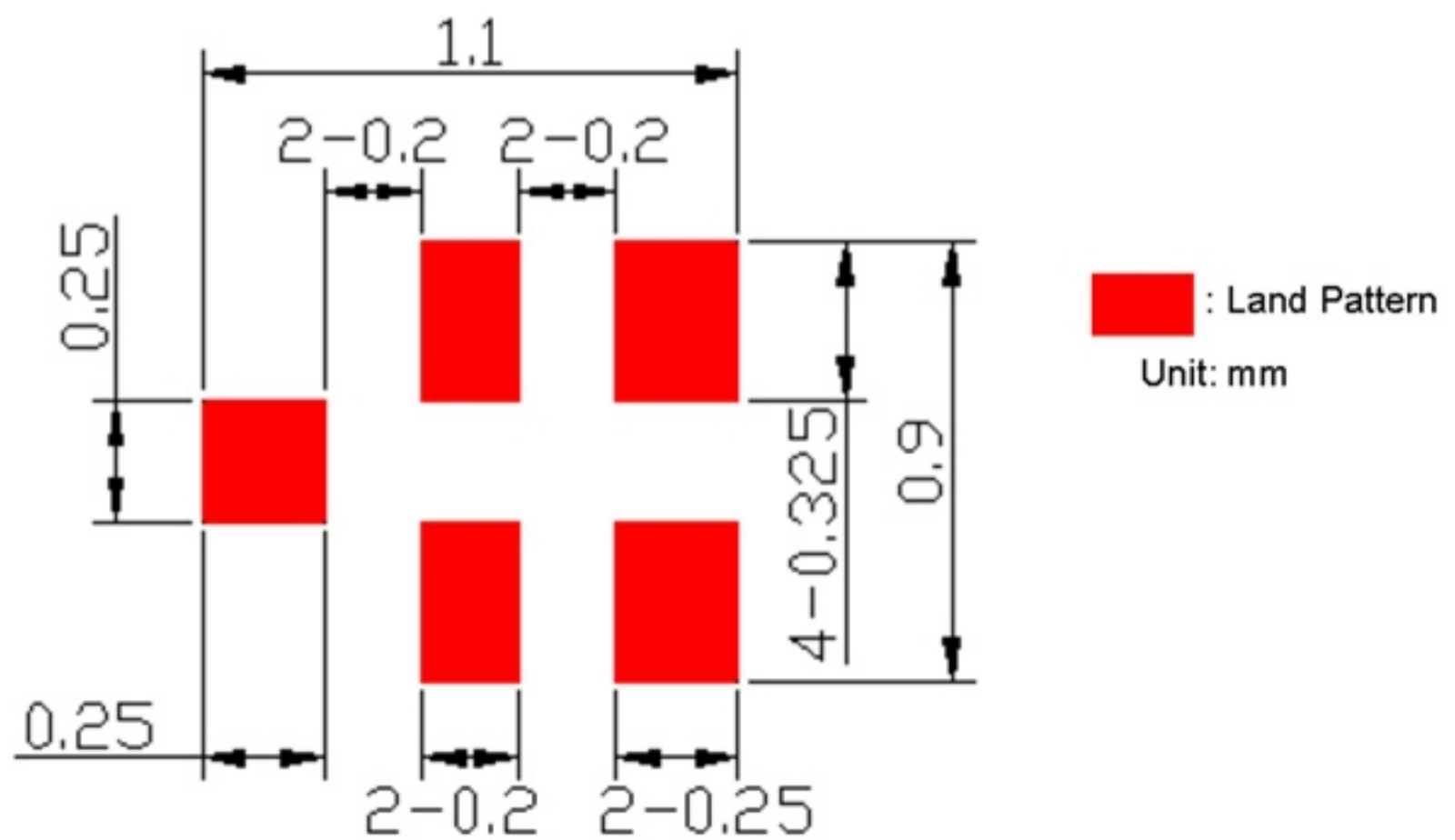

G. PACKING:

1. REEL DIMENSION

(Please refer to FR-75D10 for packing quantity)

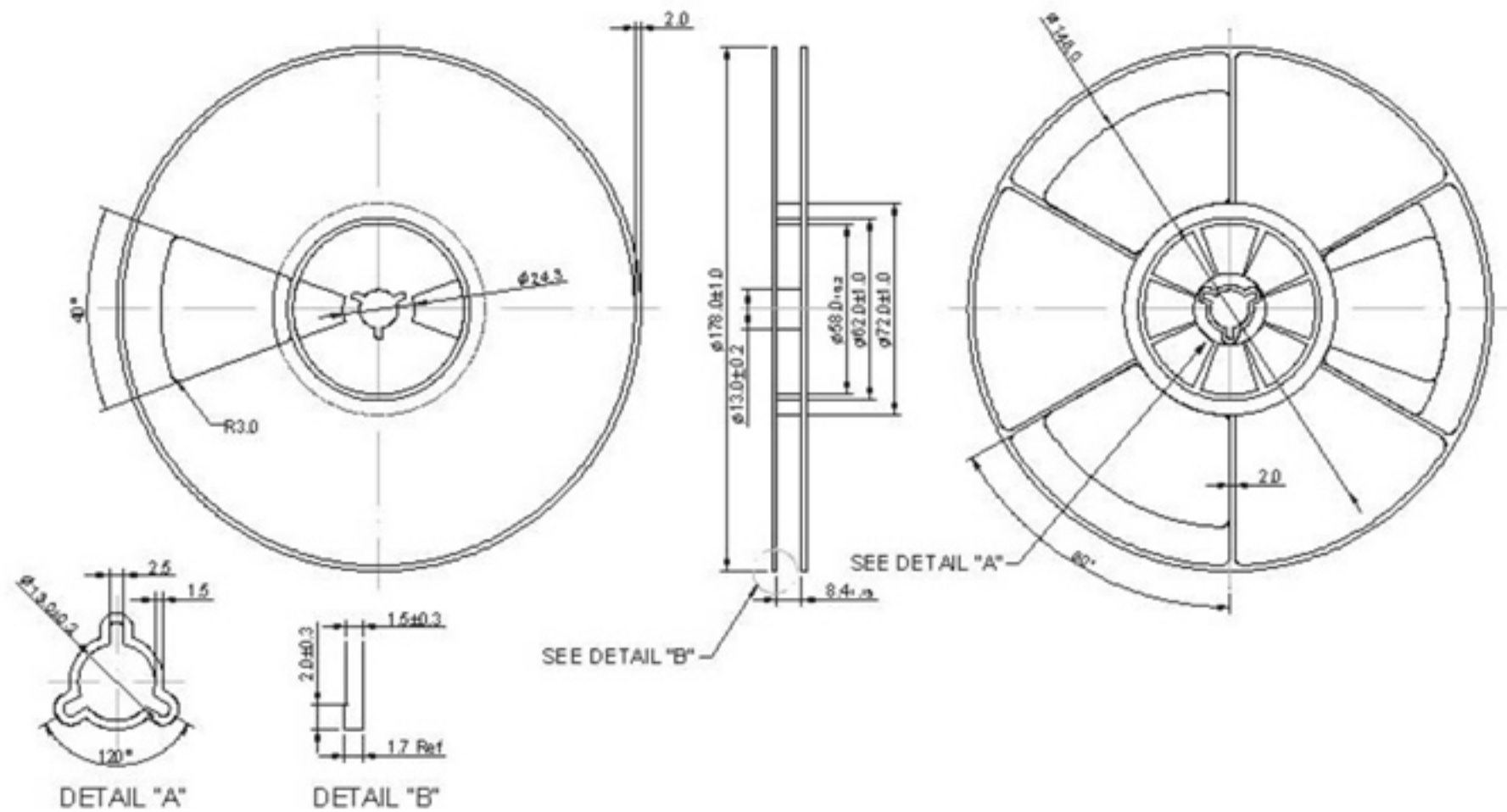

2. TAPE DIMENSION

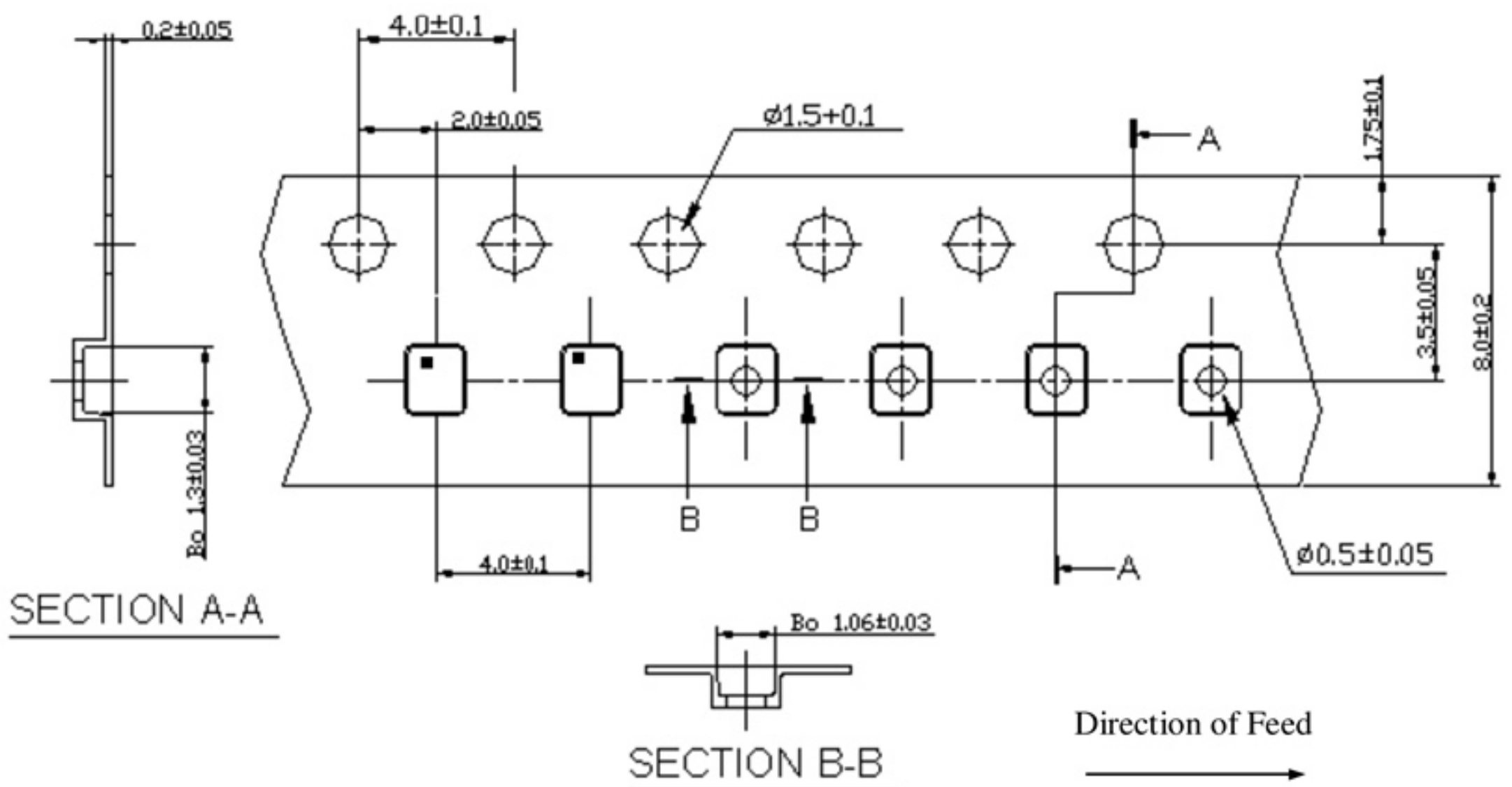

H . RECOMMENDED REFLOW PROFILE :

1. Preheating shall be fixed at 150~180°C for 60~90 seconds.
2. Ascending time to preheating temperature 150°C shall be 30 seconds min.
3. Heating shall be fixed at 220°C for 50~80 seconds and at 245~260°C peak (min. 10sec).
4. Time : 2 times.

