

SAW Filter 788 MHz

MODEL NO.:TA1898AC

REV. NO.:2.0

A. MAXIMUM RATING:

1. Input Power Level: 15 dBm
2. DC Voltage : +/-5 V
3. Operating Temperature: -30 °C to +85 °C
4. Storage Temperature: -40 °C to +85 °C
5. Moisture Sensitive Level: Level 1 (MSL1)
6. ESD: 100 V(MM), 200 V(HBM)

RoHS Compliant

Lead-free soldering

Electrostatic Sensitive Device (**ESD**)

B. ELECTRICAL CHARACTERISTICS:

Terminating source impedance: $Z_s = 50 \Omega$

Terminating load impedance: $Z_L = 50 \Omega$

Item	Unit	Min.	Typ.	Max.
Center Frequency F_c	MHz	-	788	-
Insertion Loss (773~803 MHz) IL	dB	-	2.0	2.8
Amplitude Ripple (773~803 MHz)	dB _{p-p}	-	1.0	2.1
VSWR (773~803 MHz)	-	-	2.2	2.5
Attenuation (Reference level from 0 dB)				
703 ~ 718 MHz	dB	46	60	-
718 ~ 748 MHz	dB	46	52	-
1546 ~ 1606 MHz	dB	40	49	-
1559 ~ 1606 MHz	dB	40	49	-
2319 ~ 2409 MHz	dB	35	43	-
2400 ~ 2500 MHz	dB	35	43	-
3092 ~ 3212 MHz	dB	30	41	-
3865 ~ 4015 MHz	dB	30	39	-
4638 ~ 4818 MHz	dB	30	38	-
4900 ~ 5950 MHz	dB	30	38	-
5411 ~ 5621 MHz	dB	30	38	-
6184 ~ 6424 MHz	dB	30	39	-
6957 ~ 7227 MHz	dB	30	38	-

C. FREQUENCY CHARACTERISTICS:

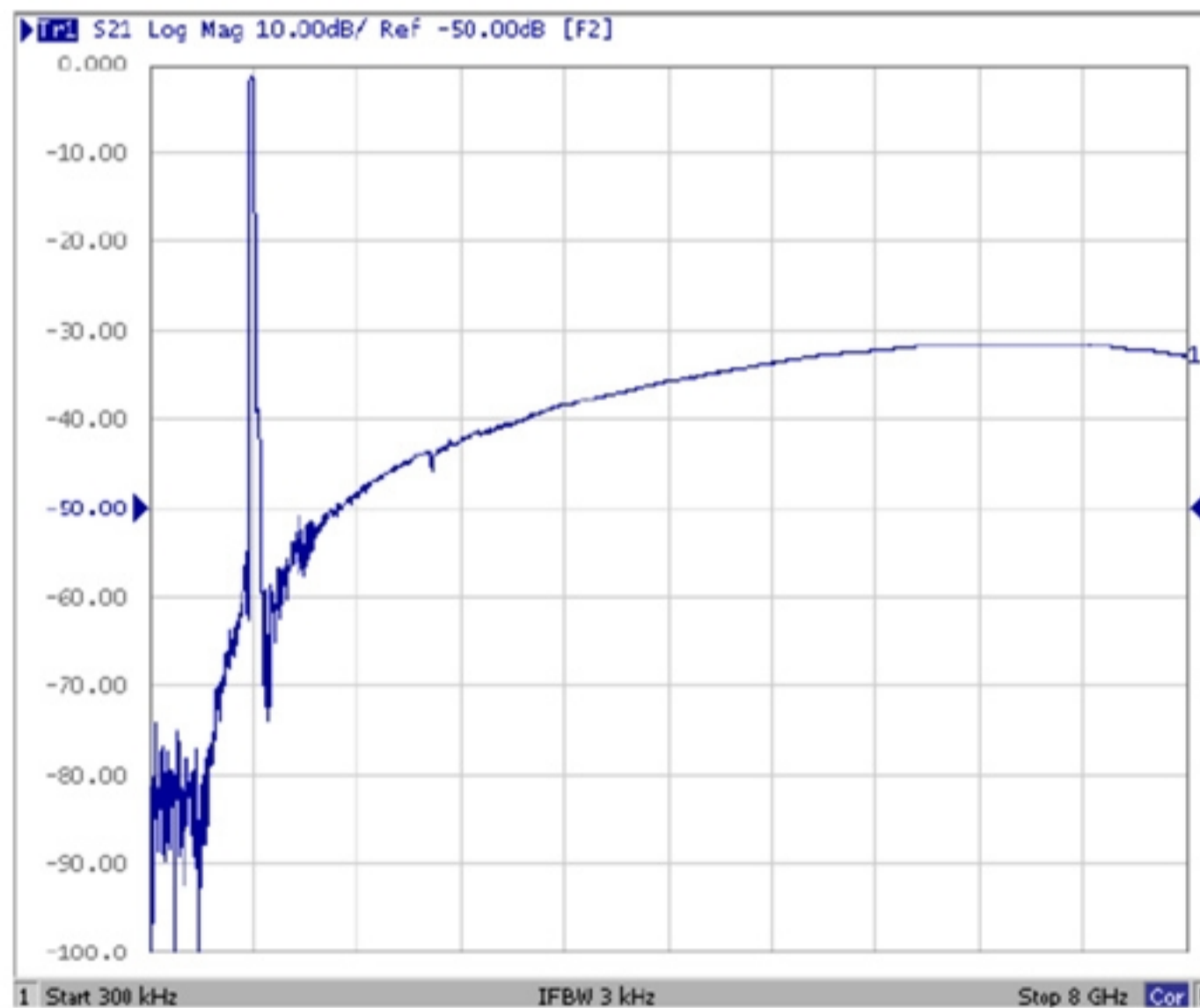
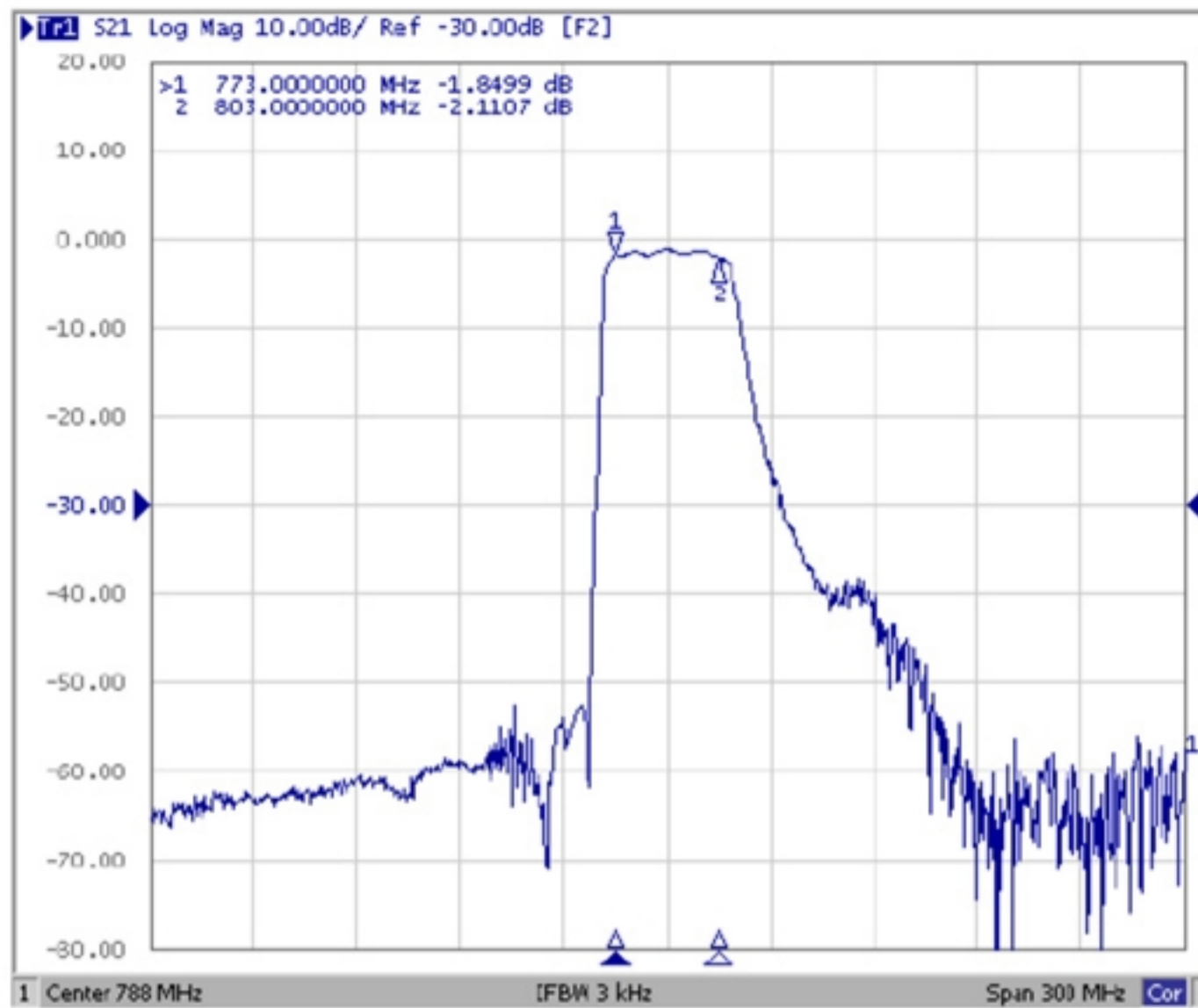

Reflection Functions:

VSWR

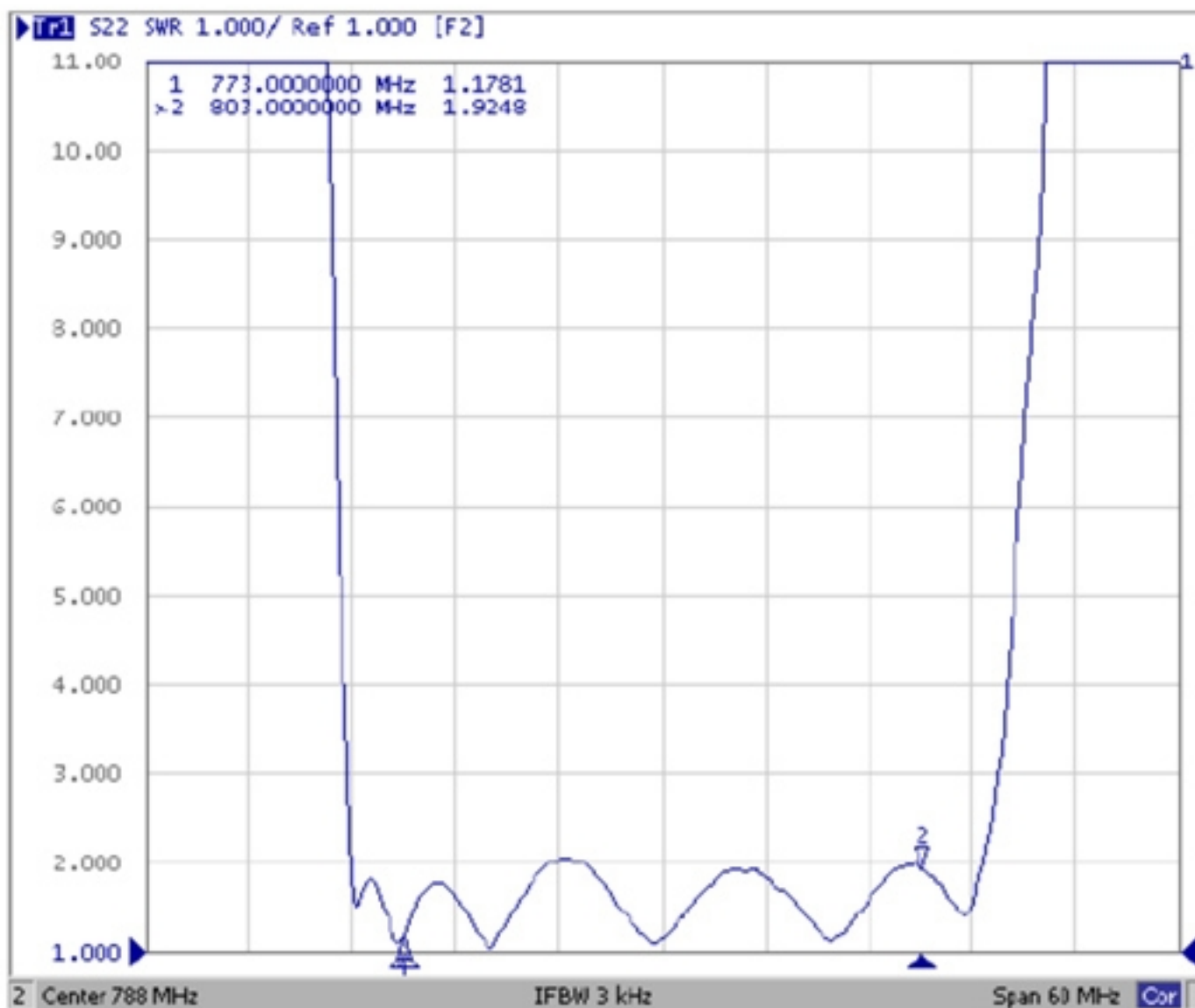
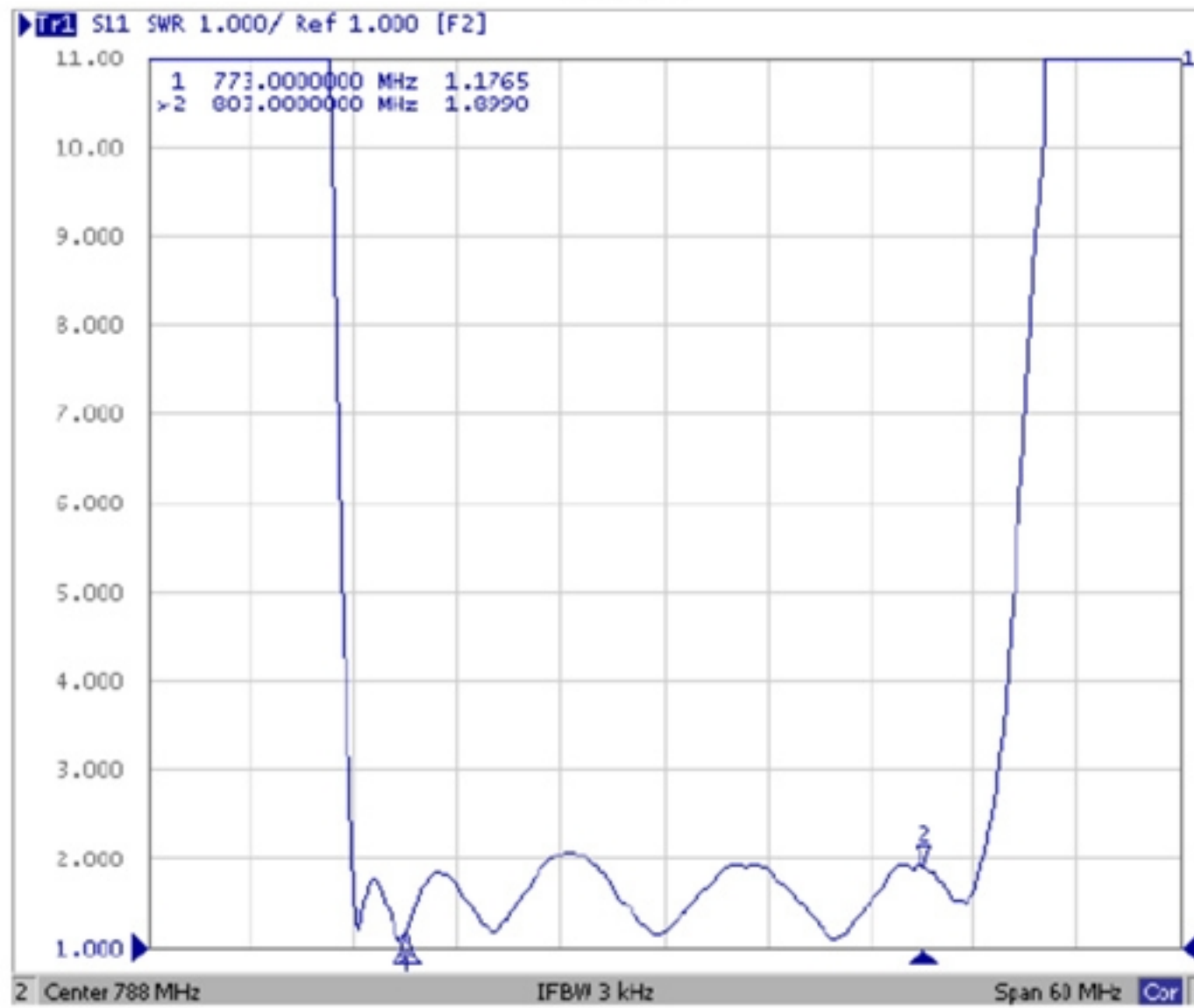

Smith Chart

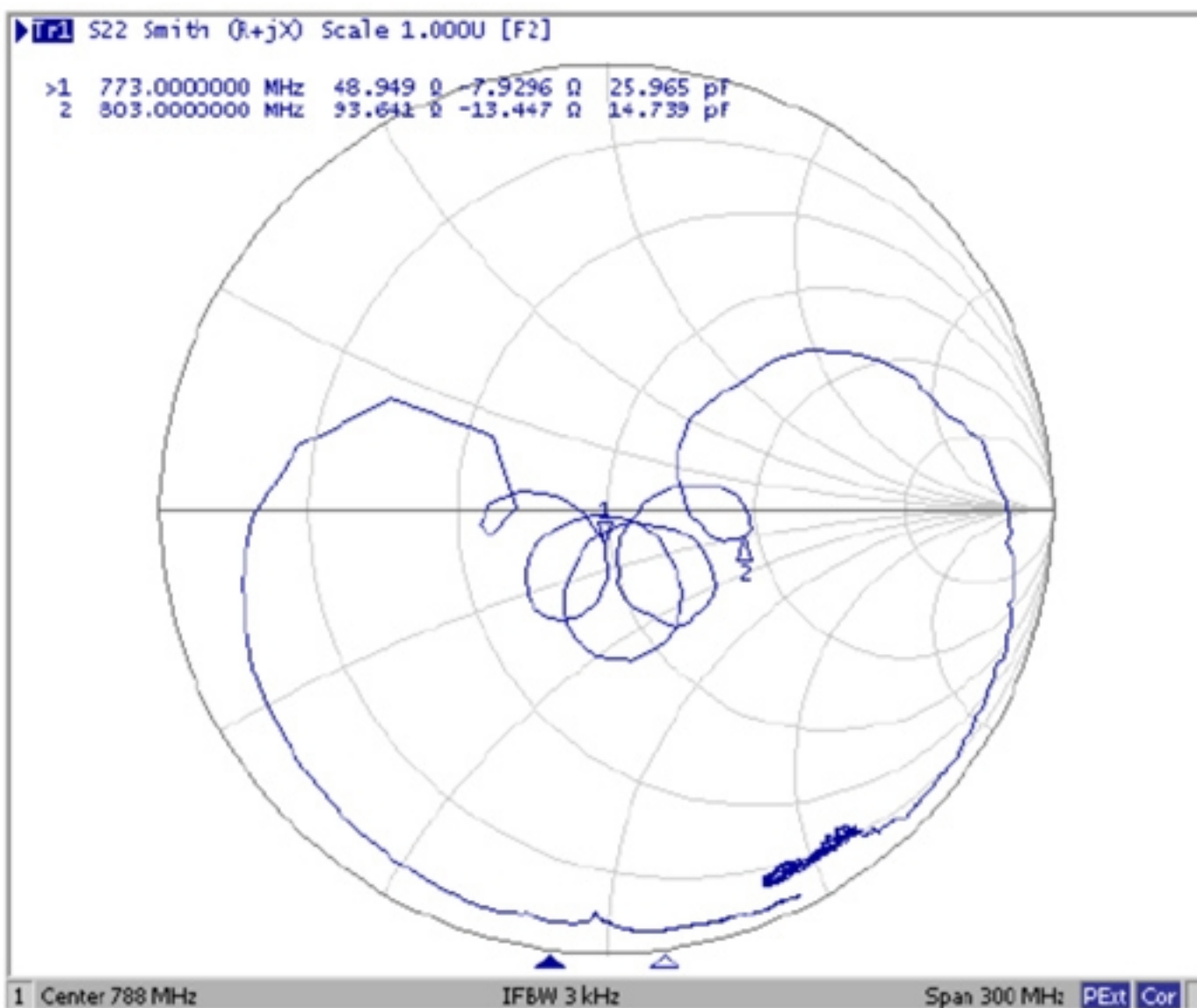
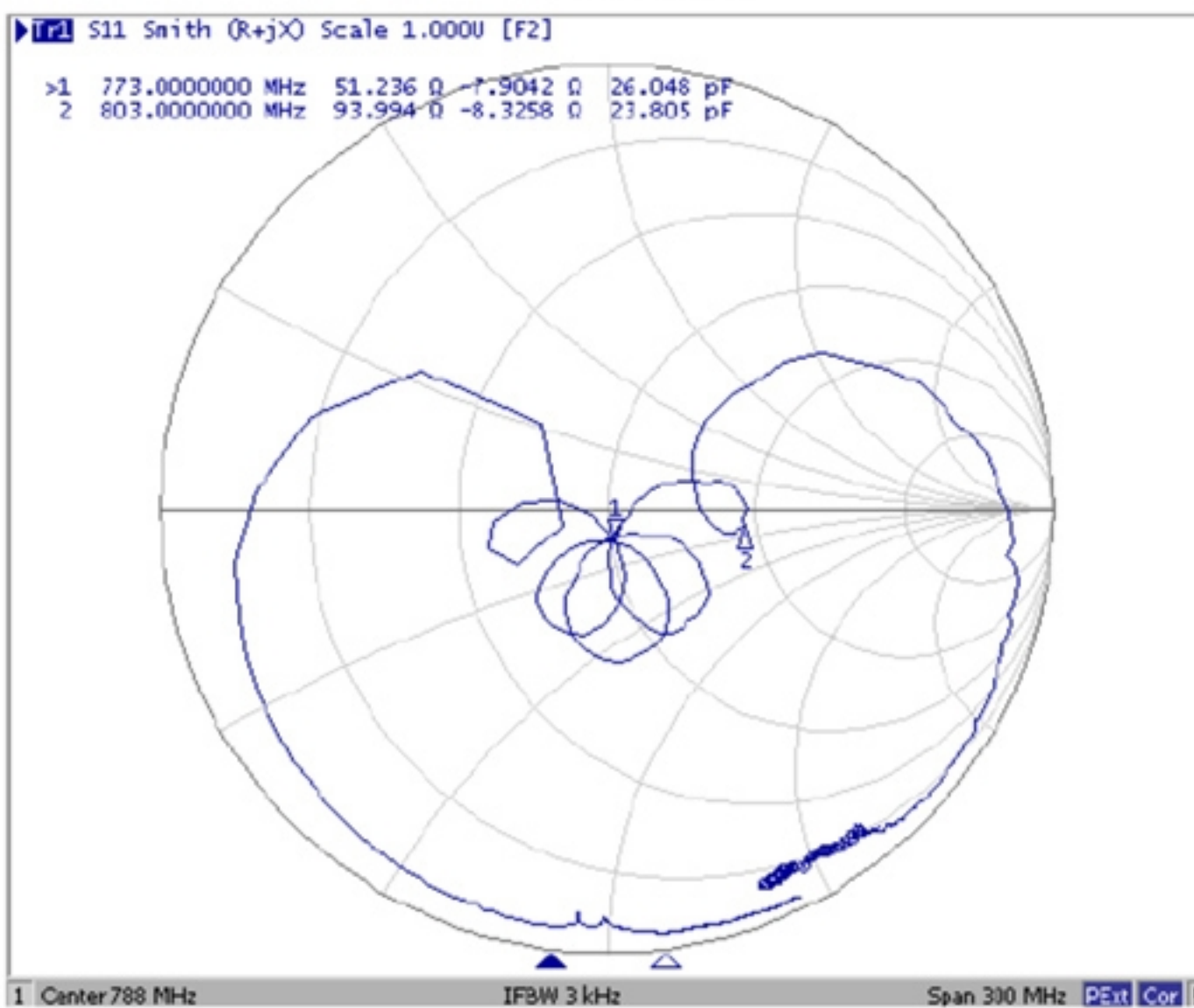

D. MEASUREMENT CIRCUIT:

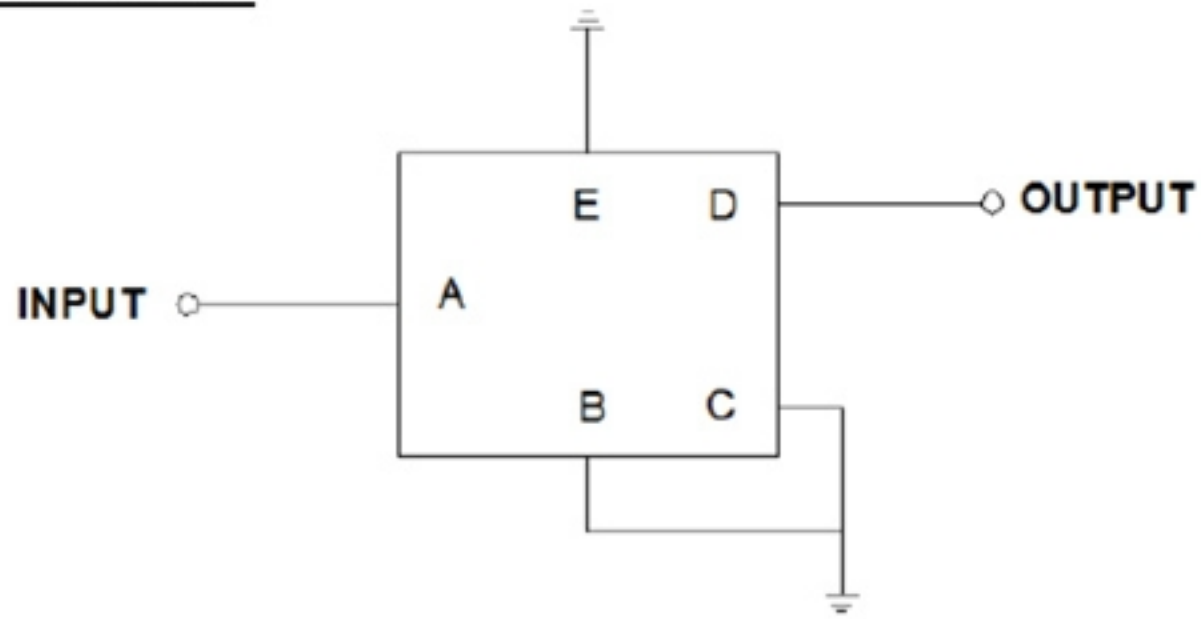

Source & Load Impedance: 50 Ω

E. PCB Footprint:

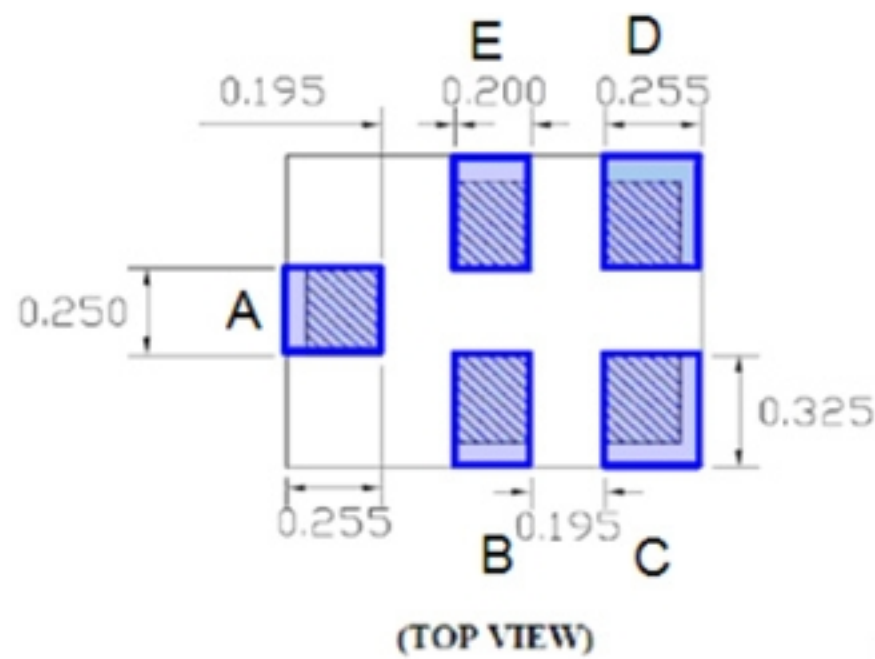

F. OUTLINE DRAWING:

Device size: 1.1typ. x 0.9typ. x 0.5max.

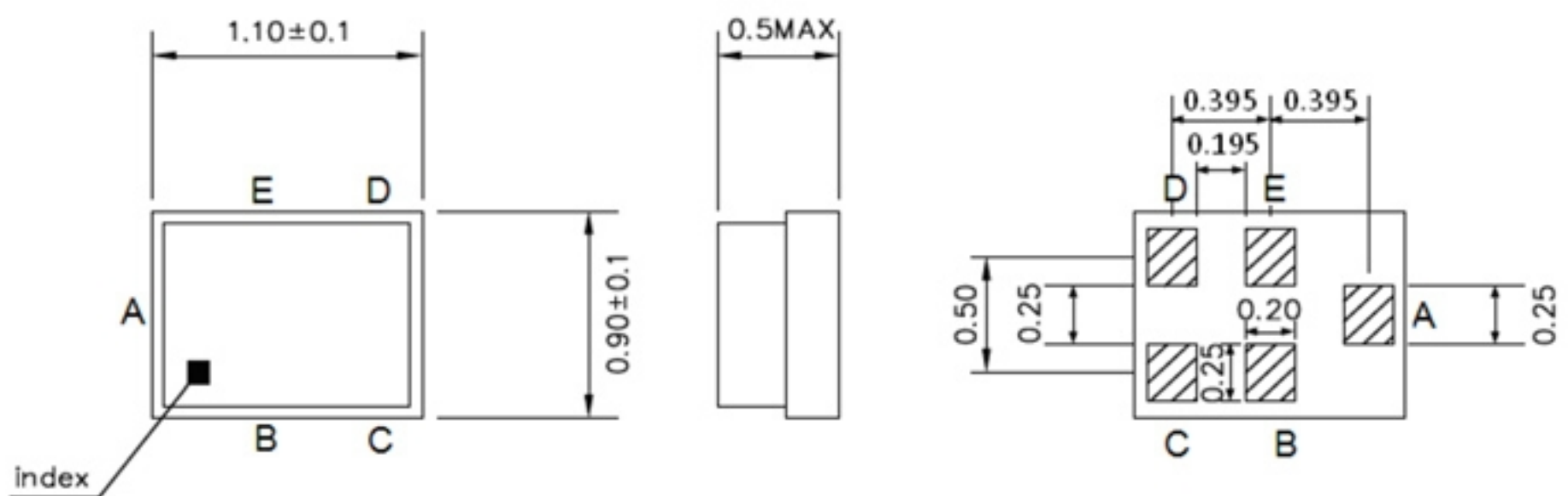

Unit : mm

Pin Configuration

Pin No.	Symbol	Function
A	IN	Unbalanced pin
B	GND	Ground
C	GND	Ground
D	OUT	Unbalanced pin
E	GND	Ground

Top View (Sample Production):



Top View (Mass Production):

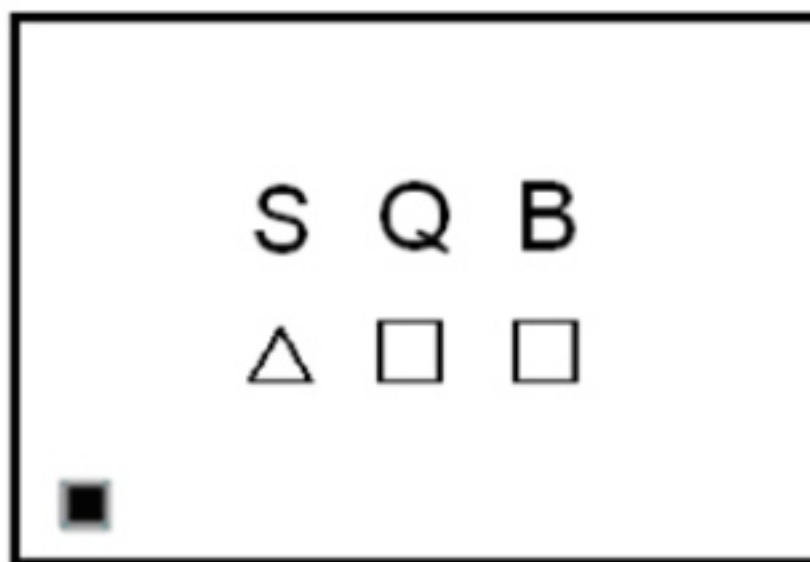

△ : **Date Code**

□ : **Lot No. (Indicated by 0~9 or A to Z and a to z, except I, O, i, o and l)**

Date Code:

Year	Jan.	Feb.	Mar.	Apr.	May	Jun.	Jul.	Aug.	Sep.	Oct.	Nov.	Dec.
2017	A	B	C	∅	E	F	G	H	J	K	L	M
2018	N	P	Q	R	S	T	U	∇	W	X	Y	Z
2019	a	b	c	d	e	f	g	h	j	k	l	m
2020	n	p	q	r	s	t	u	v	w	x	y	z

G. PACKING: (Ref: WI-75M03)

1. REEL DIMENSION

(Please refer to FR-75D10 for packing quantity)

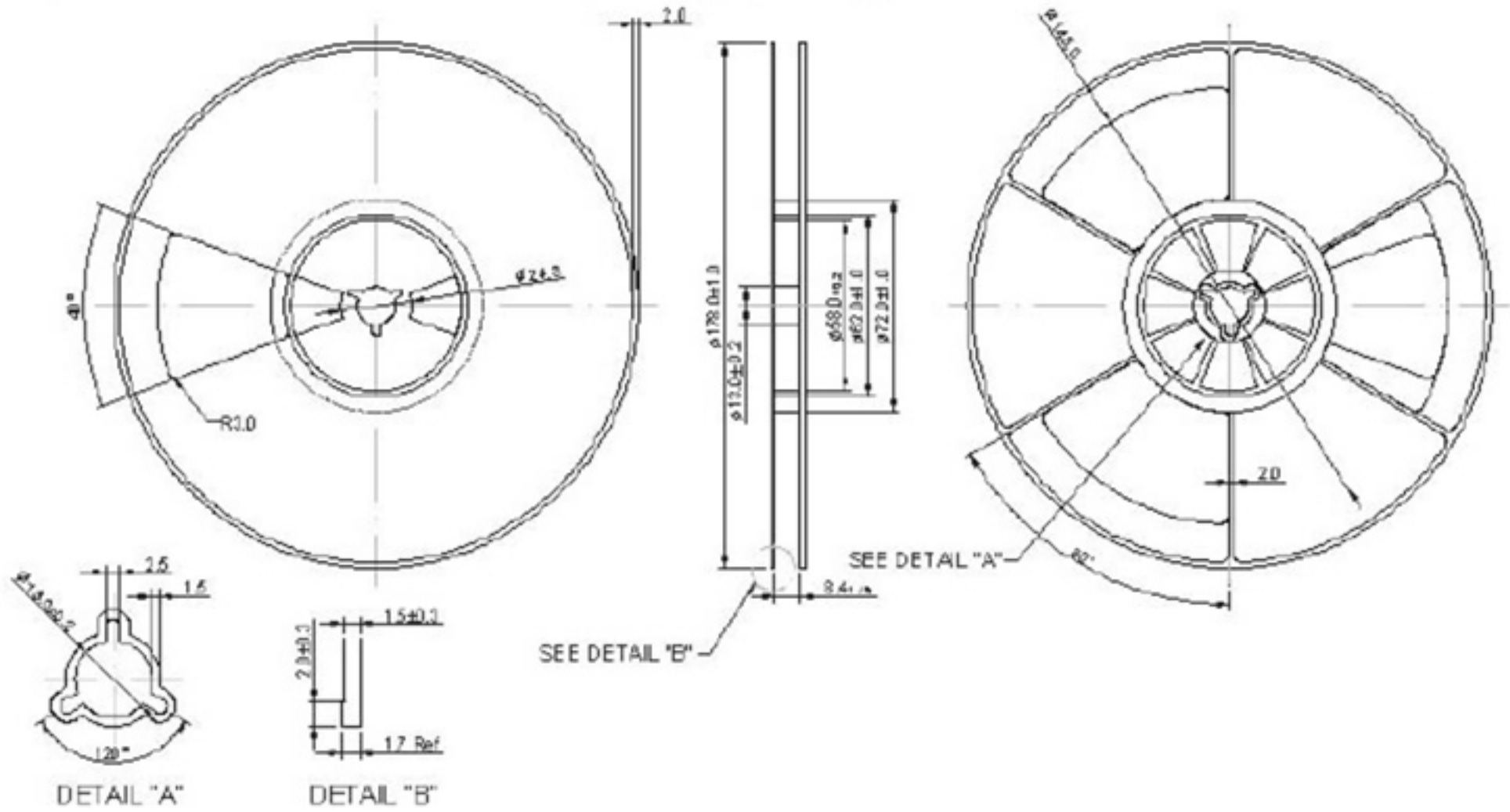

2. TAPE DIMENSION

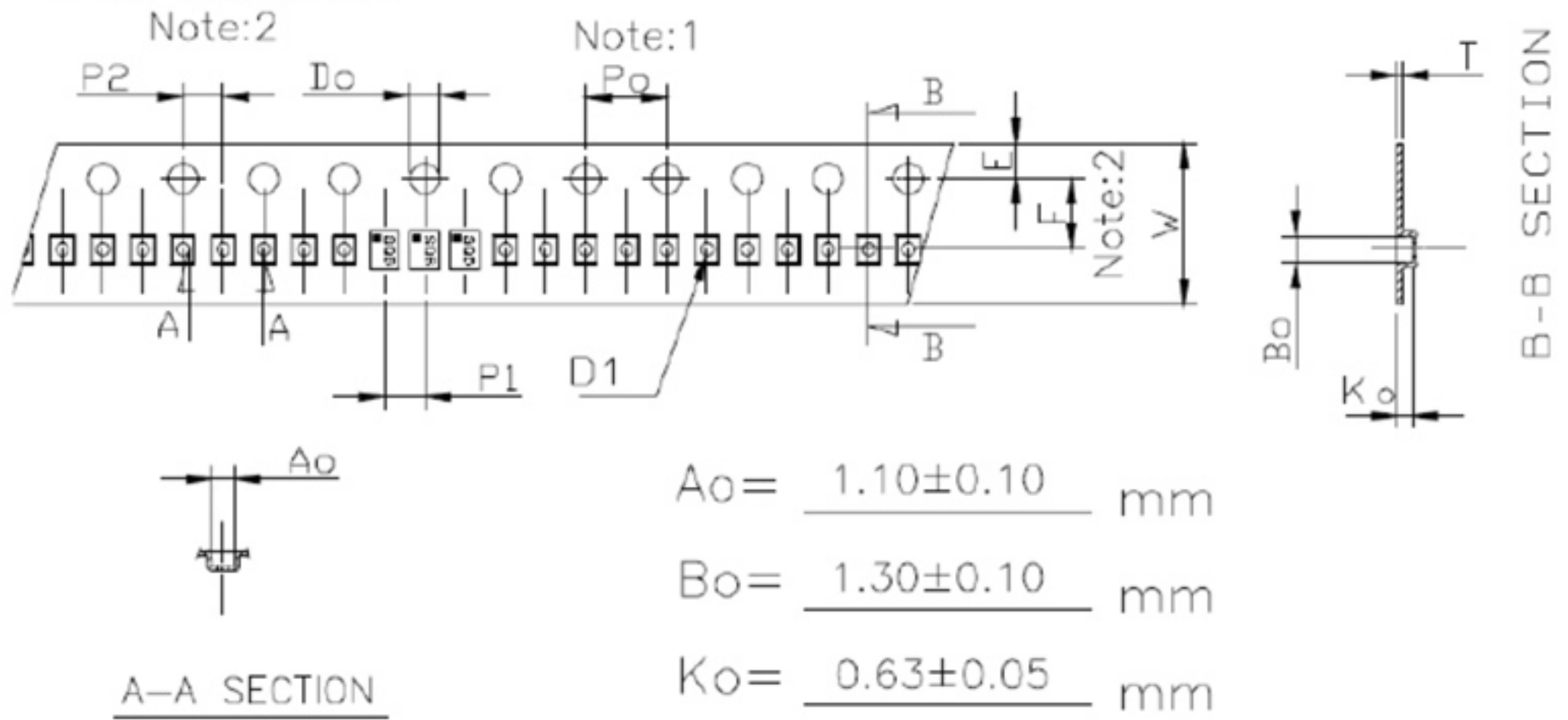

H. Recommended Reflow Profile:

1. Preheating shall be fixed at 150~180°C for 60~90 seconds.
2. Ascending time to preheating temperature 150°C shall be 30 seconds min.
3. Heating shall be fixed at 220°C for 50~80 seconds and at 260°C +0/-5°C peak (20~40sec).
4. Time: 2 times.

