

A. MAXIMUM RATING:

1. Input Power Level: 20 dBm
2. DC Voltage : 0V
3. Operating Temperature: -40 °C to +105 °C
4. Storage Temperature: -40 °C to +105 °C
5. Moisture Sensitive Level: Level 3 (MSL3)



Electrostatic Sensitive Device (ESD)

B. ELECTRICAL CHARACTERISTICS:

Terminating source impedance: $Z_S = 50 \Omega$

Terminating load impedance: $Z_L = 50 \Omega$

Item	Unit	Min.	Typ.	Max.
Center Frequency	MHz	-	1238	-
Insertion Loss (1197 ~ 1279 MHz)	dB	-	2.6	3.5
Amplitude Ripple (25 MHz Window)	dB	-	0.6	1.0
Attenuation (reference level from 0 dB)				
500 ~ 1100 MHz	dB	25	32	-
1370 ~ 2500 MHz	dB	25	30	-

C. OUTLINE DRAWING:

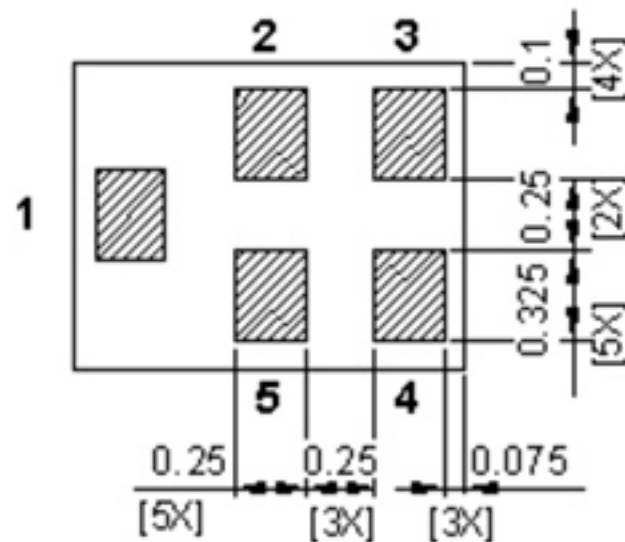
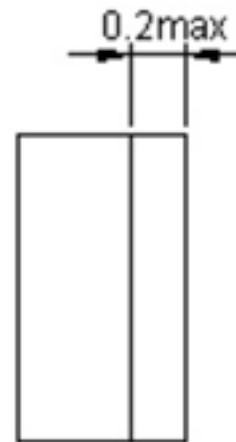
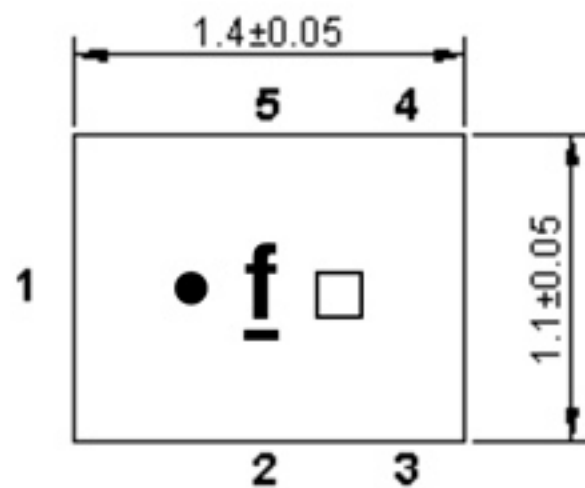

All tolerances are +/-0.05 mm unless otherwise specified

Coplanarity : 0.1 mm max.

1 to 5 : Pin No.

Unit : mm

Pin No.	Symbol	Function
1	IN	Input
2	GND	Ground
3	GND	Ground
4	OUT	Output
5	GND	Ground

□ : Year/Month Code (Follow the table)

YEAR/Month	1	2	3	4	5	6	7	8	9	10	11	12
2013	A	B	C	D	E	F	G	H	J	K	L	M
2014	N	P	Q	R	S	T	U	V	W	X	Y	Z
2015	a	b	c	d	e	f	g	h	j	k	l	m
2016	n	p	q	r	s	t	u	v	w	x	y	z
2017	<u>A</u>	<u>B</u>	<u>C</u>	<u>D</u>	<u>E</u>	<u>F</u>	<u>G</u>	<u>H</u>	<u>J</u>	<u>K</u>	<u>L</u>	<u>M</u>
2018	<u>N</u>	<u>P</u>	<u>Q</u>	<u>R</u>	<u>S</u>	<u>T</u>	<u>U</u>	<u>V</u>	<u>W</u>	<u>X</u>	<u>Y</u>	<u>Z</u>
2019	<u>a</u>	<u>b</u>	<u>c</u>	<u>d</u>	<u>e</u>	<u>f</u>	<u>g</u>	<u>h</u>	<u>i</u>	<u>k</u>	<u>l</u>	<u>m</u>
2020	<u>n</u>	<u>p</u>	<u>q</u>	<u>r</u>	<u>s</u>	<u>t</u>	<u>u</u>	<u>v</u>	<u>w</u>	<u>x</u>	<u>y</u>	<u>z</u>

D. MEASUREMENT CIRCUIT:

* By Network analyzer simulation matching with port extension

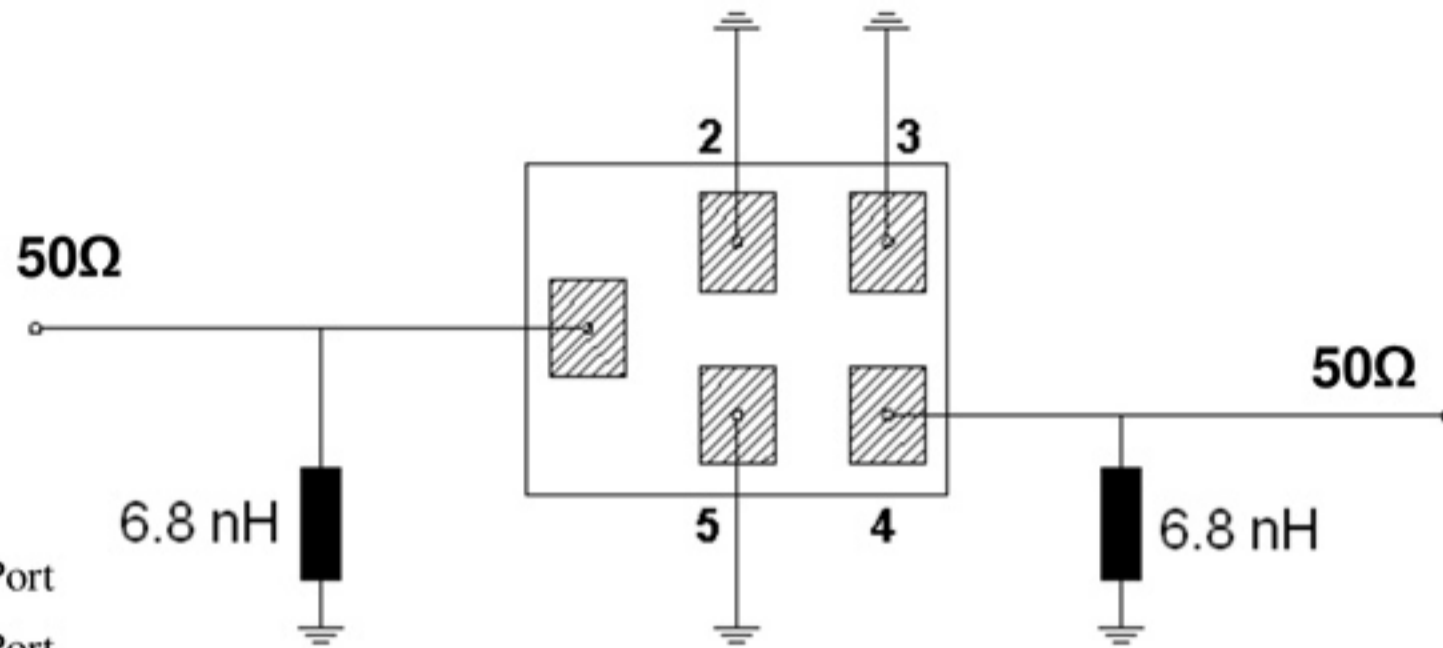

(1): Unbalance Port
(4): Unbalance Port
Others: Ground

E. PCB Footprint:

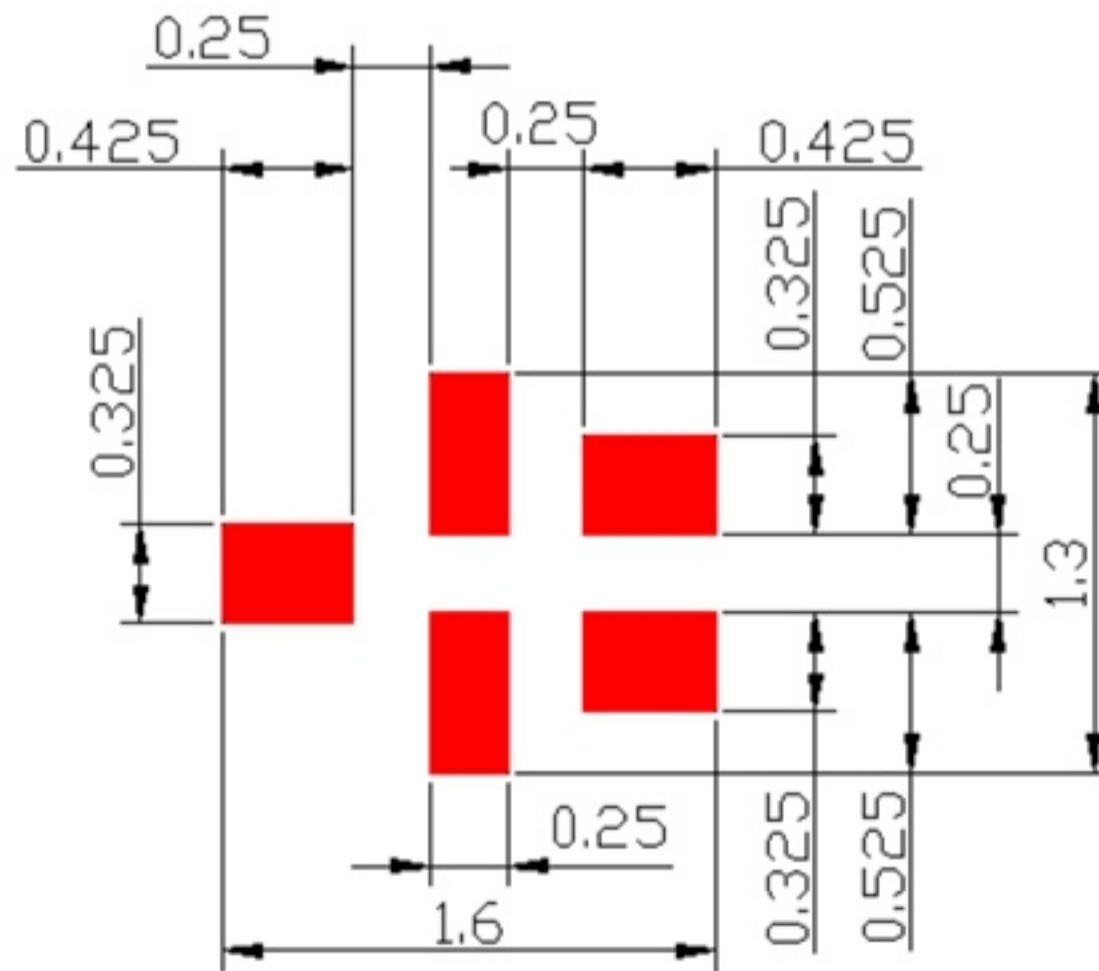

■ : Land Pattern
Unit : mm

F. Frequency Characteristics:

Span 800 MHz

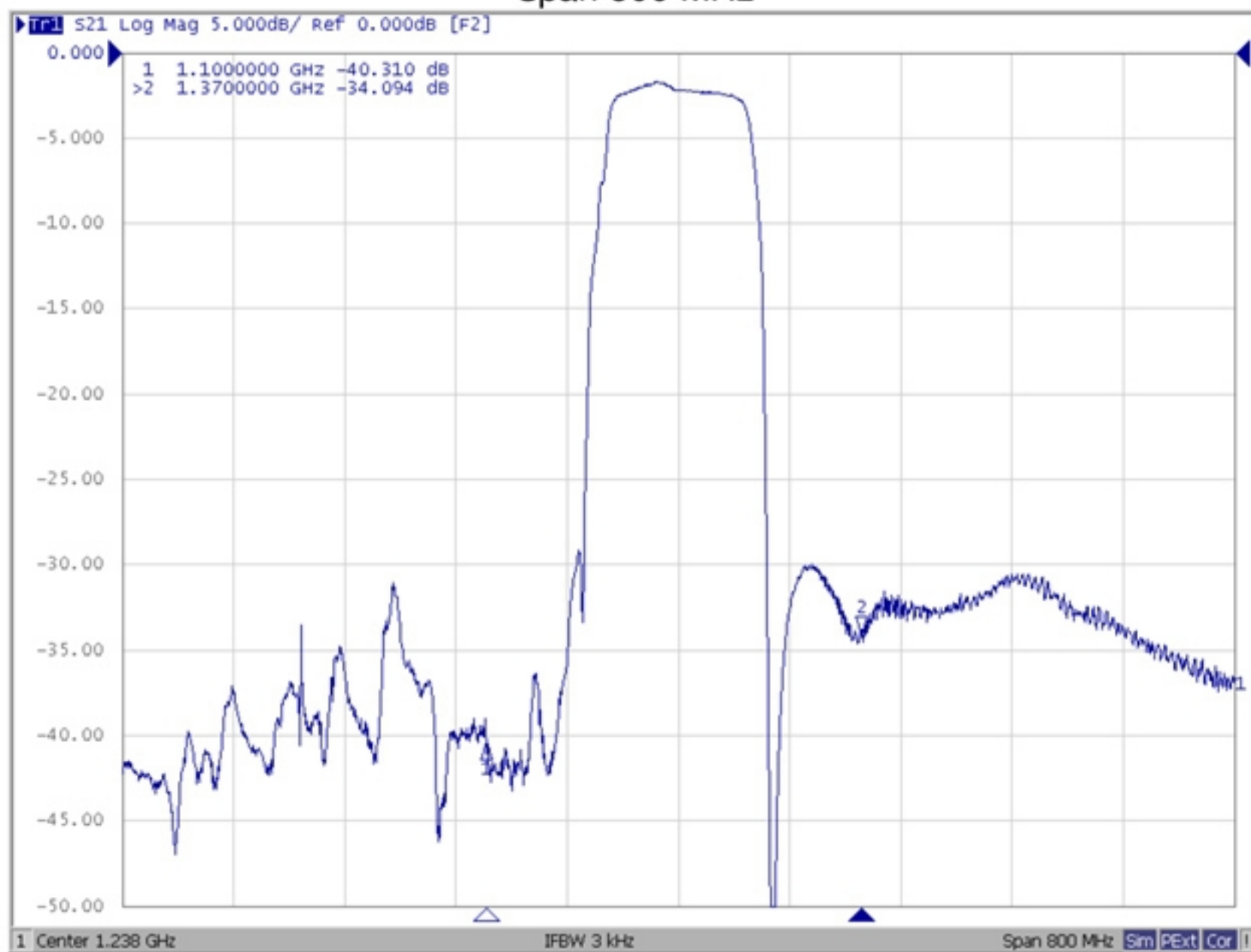

Span 3000 MHz

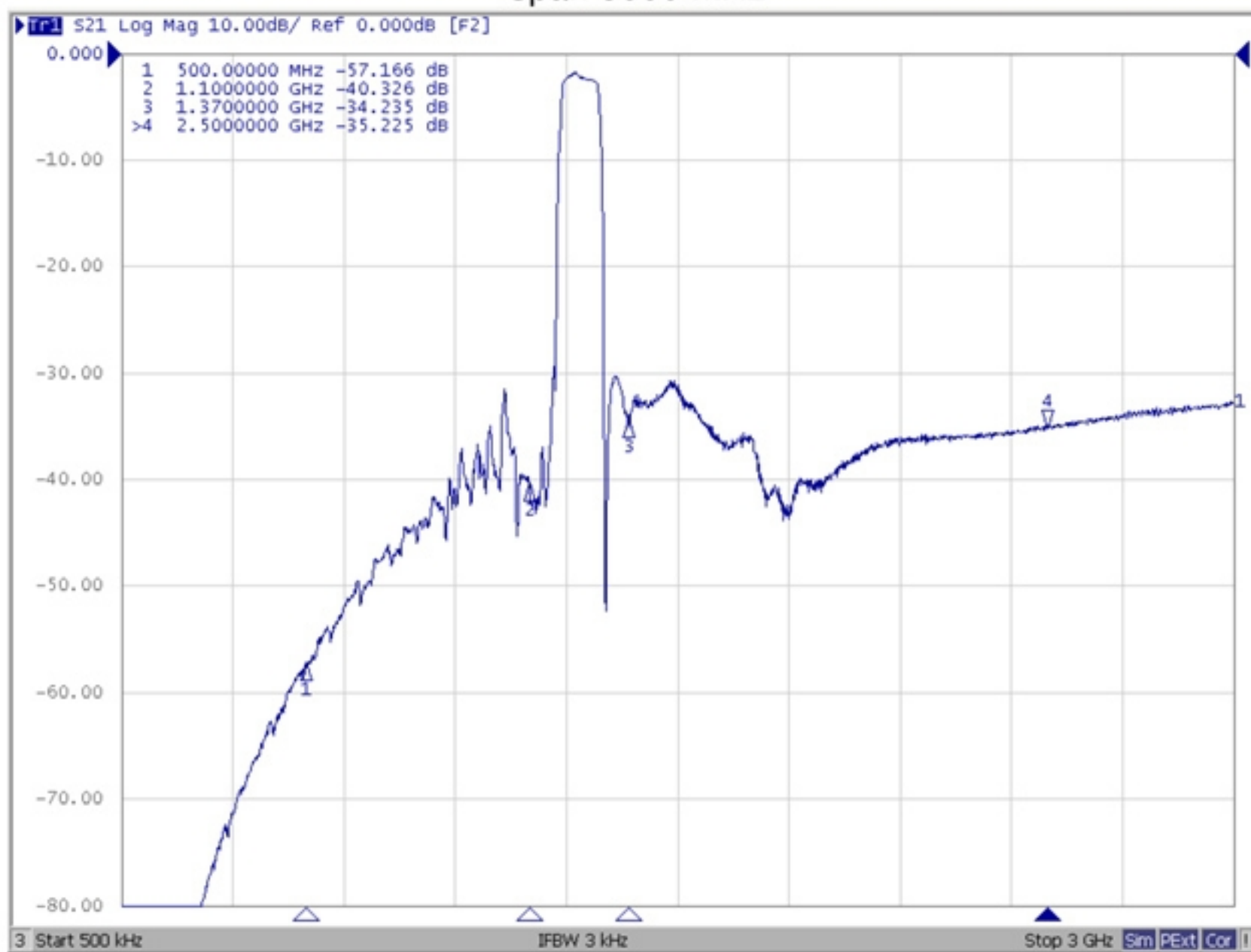

Span 200 MHz

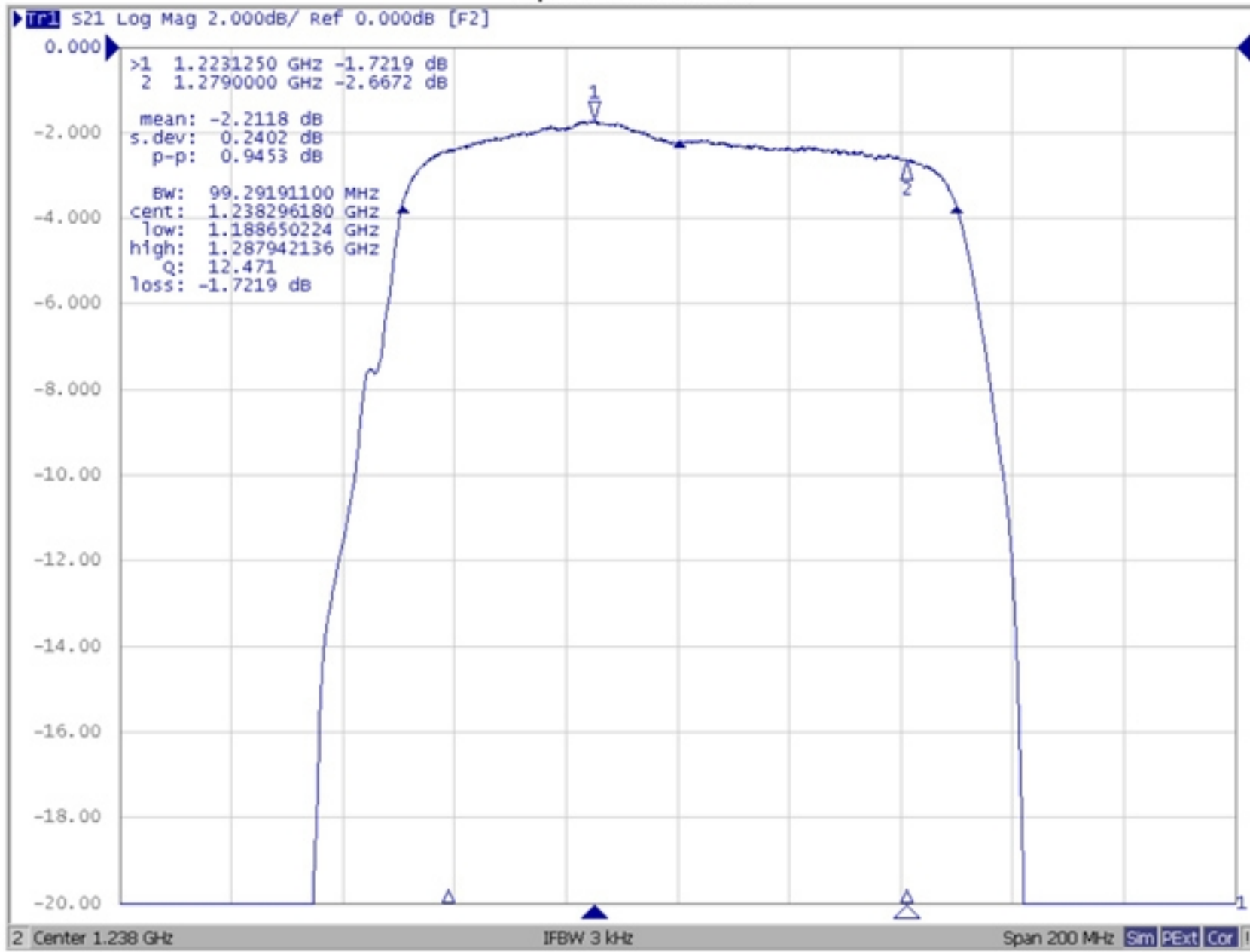

Reflection Characteristic:

Span 200 MHz

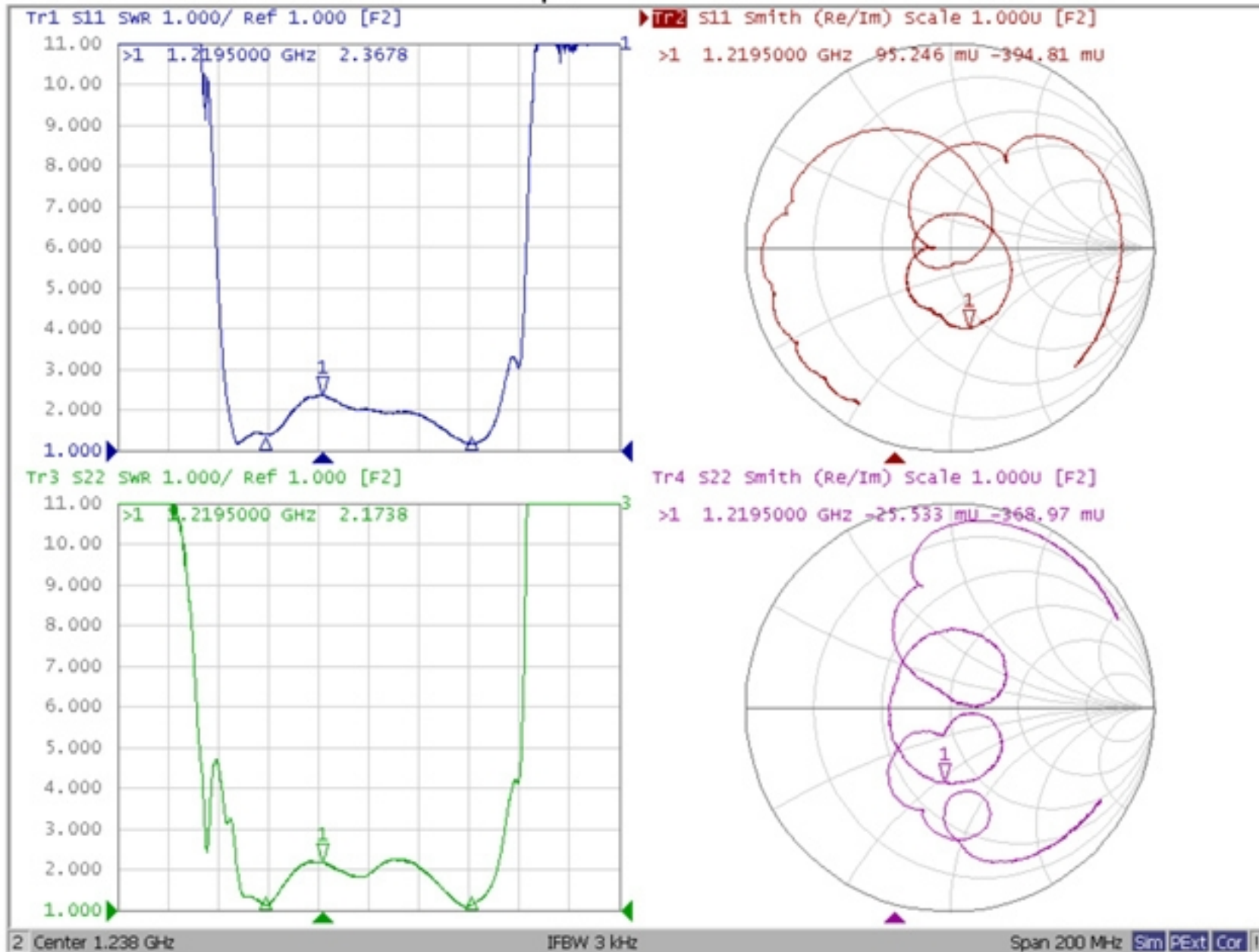

G. PACKING:

1. REEL DIMENSION

(Please refer to FR-75D10 for packing quantity)

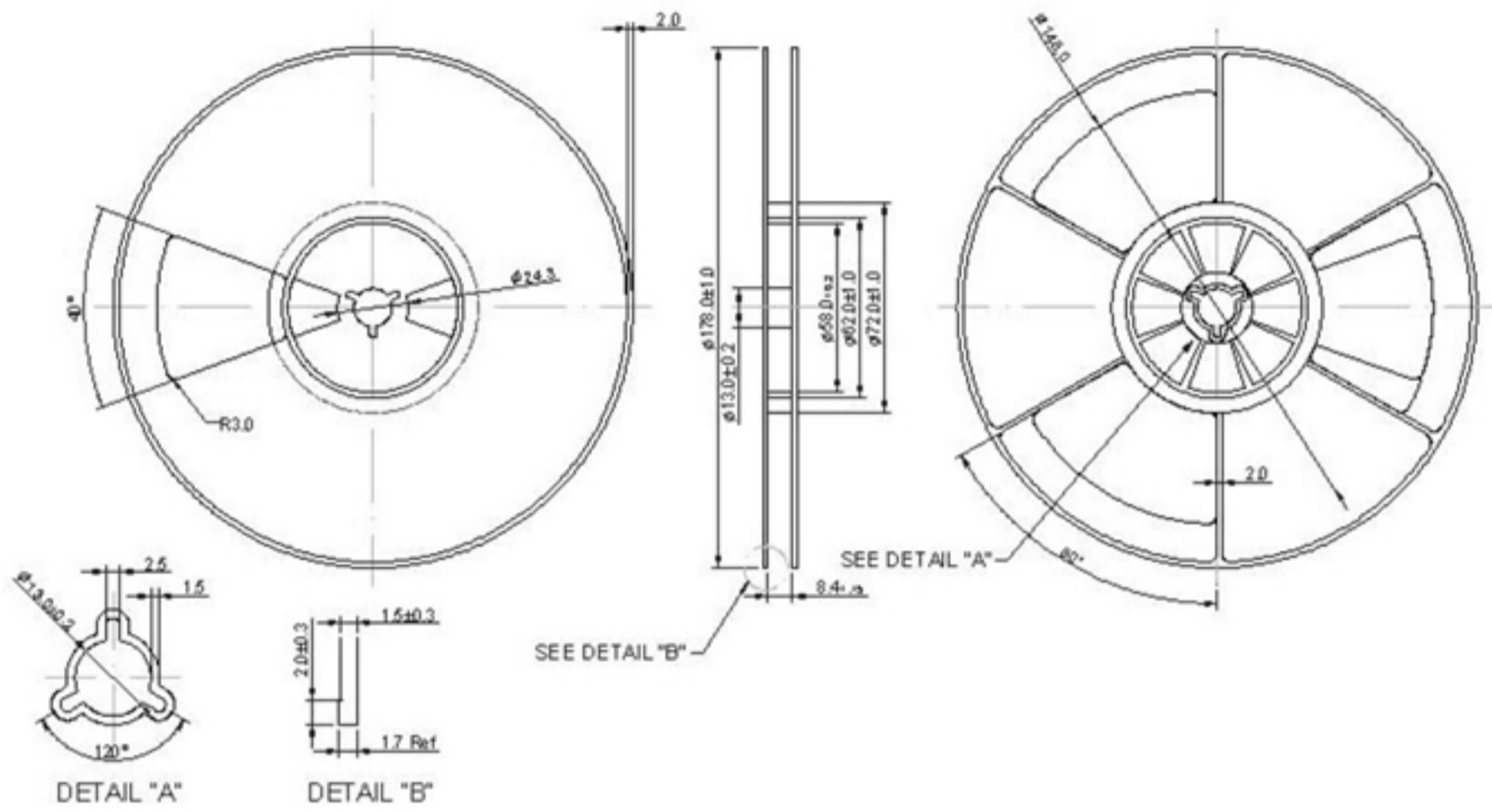

2. TAPE DIMENSION

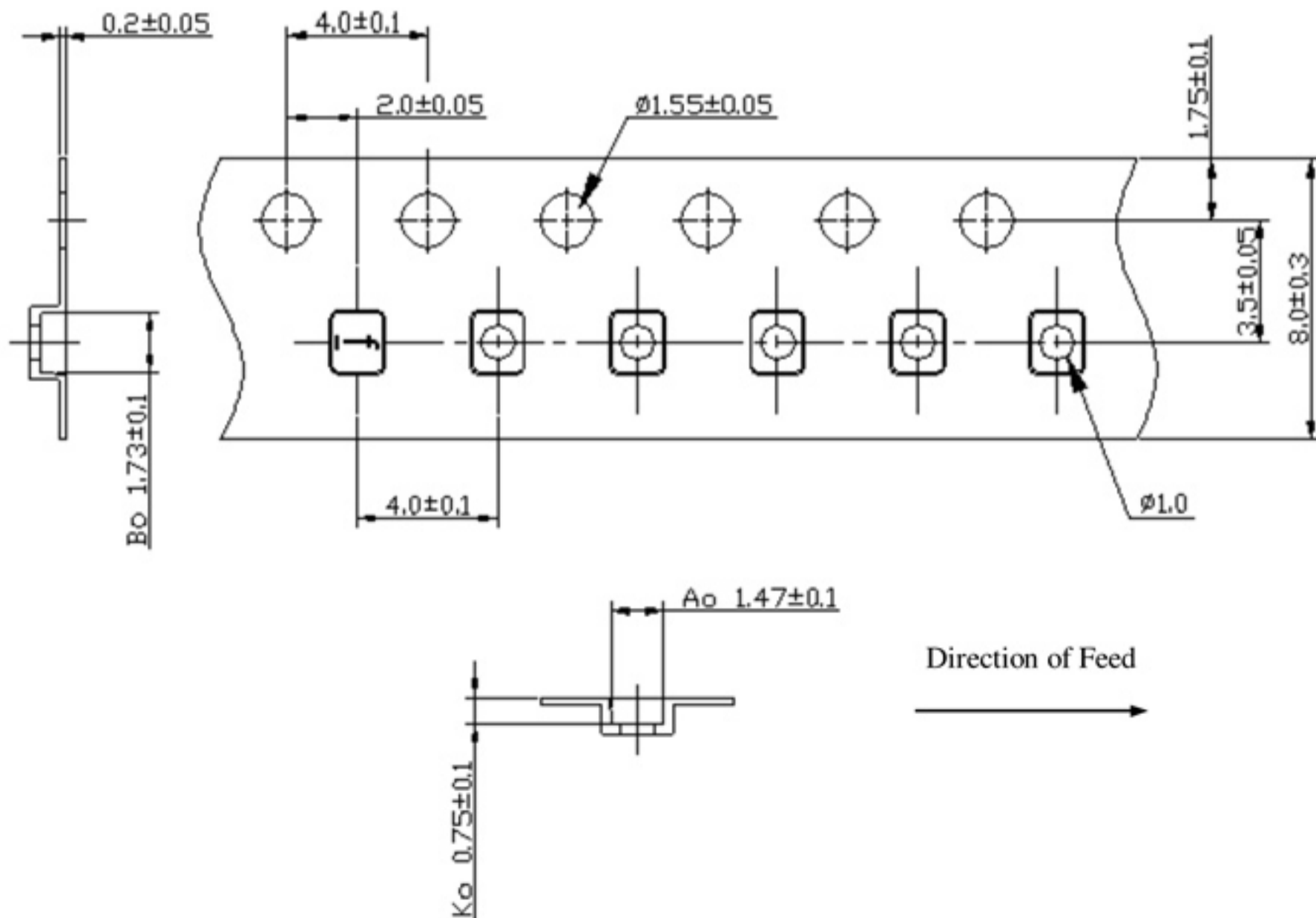

H. RECOMMENDED REFLOW PROFILE :

1. Preheating shall be fixed at $150\sim 180^{\circ}\text{C}$ for $60\sim 90$ seconds.
2. Ascending time to preheating temperature 150°C shall be 30 seconds min.
3. Heating shall be fixed at 220°C for $50\sim 80$ seconds and at $260^{\circ}\text{C} +0/-5^{\circ}\text{C}$ peak ($20\sim 40\text{sec}$).
4. Time: 2 times.

