

SAW Filter 1191.8 MHz

MODEL NO.: TA2550A

REV. NO.:2

A. MAXIMUM RATING:

1. Input Power Level: 10 dBm
2. DC Voltage : 3 V
3. Operating Temperature: -40 °C to +85 °C
4. Storage Temperature: -40 °C to +85 °C
5. Moisture Sensitivity Level: Level 2a(**MSL 2a**)

RoHS Compliant
Lead-free soldering

Electrostatic Sensitive Device (**ESD**)

B. ELECTRICAL CHARACTERISTICS:

Item	Unit	Min.	Typ.	Max.	
Center frequency	Fc	MHz	-	1191.8	-
Insertion loss (1164.3~1219.3 MHz)	IL	dB	-	2.0	4.0
Amplitude ripple (1169.8~1213.8 MHz)		dB	-	0.5	1.2
Group delay ripple (1164.3~1219.3 MHz)		ns	-	17	50
Attenuation (Reference level from 0 dB)					
10 ~ 1040 MHz		dB	30	34	-
1040 ~ 1126 MHz		dB	20	30	-
1256 ~ 1345 MHz		dB	20	31	-
1345 ~ 1650 MHz		dB	22	27	-
1650 ~ 3000 MHz		dB	22	28	-
Temperature coefficient of frequency		ppm/k	-	-36	-

C. MEASUREMENT CIRCUIT:

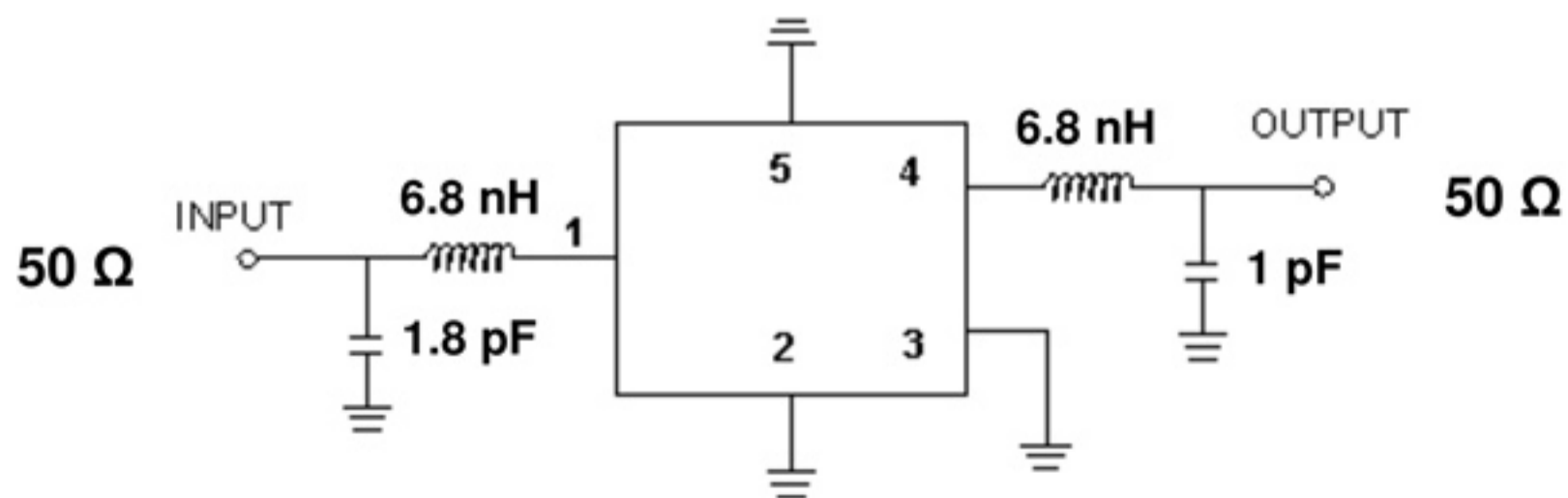

(1): Unbalance Port

(4): Unbalance Port

Others: Ground

D. OUTLINE DRAWING:

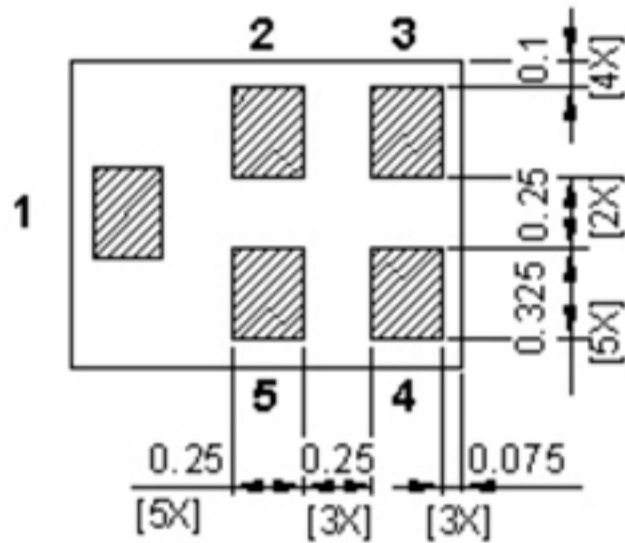
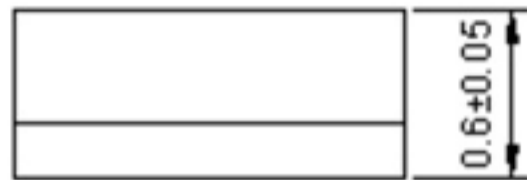
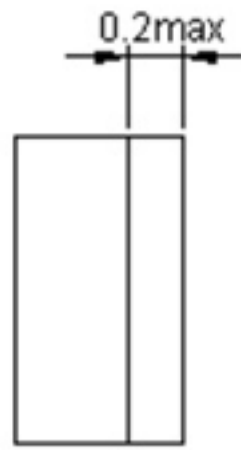
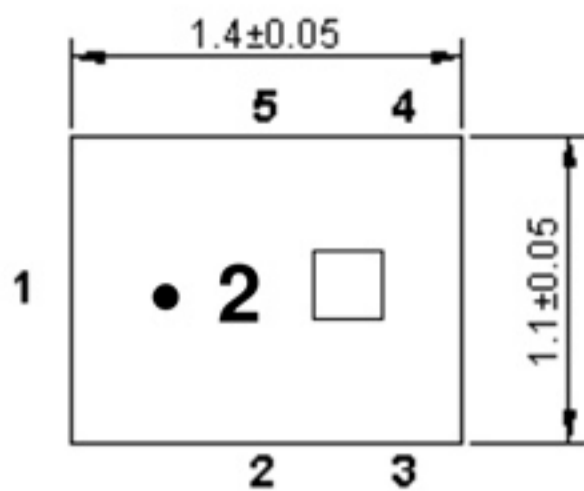

All tolerances are +/-0.05 mm unless otherwise specified
 Coplanarity : 0.1 mm max.
 1 to 5 : Pin No.
 Unit : mm

Pin No.	Symbol	Function
1	IN	Input
2	GND	Ground
3	GND	Ground
4	OUT	Output
5	GND	Ground

□ : Year/Month Code (Follow the table)

YEAR/Month	1	2	3	4	5	6	7	8	9	10	11	12
2013	A	B	C	D	E	F	G	H	J	K	L	M
2014	N	P	Q	R	S	T	U	V	W	X	Y	Z
2015	a	b	c	d	e	f	g	h	j	k	l	m
2016	n	p	q	r	s	t	u	v	w	x	y	z
2017	<u>A</u>	<u>B</u>	<u>C</u>	<u>D</u>	<u>E</u>	<u>F</u>	<u>G</u>	<u>H</u>	<u>J</u>	<u>K</u>	<u>L</u>	<u>M</u>
2018	<u>N</u>	<u>P</u>	<u>Q</u>	<u>R</u>	<u>S</u>	<u>T</u>	<u>U</u>	<u>V</u>	<u>W</u>	<u>X</u>	<u>Y</u>	<u>Z</u>
2019	<u>a</u>	<u>b</u>	<u>c</u>	<u>d</u>	<u>e</u>	<u>f</u>	<u>g</u>	<u>h</u>	<u>i</u>	<u>k</u>	<u>l</u>	<u>m</u>
2020	<u>n</u>	<u>p</u>	<u>q</u>	<u>r</u>	<u>s</u>	<u>t</u>	<u>u</u>	<u>v</u>	<u>w</u>	<u>x</u>	<u>y</u>	<u>z</u>

E. PCB Footprint:

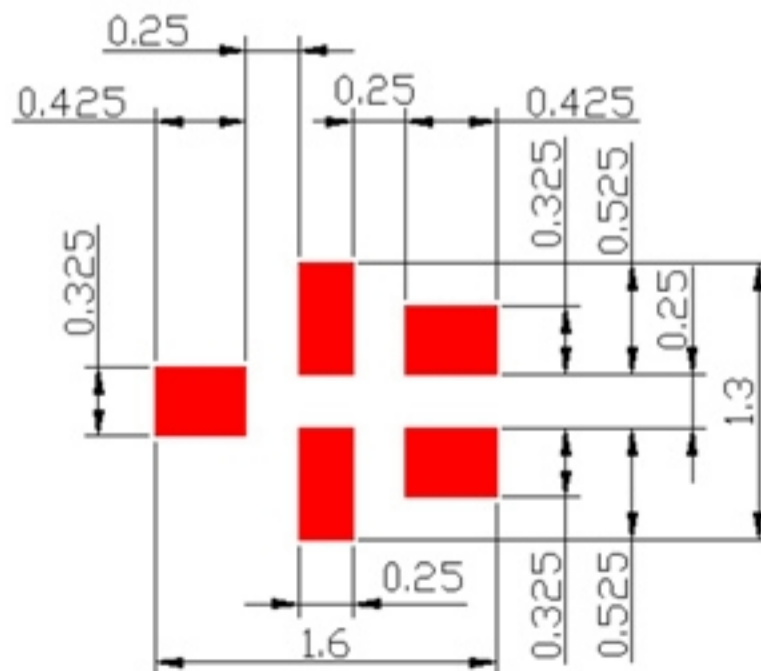

■ : Land Pattern
 Unit : mm

F. Frequency Characteristics:

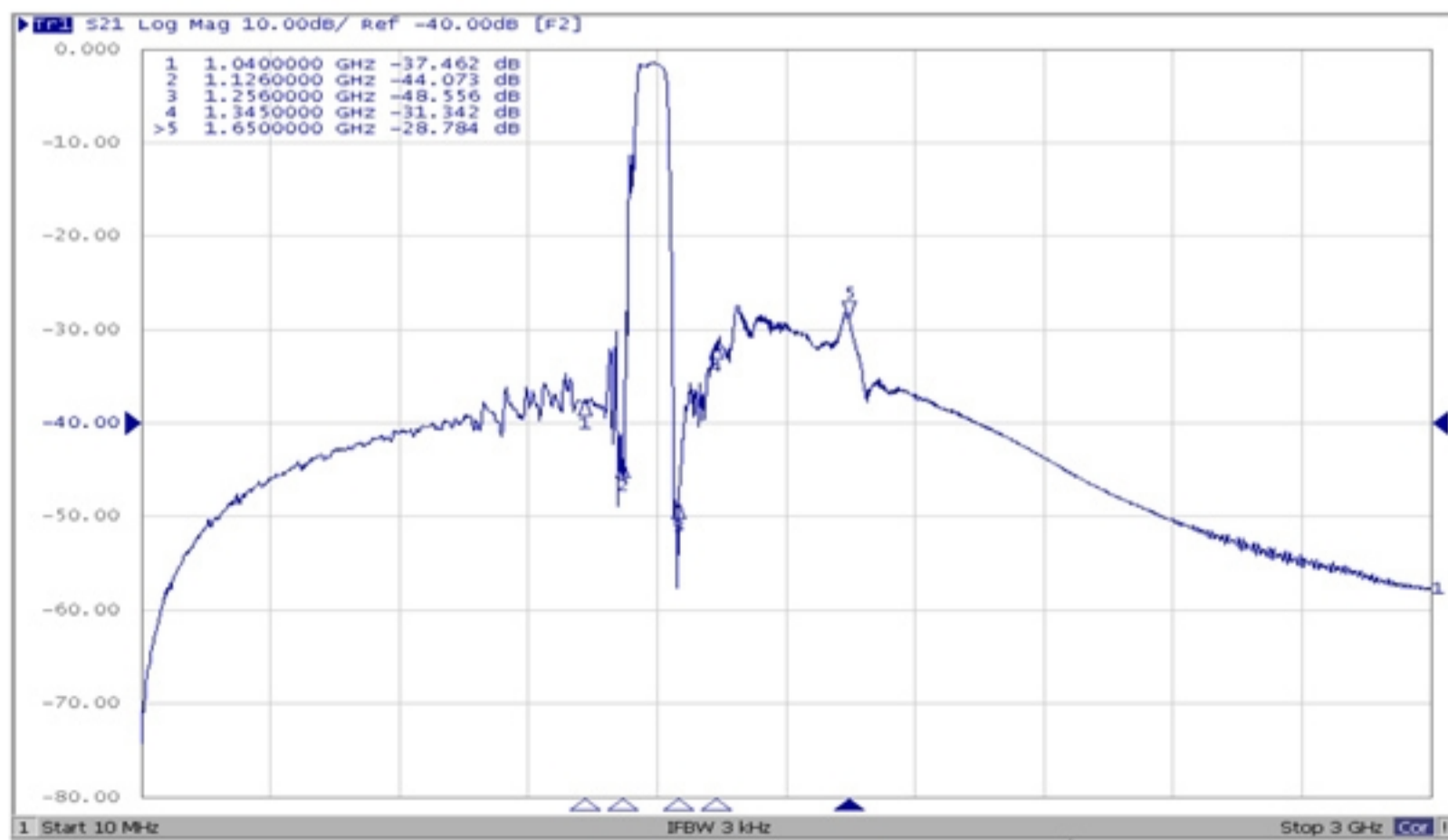
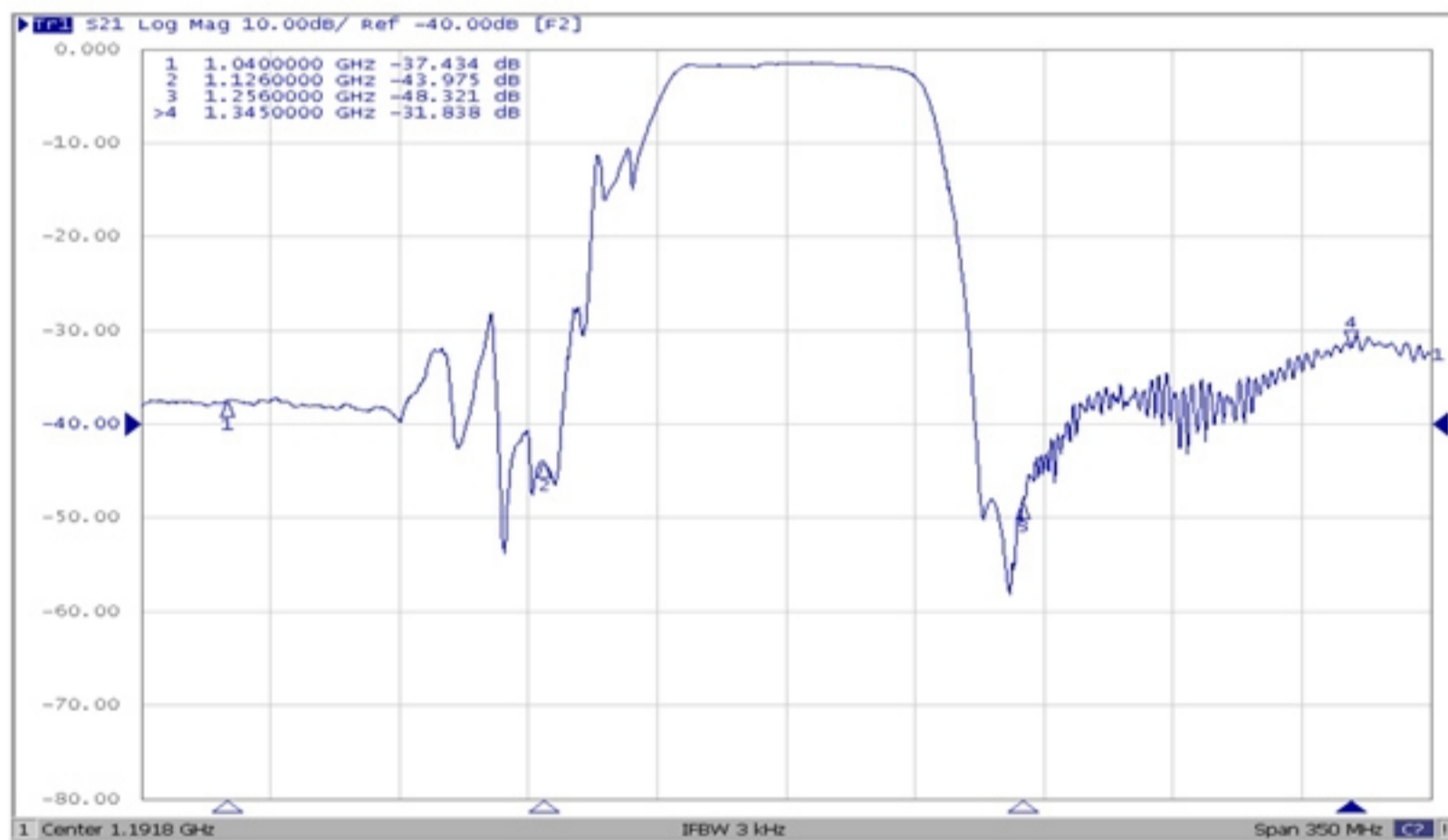
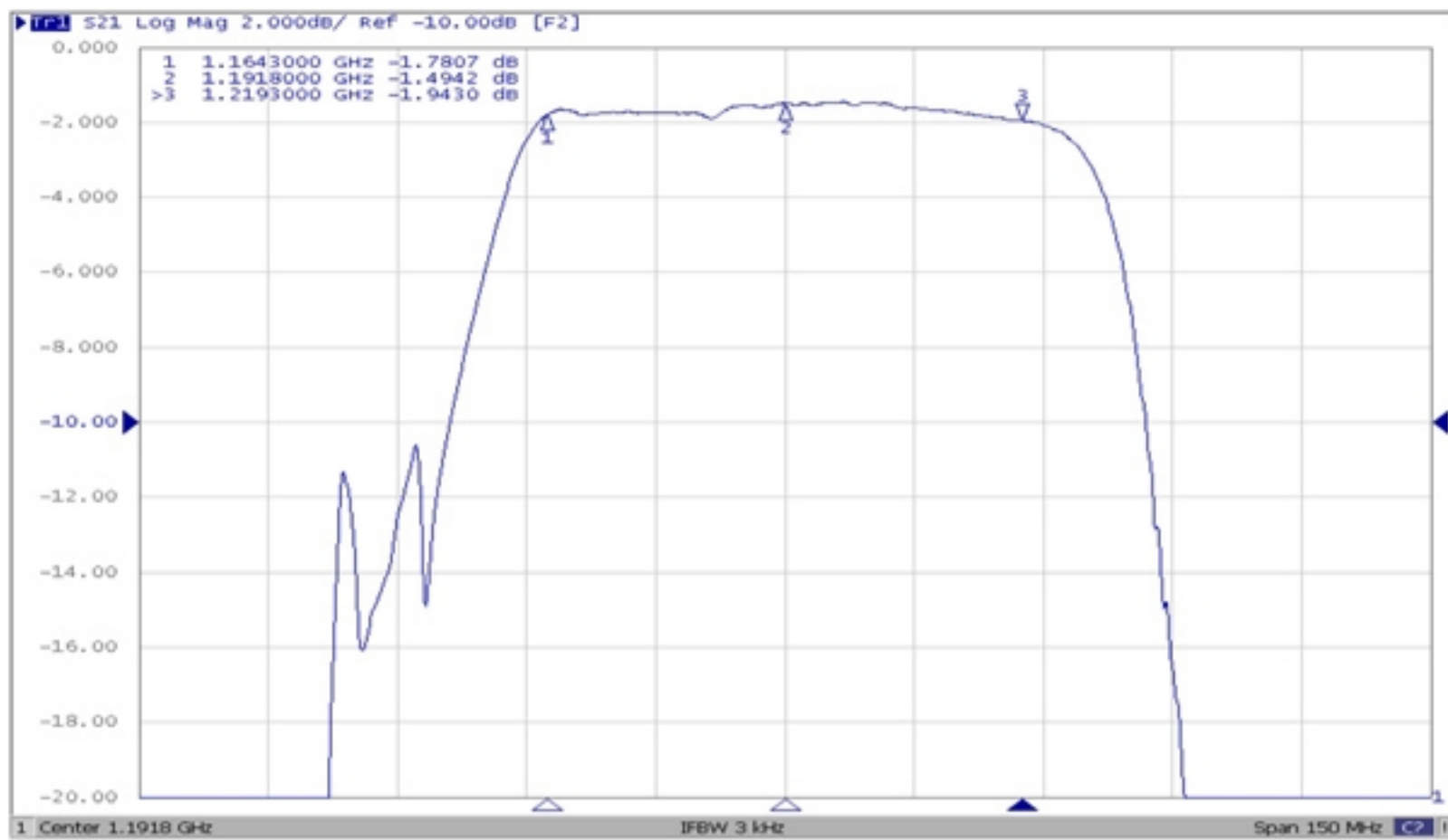

G. PACKING: (Ref. WI-75M03)

1. REEL DIMENSION

(Please refer to FR-75D10 for packing quantity)

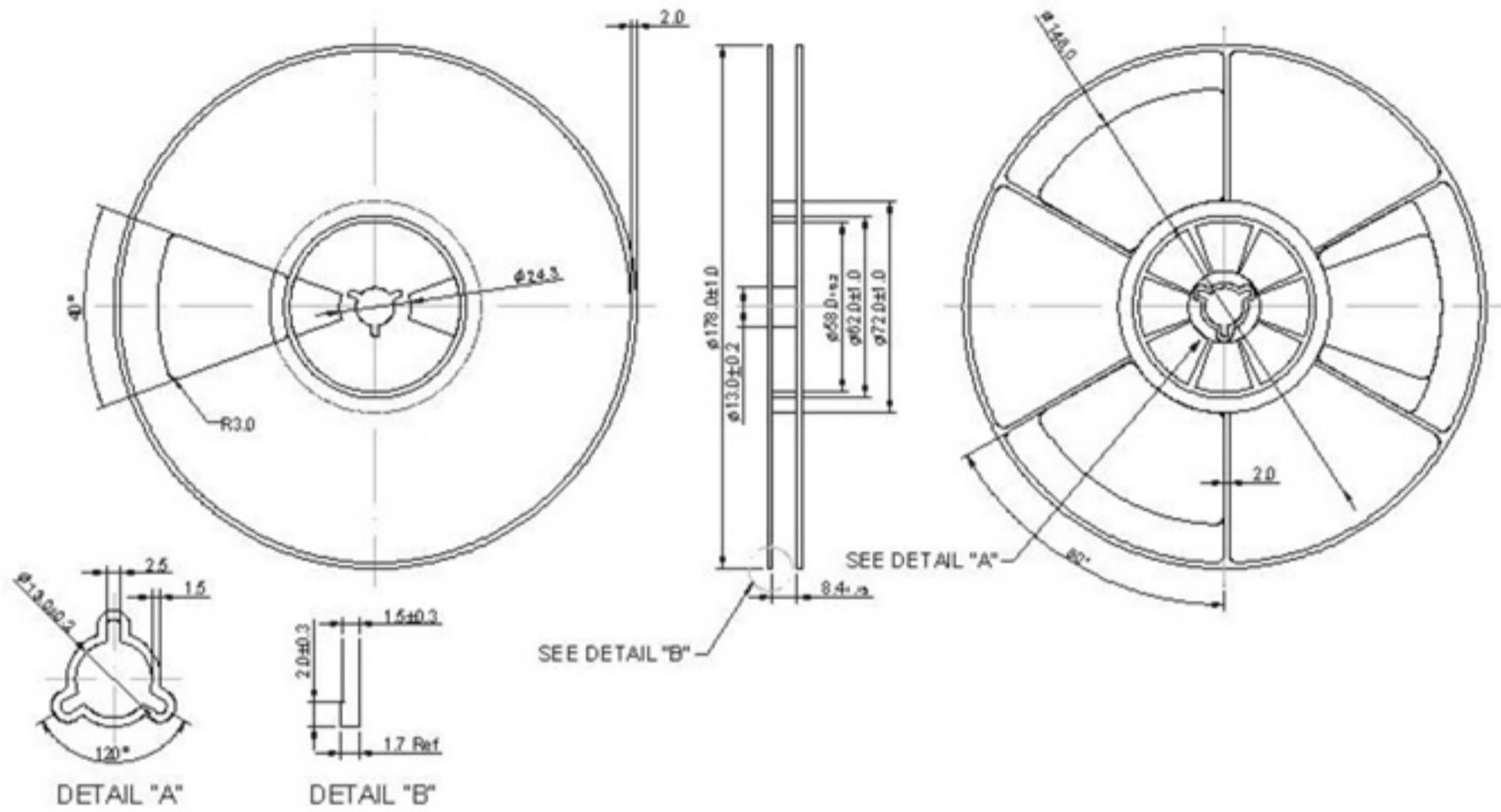

2. 2. TAPE DIMENSION

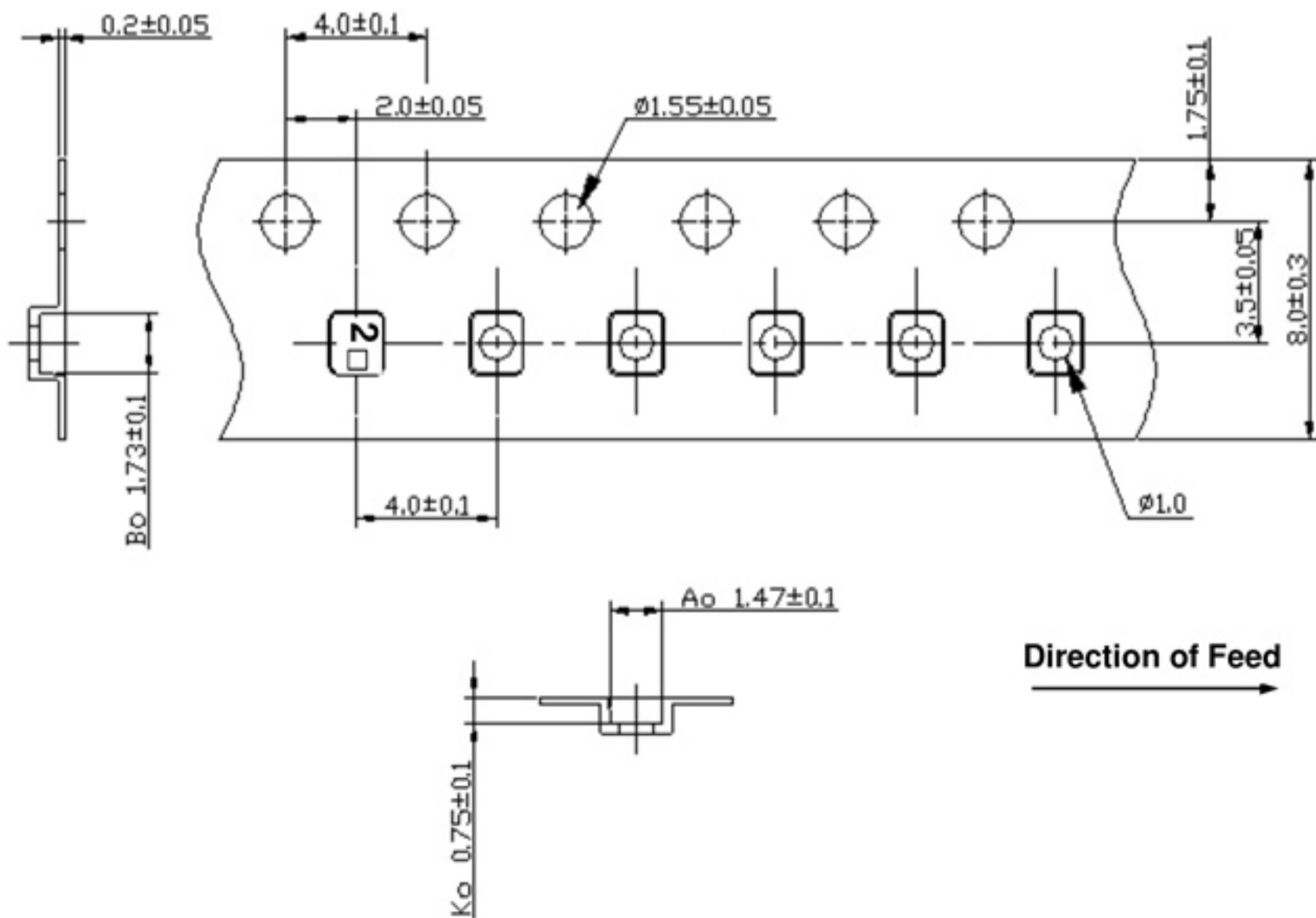

H. Recommended Reflow Profile:

1. Preheating shall be fixed at $150\sim 180^{\circ}\text{C}$ for 60~90 seconds.
2. Ascending time to preheating temperature 150°C shall be 30 seconds min.
3. Heating shall be fixed at 220°C for 50~80 seconds and at $260^{\circ}\text{C} +0/-5^{\circ}\text{C}$ peak (20~40sec).
4. Time: 2 times.

