



TAI-SAW TECHNOLOGY CO., LTD.

No. 3, Industrial 2nd Rd., Ping-Chen Industrial District,
Taoyuan, 324, Taiwan, R.O.C.

TEL: 886-3-4690038 FAX: 886-3-4697532

E-mail: tstsales@mail.taisaw.com Web: www.taisaw.com

Product Specifications Approval Sheet

Product Description: SAW Rx Filter 2140MHz LTE Band 1 SMD 1109

TST Part No.: TA1845DA

Customer Part No.: _____

Customer signature required
Company: _____
Division: _____
Approved by : _____
Date: _____

Checked by: _____ Michael Yang *Michael*

Approved by: _____ Andy Yu *Andy Yu*

Date: _____ 2019/10/09

- 1. Customer signed back is required before TST can proceed with sample build and receive orders.
- 2. Orders received without customer signed back will be regarded as agreement on the specifications.
- 3. Any specifications changes must be approved upon by both parties and a new revision of specifications shall be released to reflect the change



TAI-SAW TECHNOLOGY CO., LTD.

No. 3, Industrial 2nd Rd., Ping-Chen Industrial District,
Taoyuan, 324, Taiwan, R.O.C.

TEL: 886-3-4690038 FAX: 886-3-4697532

E-mail: tstsales@mail.taisaw.com Web: www.taisaw.com

SAW Rx Filter 2140MHz LTE Band 1 SMD 1109

MODEL NO.: TA1845DA

REV. NO.:1.0

A. MAXIMUM RATING:

1. Operating temperature range: -30 °C to +85 °C
2. Storage temperature range: -40 °C to +85 °C
3. Maximum Input Power: +10 dBm
4. Maximum DC Voltage: +/-0 V
5. Moisture Sensitivity Level: Level 3
6. ESD 50V(MM) 100V(HBM)

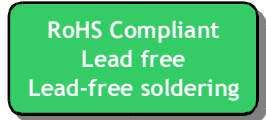

Electrostatic Sensitive Device (ESD)

B. ELECTRICAL CHARACTERISTICS:

Terminating source impedance: $Z_s = 50 \Omega$ (Single-ended)

Terminating load impedance: $Z_L = 50 \Omega$ (Single-ended)

Parameters Description			Unit	Minimum	Typical	Maximum
Center Frequency			MHz	-	2140	-
Insertion Loss	2110~2170 MHz		dB	-	1.9	3.0
	2110~2155 MHz		dB	-	1.9	2.5
Amplitude Ripple	2110~2170 MHz		dBp-p	-	0.6	2.0
	2110~2155 MHz		dBp-p	-	0.6	1.5
VSWR	Input	2110~2170 MHz	-	-	1.8	2.2
	Output	2110~2155 MHz	-	-	1.8	2.2
Attenuation:						
50-1710 MHz			dB	35	43	-
1710-1755 MHz			dB	40	47	-
1920-1980 MHz			dB	35	40	-
4220-4340 MHz			dB	25	33	-

C. FREQUENCY CHARACTERISTICS:

S21 response: (span 500MHz)

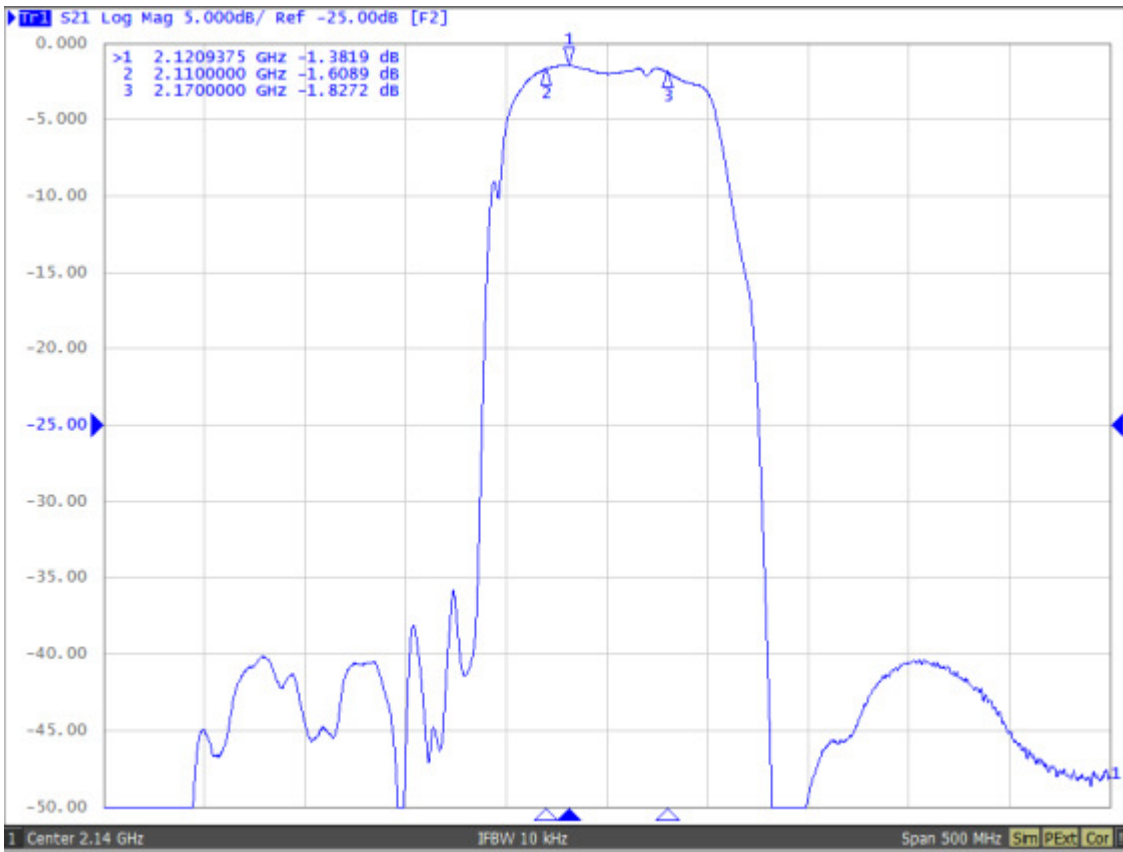

S21 response: (span 200MHz)



S21 response: (span 4.5GHz)

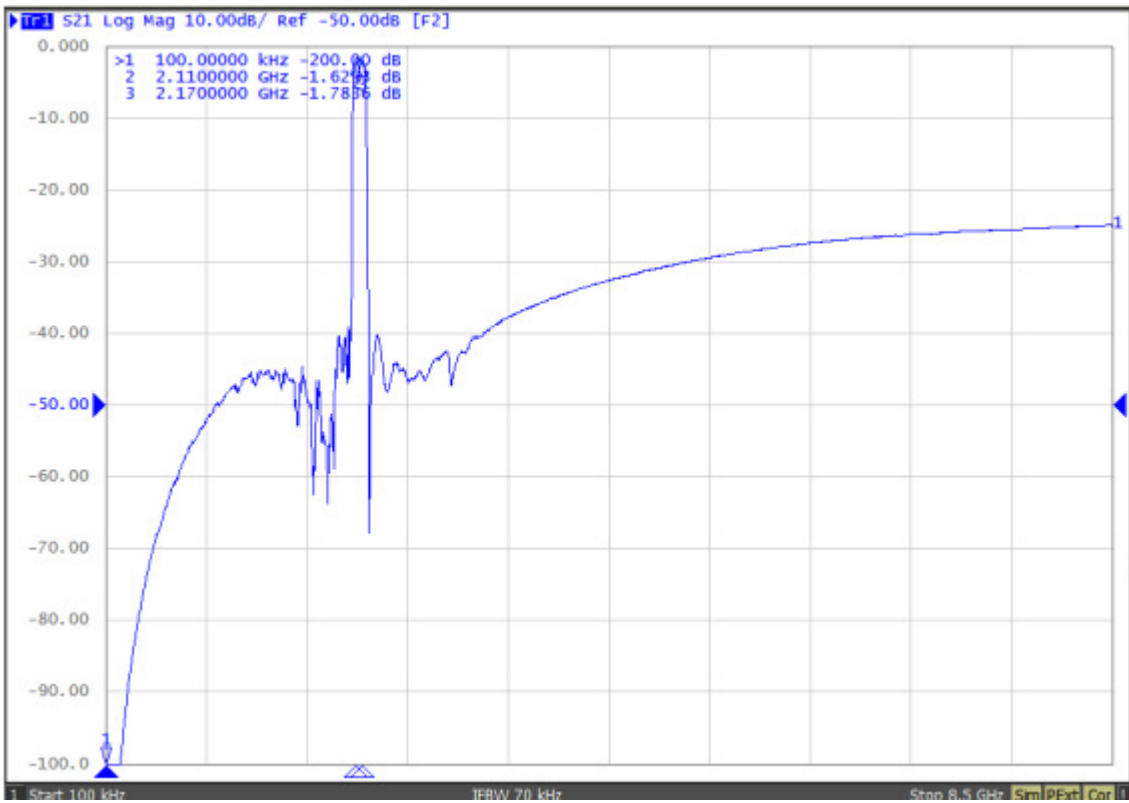

S11/S22 response :

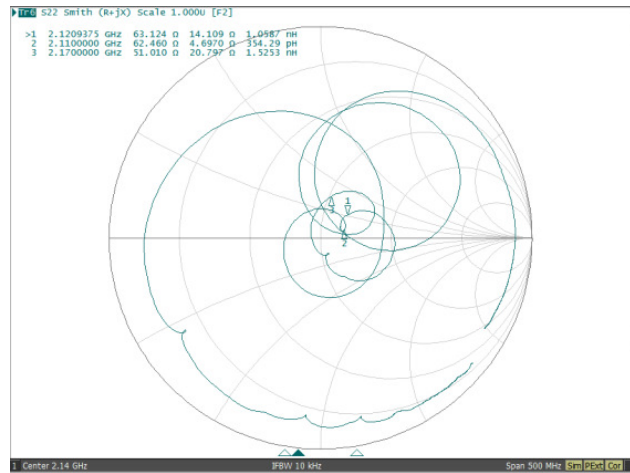
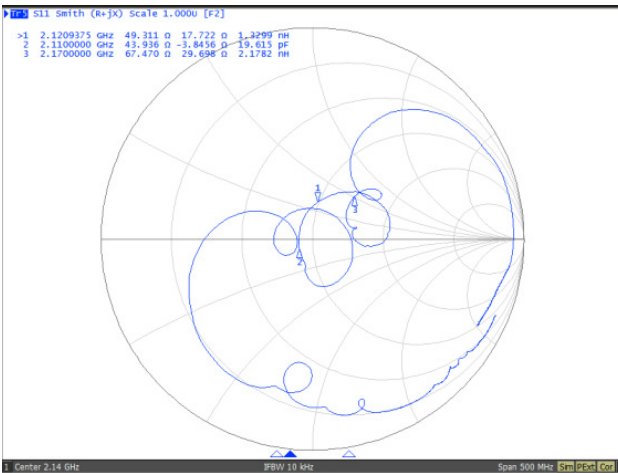

D.OUTLINE DRAWING:

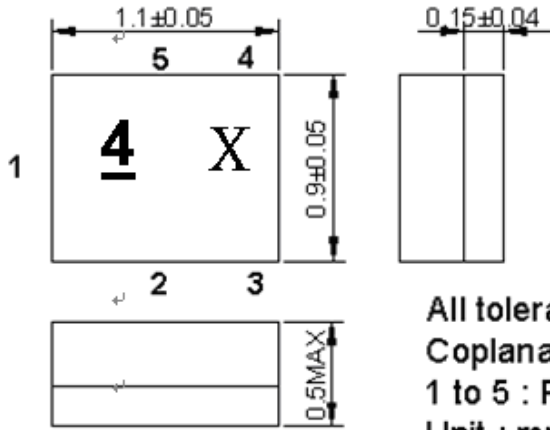

All tolerances are +/-0.05 mm unless otherwise specified
 Coplanarity : 0.1 mm max.
 1 to 5 : Pin No.
 Unit : mm

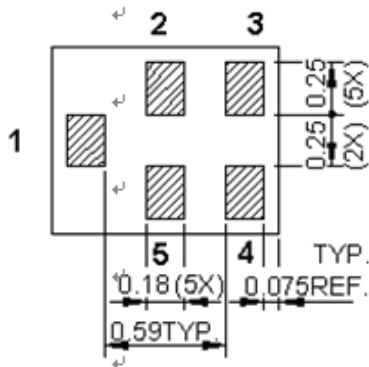

Pin No.	Symbol	Function
1	IN	Input
2	GND	Ground
3	GND	Ground
4	OUT	Output
5	GND	Ground

Marking Descriptions:

4 : Series Number

X : Year/Month Code (Follow the table)

YEAR/Month	1	2	3	4	5	6	7	8	9	10	11	12
2013	A	B	C	D	E	F	G	H	J	K	L	M
2014	N	P	Q	R	S	T	U	V	W	X	Y	Z
2015	a	b	c	d	e	f	g	h	j	k	l	m
2016	n	p	q	r	s	t	u	v	w	x	y	z
2017	<u>A</u>	<u>B</u>	<u>C</u>	<u>D</u>	<u>E</u>	<u>F</u>	<u>G</u>	<u>H</u>	<u>J</u>	<u>K</u>	<u>L</u>	<u>M</u>
2018	<u>N</u>	<u>P</u>	<u>Q</u>	<u>R</u>	<u>S</u>	<u>T</u>	<u>U</u>	<u>V</u>	<u>W</u>	<u>X</u>	<u>Y</u>	<u>Z</u>
2019	<u>a</u>	<u>b</u>	<u>c</u>	<u>d</u>	<u>e</u>	<u>f</u>	<u>g</u>	<u>h</u>	<u>j</u>	<u>k</u>	<u>l</u>	<u>m</u>
2020	<u>n</u>	<u>p</u>	<u>q</u>	<u>r</u>	<u>s</u>	<u>t</u>	<u>u</u>	<u>v</u>	<u>w</u>	<u>x</u>	<u>y</u>	<u>z</u>

E. MEASUREMENT CIRCUIT:

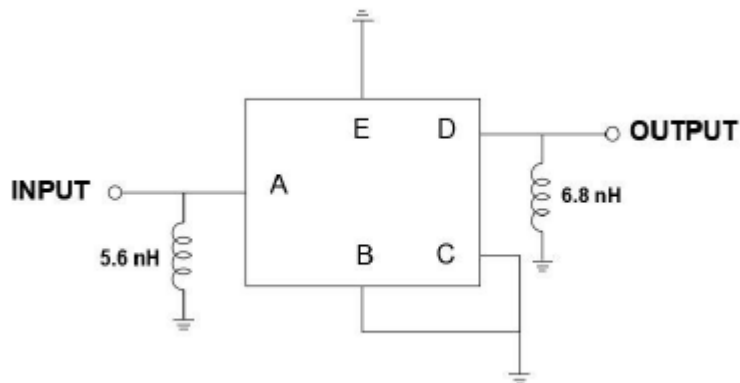

F. PCB Footprint :

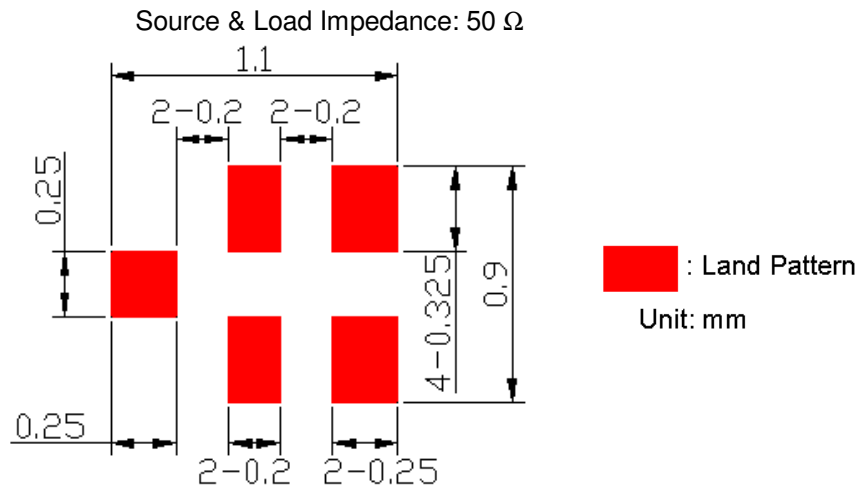

G. PACKING:

1. REEL DIMENSION

(Please refer to FR-75D10 for packing quantity)

