

Dielectric filter 1581 MHz

MODEL NO.: TR0021A

REV. NO.:1

A. MAXIMUM RATING:

1. Input Power Level: 1 W
2. DC Voltage : 0 V
3. Operating Temperature: -40 °C to +85 °C
4. Storage Temperature:-40 °C to +85 °C
5. Moisture Sensitivity Level: Level 2a (MSL 2a)
- 6.

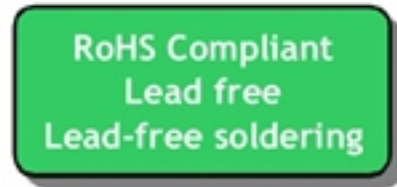

Electrostatic Sensitive Device (ESD)

B. ELECTRICAL CHARACTERISTICS:

Terminating source impedance (single ended) : $Z_s = 50 \Omega$
Terminating load impedance (single ended) : $Z_L = 50 \Omega$

NO.	Item	Unit	Spec		
			min.	typ.	max.
1	Central Frequency	MHz	1581		
2	Band Width	MHz	80		
3	Pass Band Insertion Loss	dB		0.9dB	1.0dB
4	Pass Band Ripple	dB		0.5dB	0.8dB
5	Pass Band Return Loss	dB	12dB		
6	Stop-Band Attenuation at 1400 MHz	dB	30dB	40dB	

Item NO.6 specifies the absolute value of attenuation.

C. OUTLINE DRAWING:

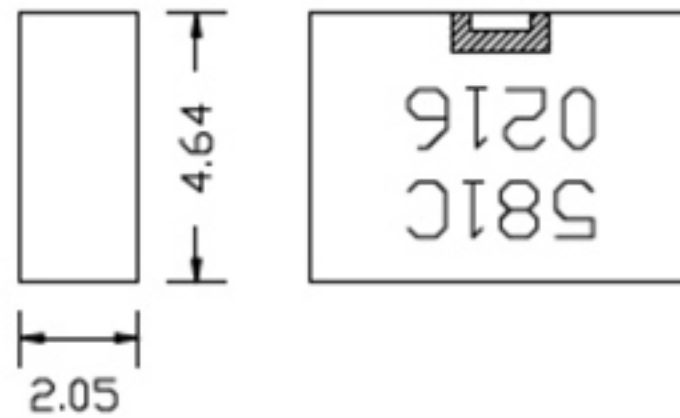
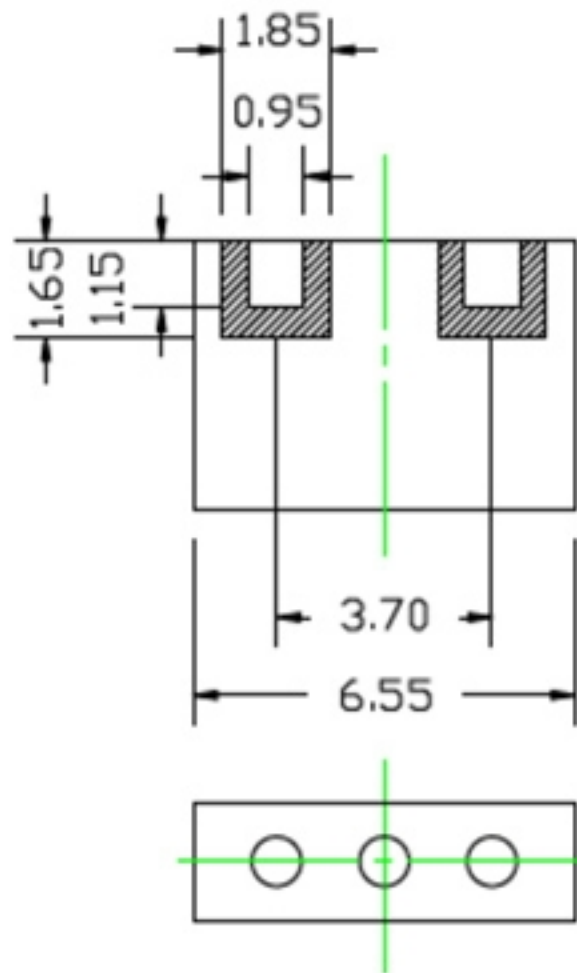

581C : product name(J1581C)
02 : month
16 : year (2016)

Unit:mm
Tolerance:±0.3

D. PCB Footprint

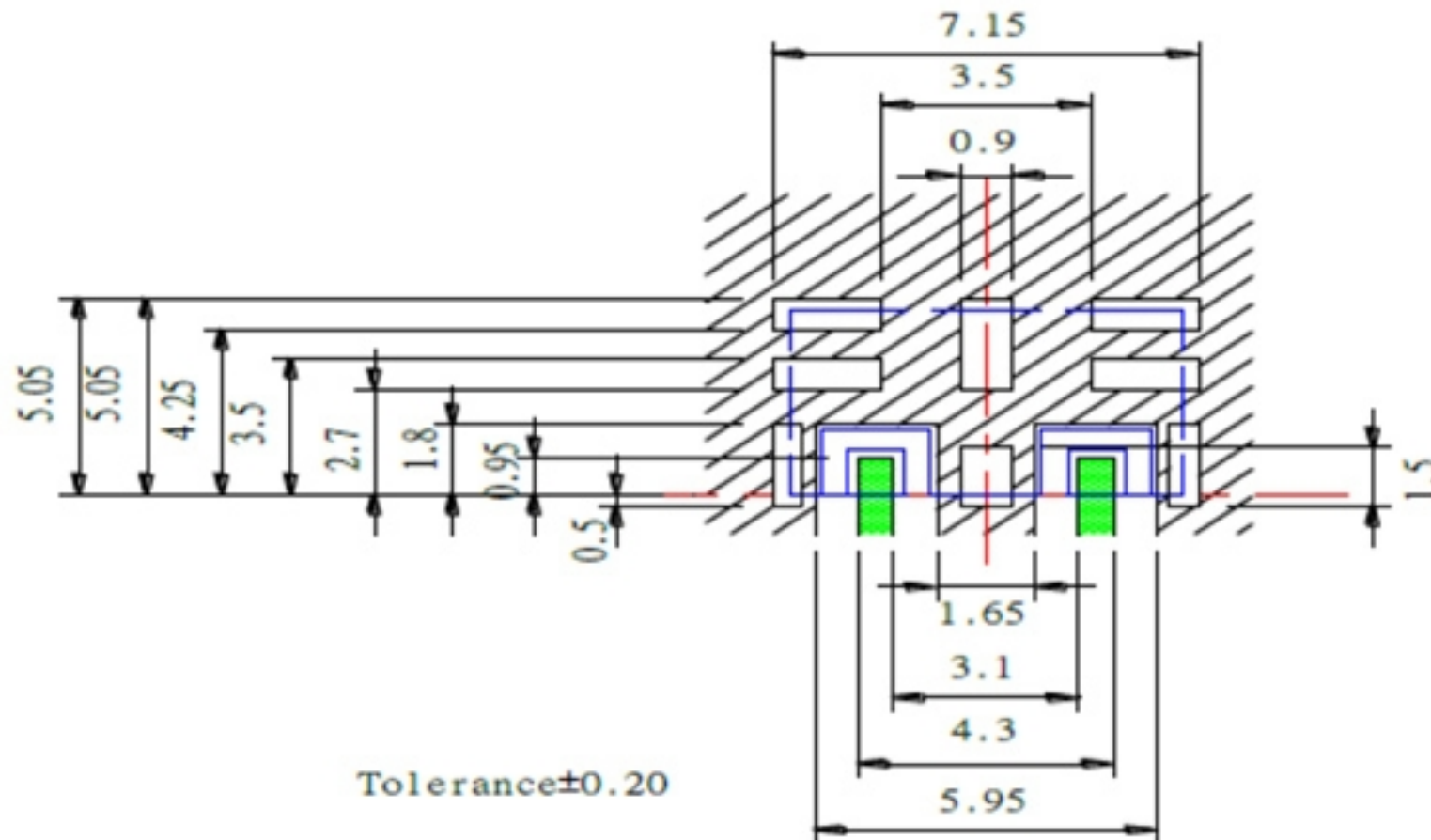

Conductive Material:
Ground, connected to
lower ground diameter of
0.3mm and max.distance
of 1.0mm.



I/O Pads and LAND,
I/O must be connected to lines with
 50Ω impedance.
in the application a
termination of 50Ω
must be realized.



Solder Resist Without
Pattern

E. DELIVERY MODE:

1. REEL

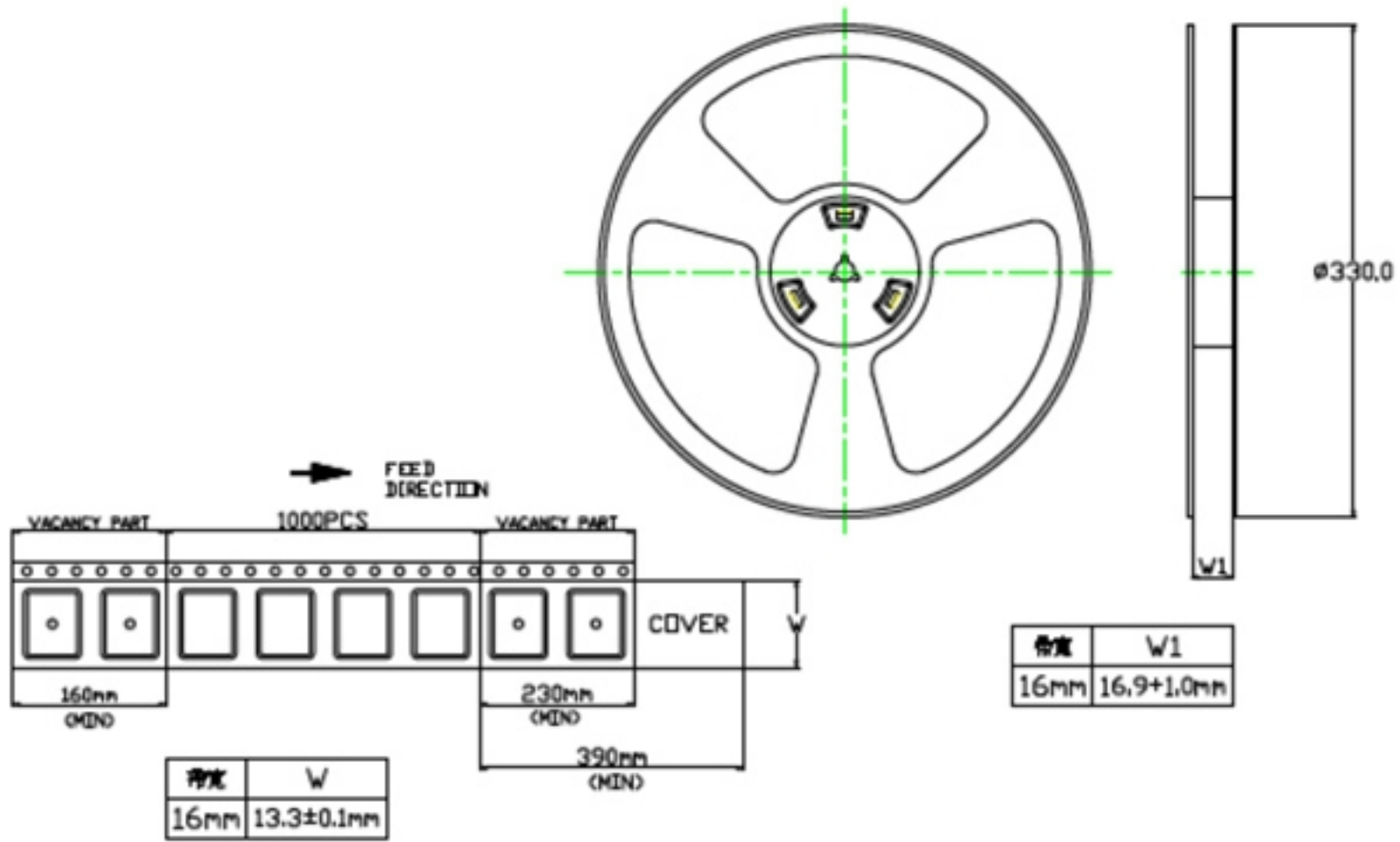

2. TAPE

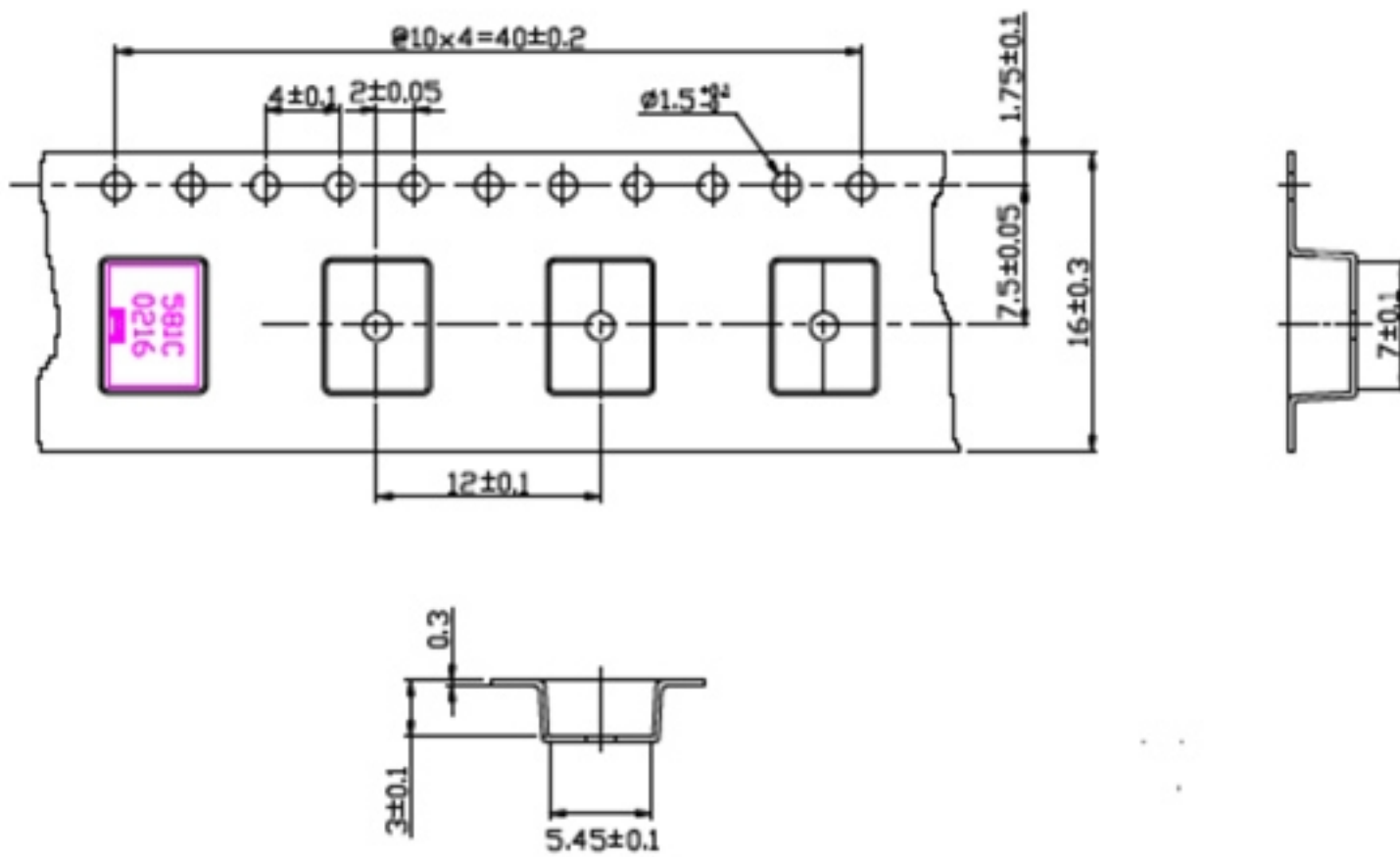

3. PACKAGE STYLE

- 1. Outer Carton
Quanyity:5000PCS

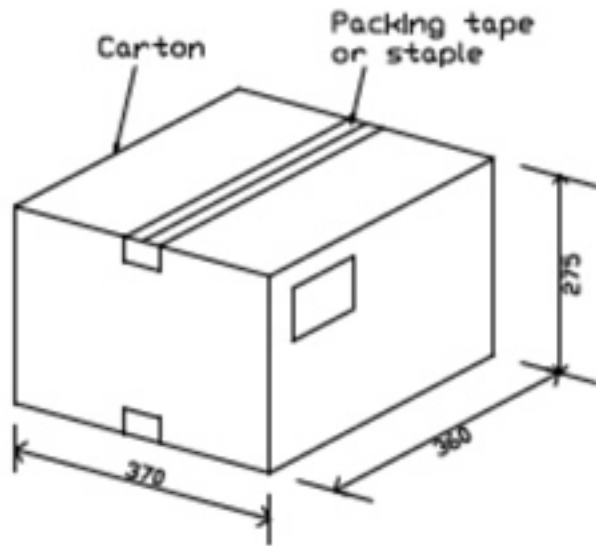

- 2. Inner Carton
Quanyity:1000PCS

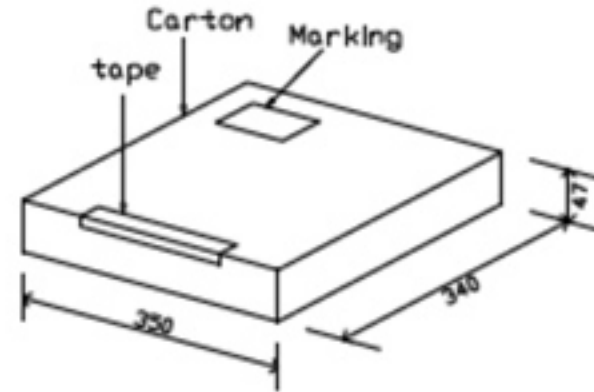

- 3. Bag
Quanyity:1000PCS

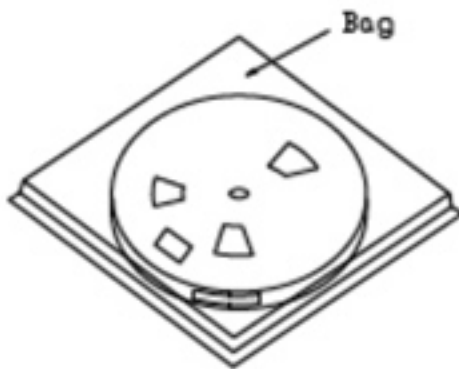

- 4. Taping
Quanyity:1000PCS

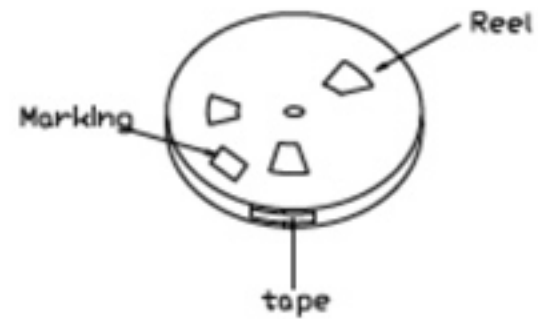

Unit:mm

F. Frequency Characteristics :

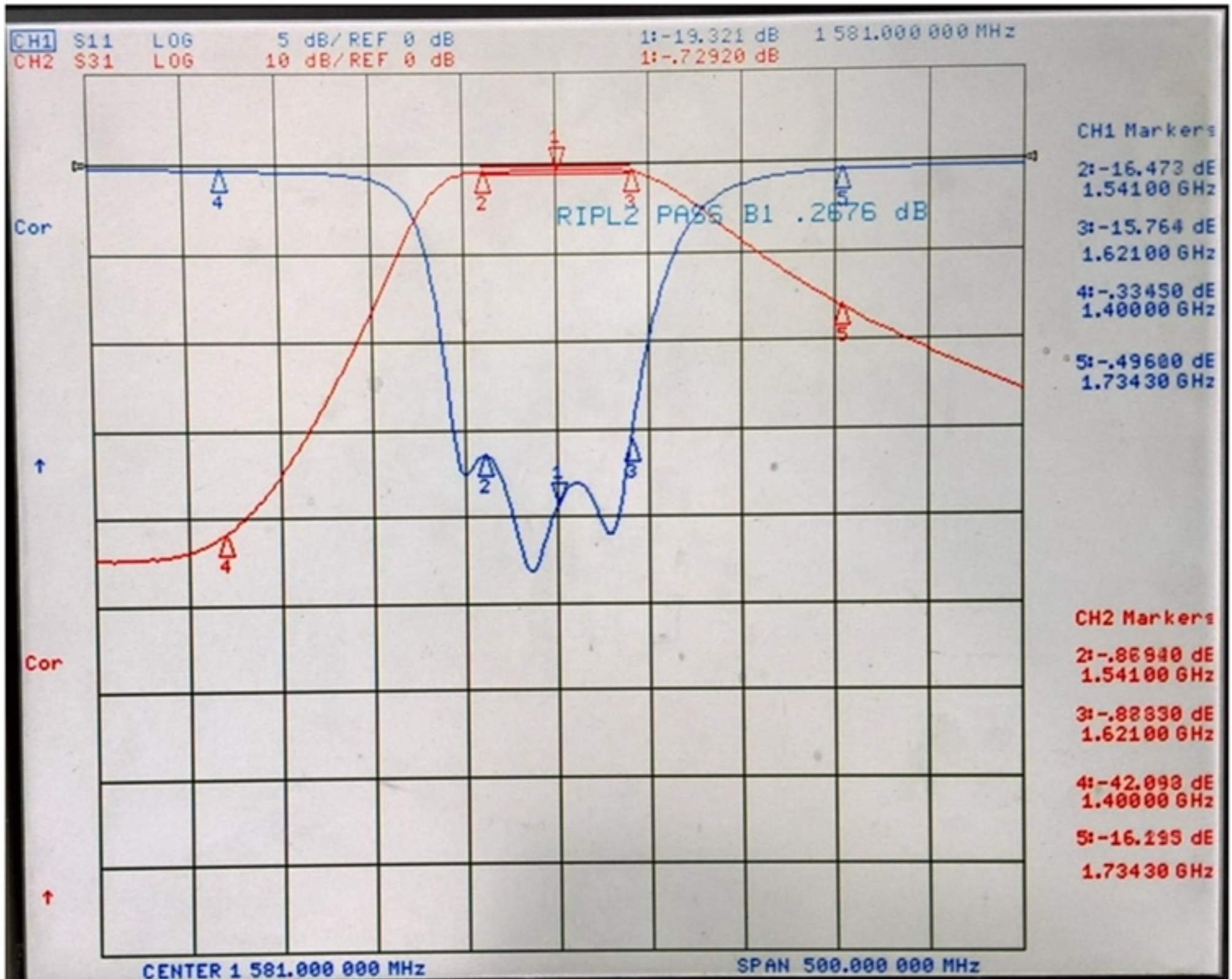

G. Recommended Reflow Profile:

Phase	Profile features	Pb-Free Assembly (SnAgCu)
PREHEAT	-Temperature Min(T_{smin}) -Temperature Max(T_{smax}) -Time(t_s) form (T_{smin} to T_{smax})	150°C 200°C 60-120 seconds
RAMP-UP	Avg. Ramp-up Rate (T_{smax} to TP)	3°C/second(max)
REFLOW	-Temperature(T_L) -Total Time above T_L (t_L)	217°C 30-100 seconds
PEAK	-Temperature(T_P) -Time(t_p)	260°C 3 second
RAMP-DOWN	Rate	6°C / second max.
Time from 25°C to Peak Temperature		8 minutes max.
Composition of solder paste		96.5Sn/3Ag/0.5Cu
Solder Paste Model		SHENMAO PF606-P26

Note : All the temperature measure point is on top surface of the component, if temperature over recommend, it will make component surface peeling or damage.

The graphic shows temperature profile for component assembly process in reflow ovens

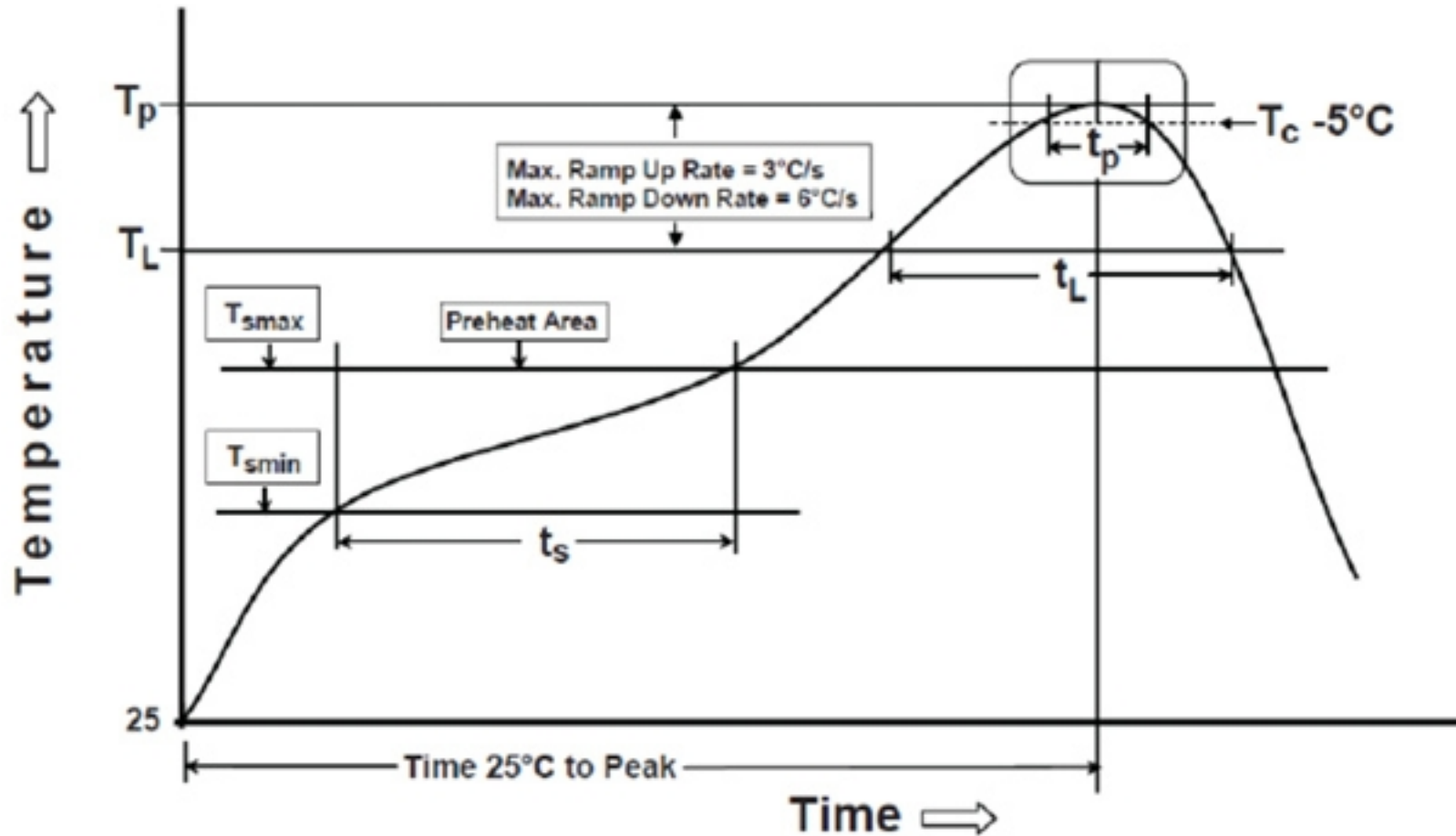

Soldering With Iron:

Soldering condition : Soldering iron temperature 270 ± 10 °C.

Apply preheating at 120°C for 2-3 minutes. Finish soldering for each terminal within 3 seconds, if soldering iron over temperature 270 ± 10 °C or 3 seconds, it will make component surface peeling or damage. Soldering iron can not leakage of electricity.