

SAW Filter 1747.5 MHz

MODEL NO.:TA1885A

REV. NO.:3.0

A. MAXIMUM RATING:

1. Input Power Level: 10 dBm (in passband)
2. DC Voltage : +/-5 V
3. Operating Temperature: -30 °C to +85 °C
4. Storage Temperature: -40 °C to +100 °C
5. Moisture Sensitive Level: Level 1 (MSL1)
6. ESD: 50 V(MM), 100 V(HBM)

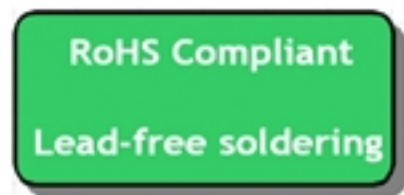

Electrostatic Sensitive Device (ESD)

B. ELECTRICAL CHARACTERISTICS:

Terminating source impedance: $Z_s = 50//7.5nH \Omega$

Terminating load impedance: $Z_L = 50//6.8nH \Omega$

Item	Unit	Min.	Typ.	Max.	Remark	
Center Frequency	Fc	MHz	-	1747.5	-	
Insertion Loss (1710~1785 MHz)	IL	dB(*1)	-	2.1	2.4	at 25 °C
		dB(*1)	-	-	3.0	-
Amplitude Ripple (1710~1785 MHz)		dB	-	1.0	1.5	at 25 °C
		dB	-	-	2.0	-
VSWR (1710~1785 MHz)		-	-	1.8	2.2	-
Attenuation (Reference level from 0 dB)						
DC ~ 1570 MHz	dB	25	36	-	-	
1570 ~ 1580 MHz	dB	35	41	-	-	
1805 ~ 1880 MHz	dB	15	22	-	at 25 °C	
	dB	10	-	-	-	
1930 ~ 2400 MHz	dB	25	34	-	-	
2400 ~ 3000 MHz	dB	15	32	-	-	
3000 ~ 4000 MHz	dB	10	27	-	-	
4000 ~ 6000 MHz	dB	5	21	-	-	

(*1) Specification of insertion loss includes loss that comes from test board. (Approximately 0.15 dB)

C. FREQUENCY CHARACTERISTICS:

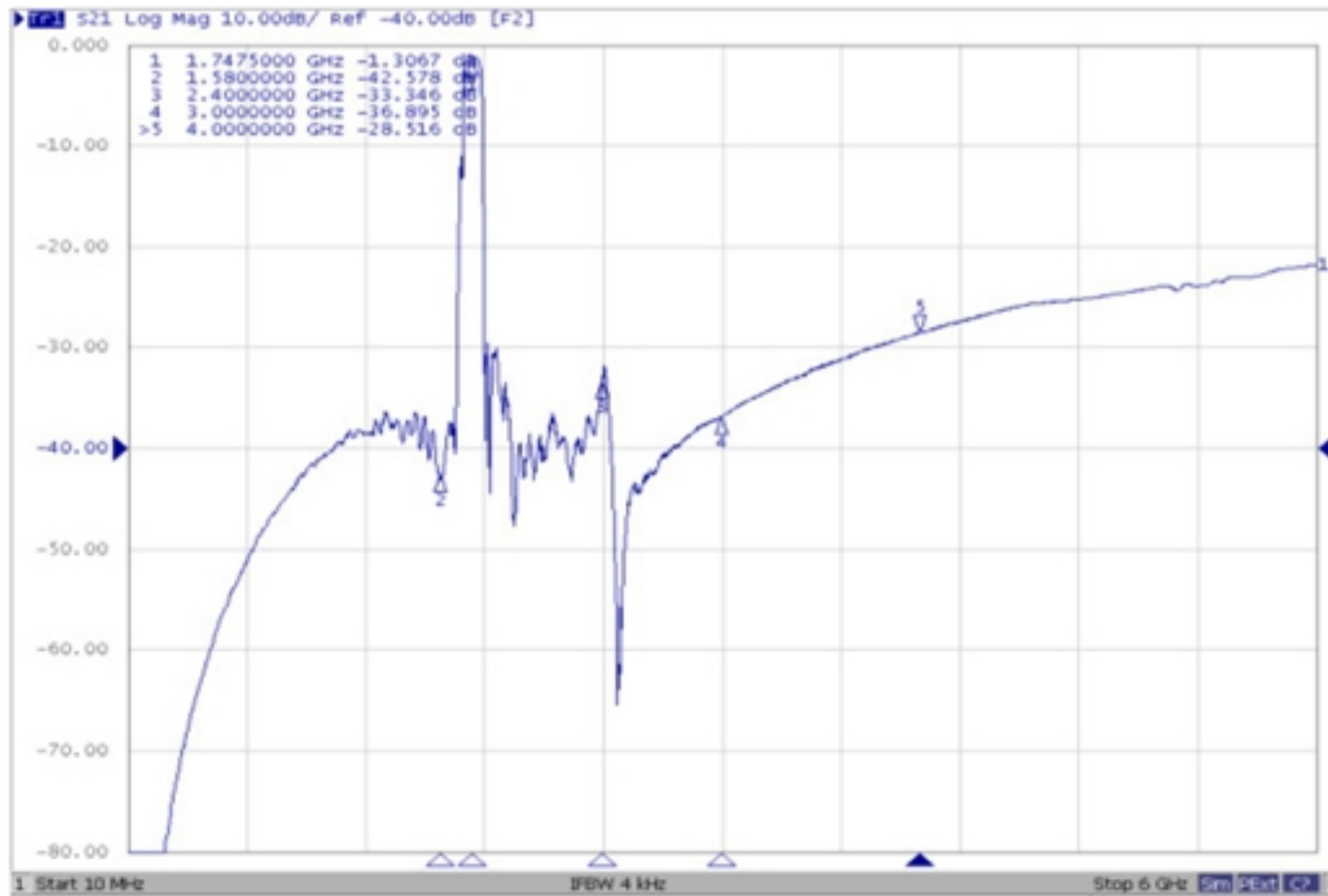
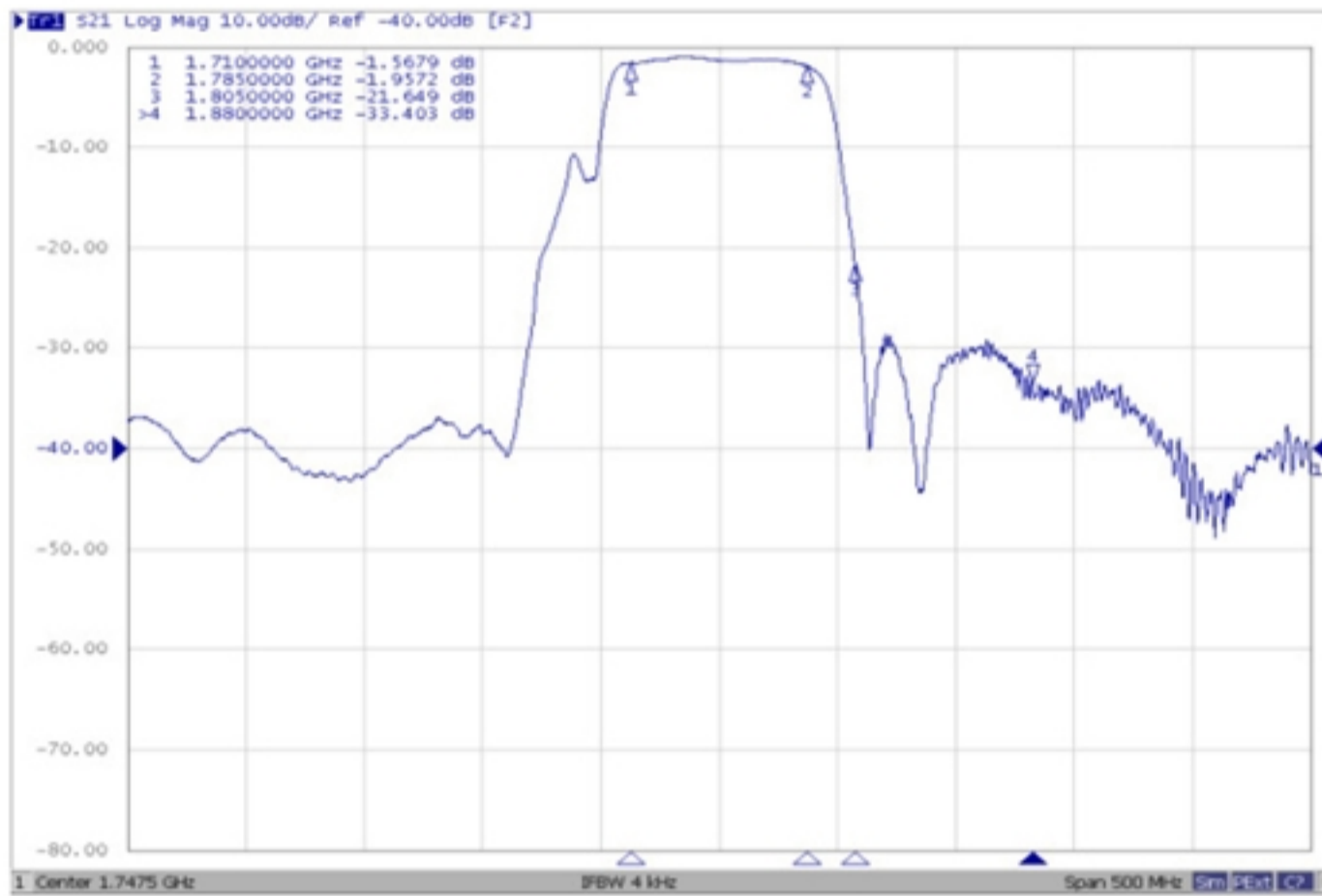
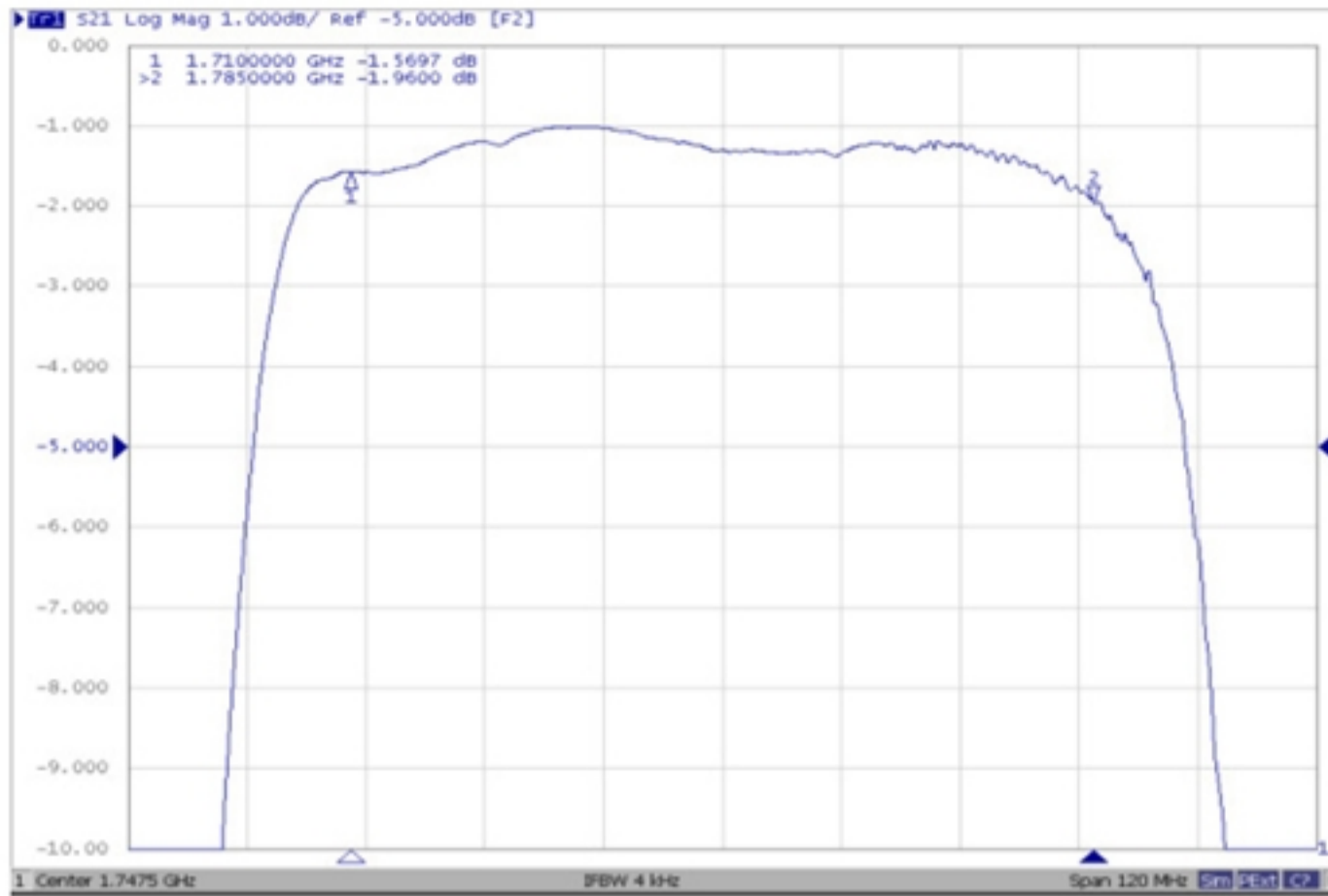

Reflection Functions:

VSWR

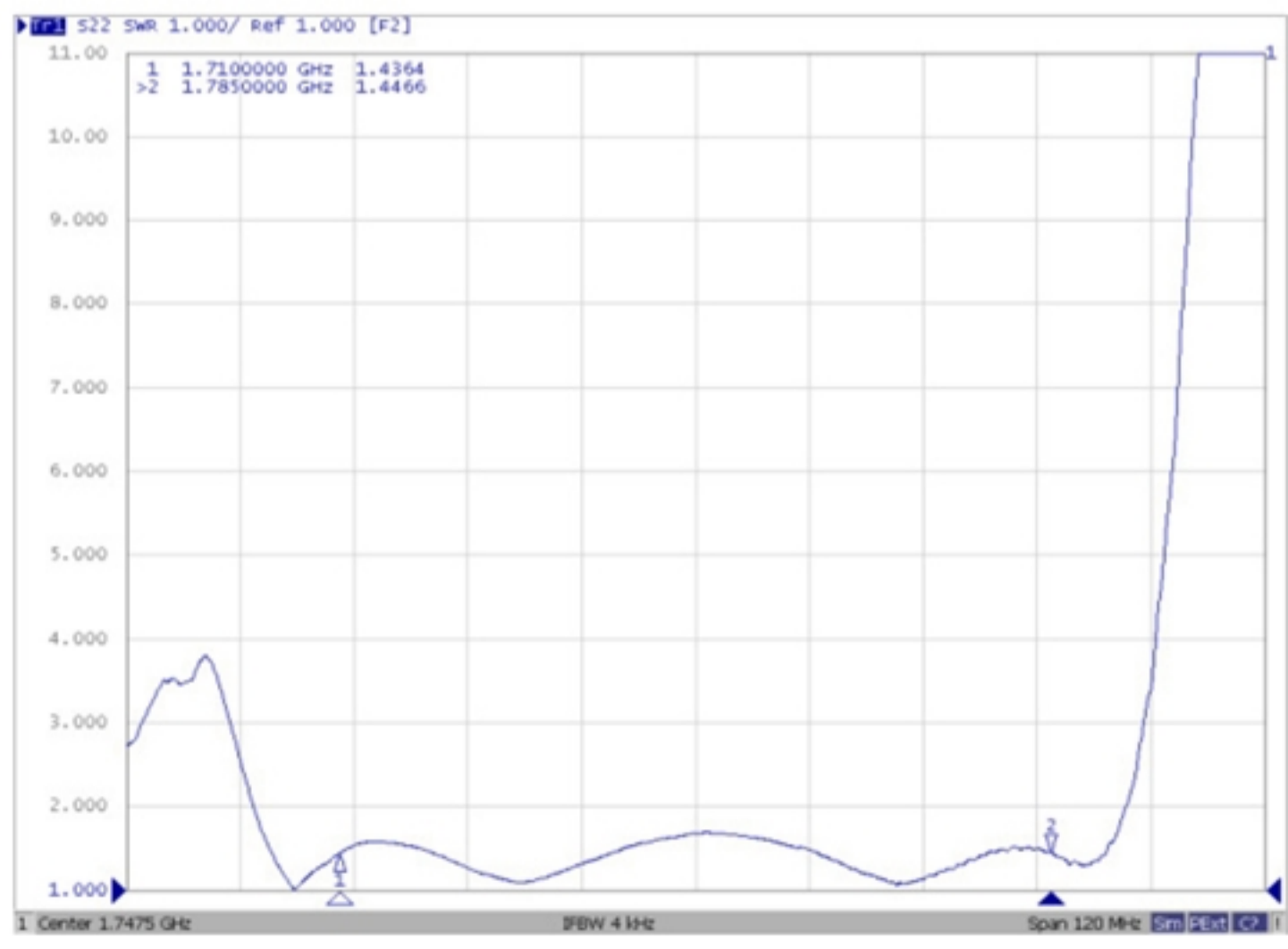
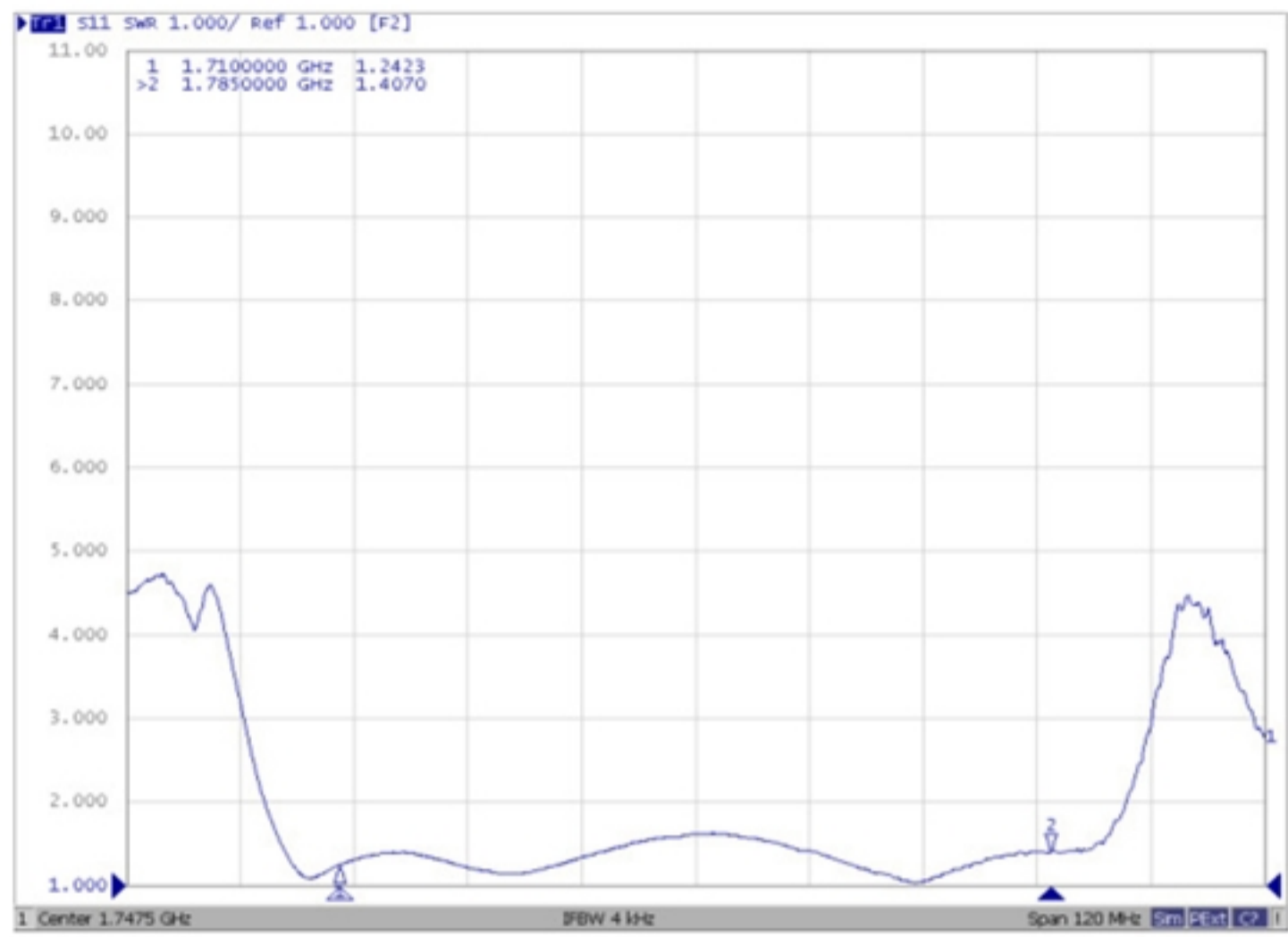

Smith Chart

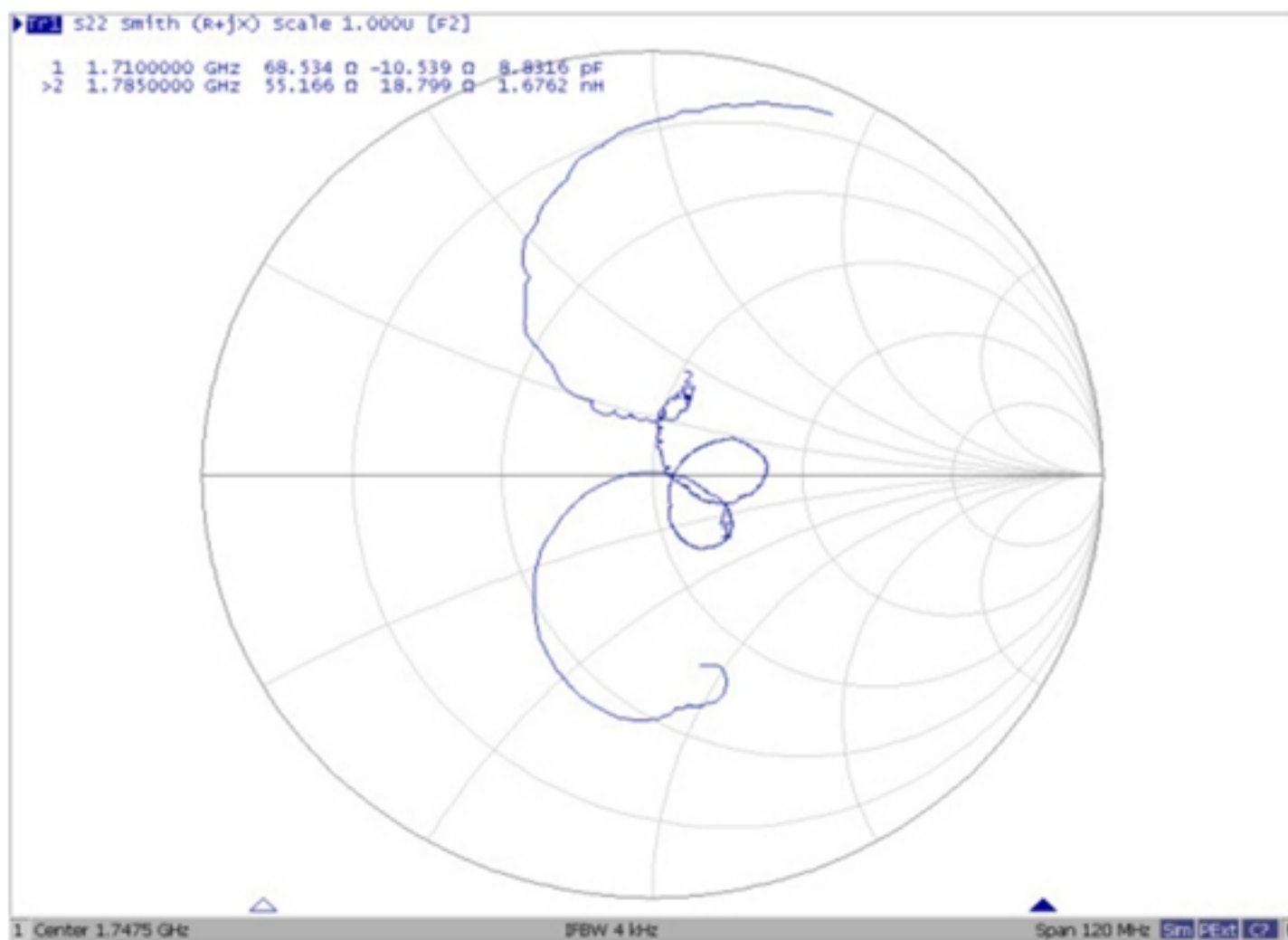
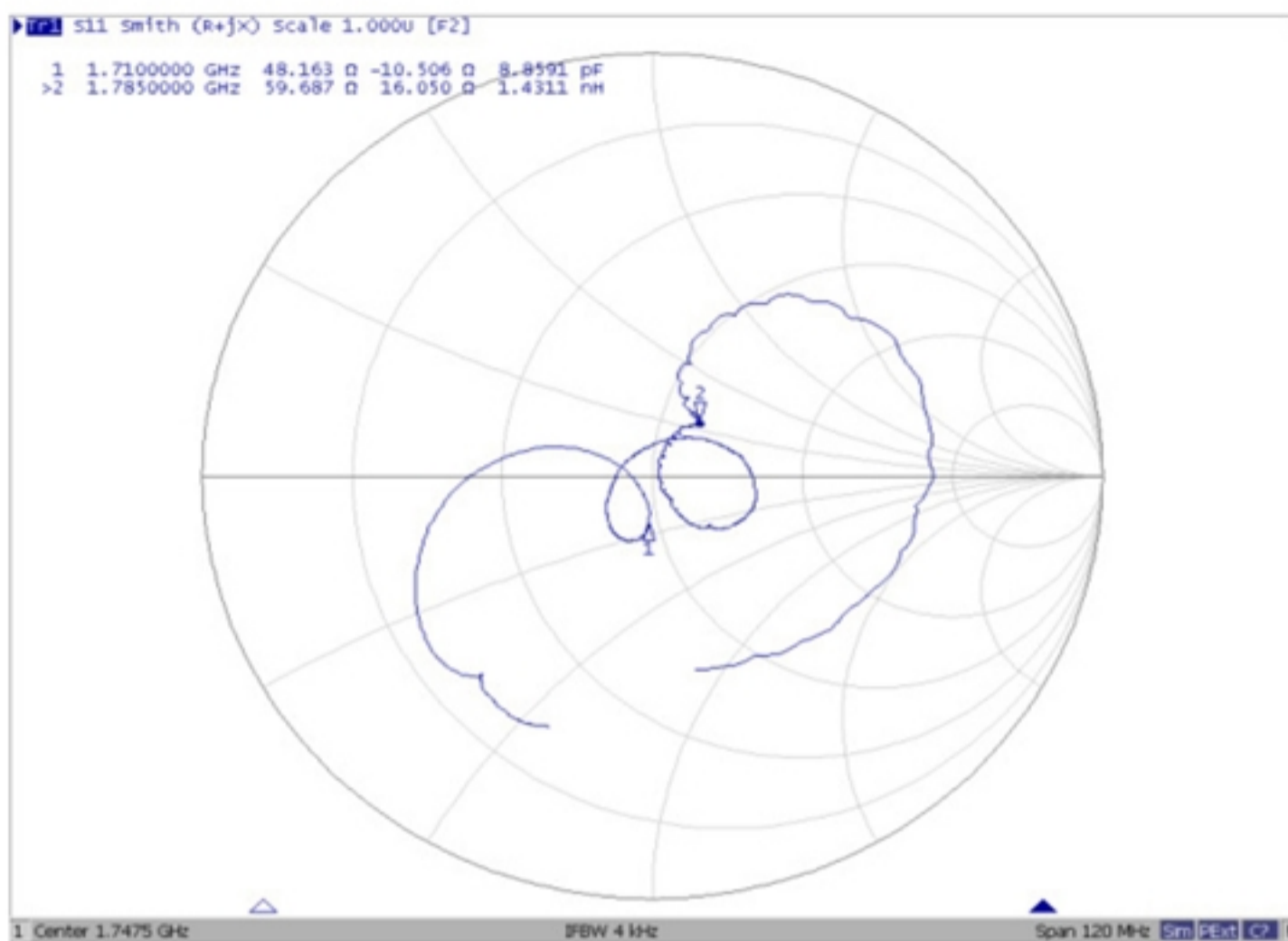

D. MEASUREMENT CIRCUIT:

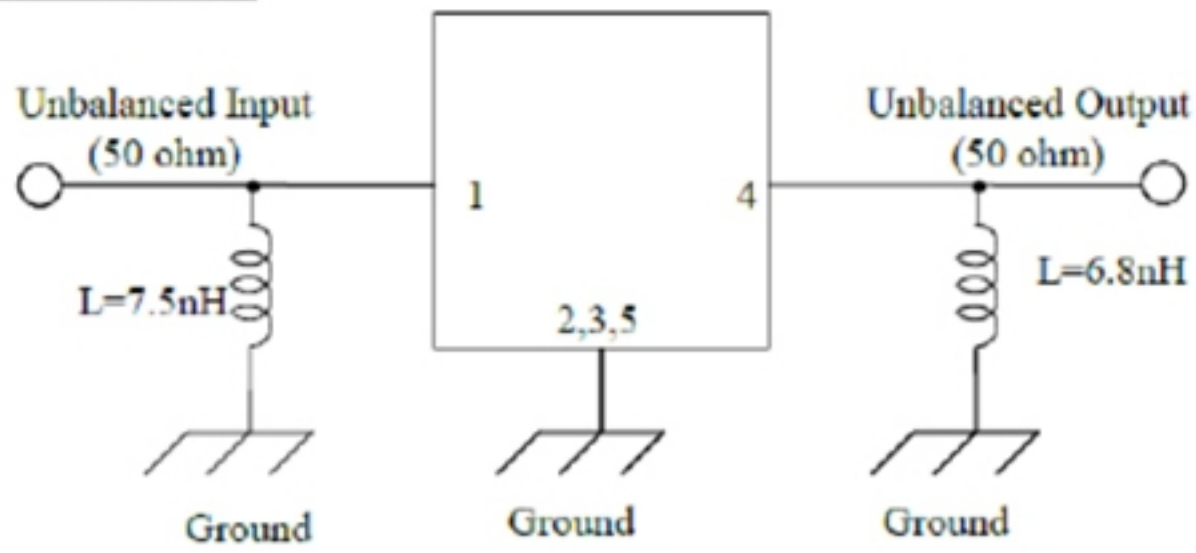

E. PCB Footprint:

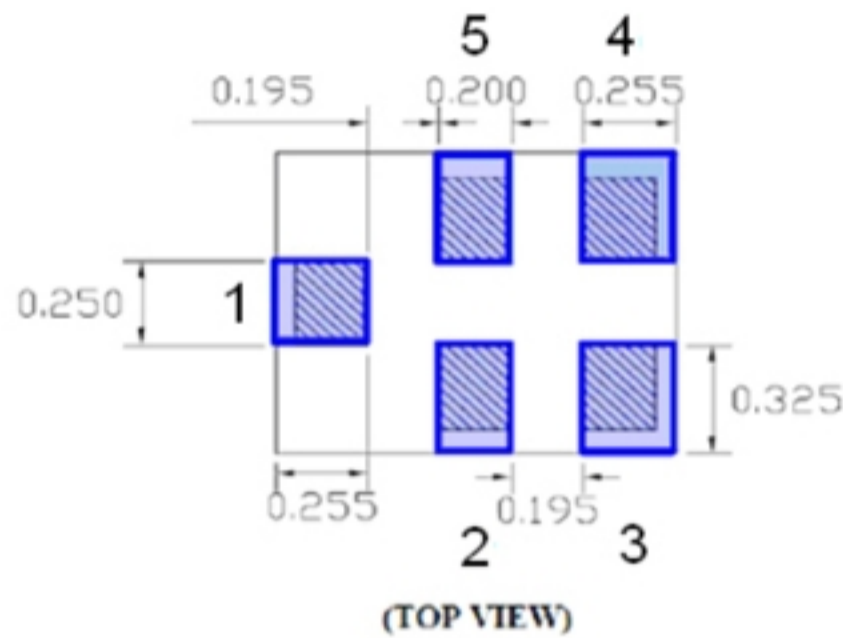

F. OUTLINE DRAWING:

Device size: 1.1typ. x 0.9typ. x 0.5max.

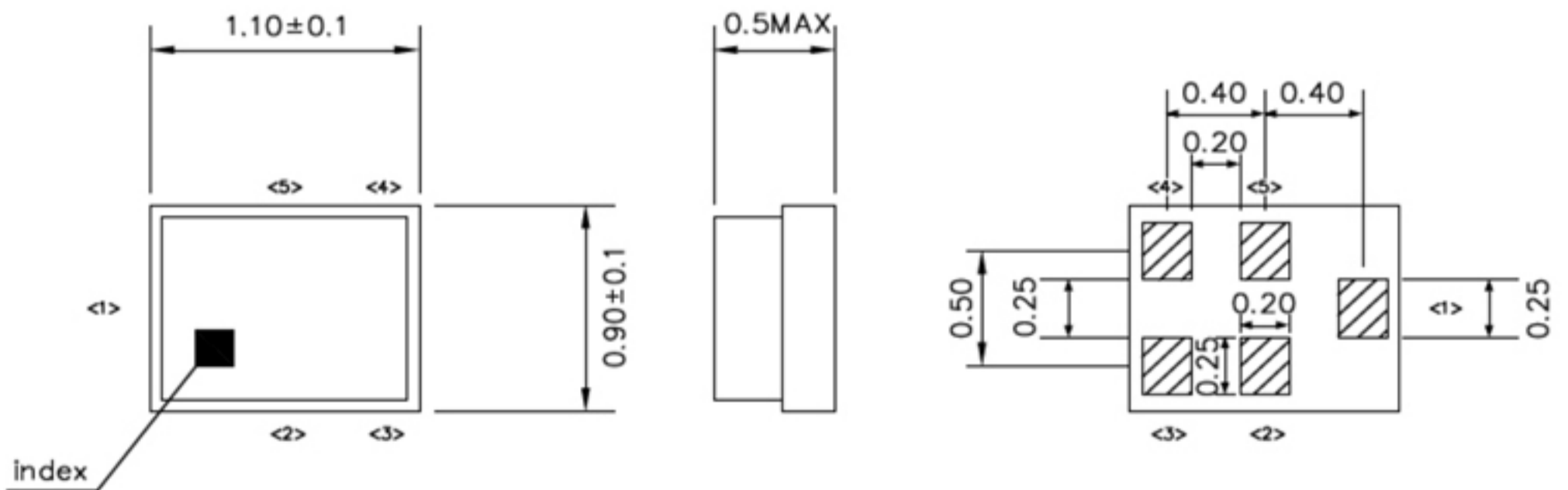

Unit : mm

Pin Configuration

Pin No.	Symbol	Function
1	IN	Unbalanced pin
2	GND	Ground
3	GND	Ground
4	OUT	Unbalanced pin
5	GND	Ground

Top View (Sample Production):



Top View (Mass Production):

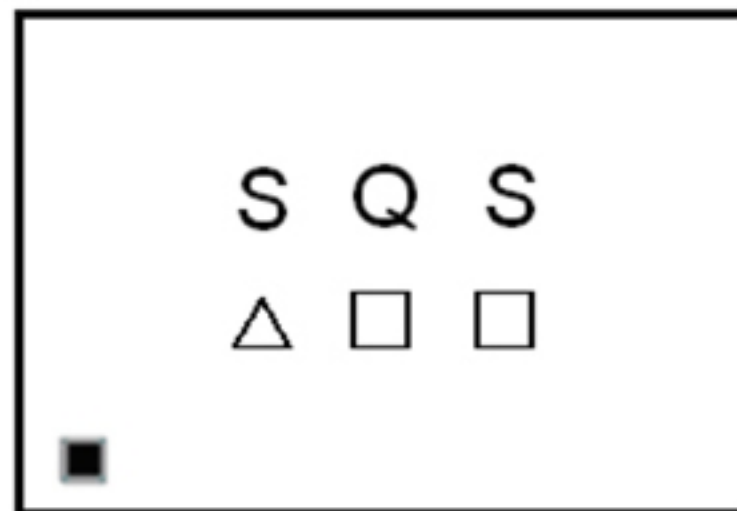

△ : **Date Code**

□ : **Lot No. (Indicated by 0~9 or A to Z and a to z, except I, O, i, o and l)**

Date Code:

Year	Jan.	Feb.	Mar.	Apr.	May.	Jun.	Jul.	Aug.	Sep.	Oct.	Nov.	Dec.
2015	a	b	c	d	e	f	g	h	j	k	l	m
2016	n	p	q	r	s	t	u	v	w	x	y	z
2017	A	B	C	D	E	F	G	H	J	K	L	M
2018	N	P	Q	R	S	T	U	▽	W	X	Y	Z

G. PACKING: (Ref: WI-75M03)

1. REEL DIMENSION

(Please refer to FR-75D10 for packing quantity)

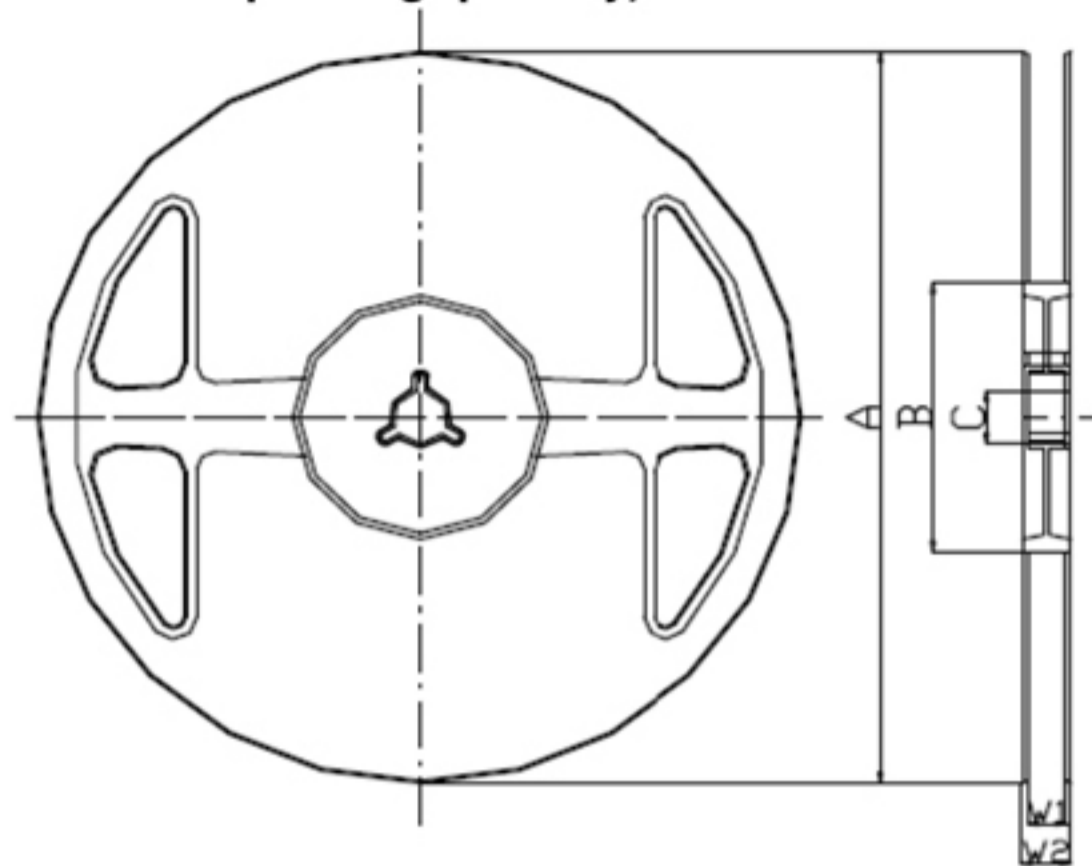

Materials of Reel

Material : Polystyrene + Carbon

Color : Black

Surface resistance (reference value) : $10^9 \Omega/\text{sq}$ Max.

Unit : mm

A	B	C	W1	W2
$\phi 180.0 +0.0/-1.5$	$\phi 66.0 +/-0.5$	$\phi 13.0 +/-0.2$	$9.0 +1.0/-0.0$	$11.4 +/-1.0$

2. TAPE DIMENSION

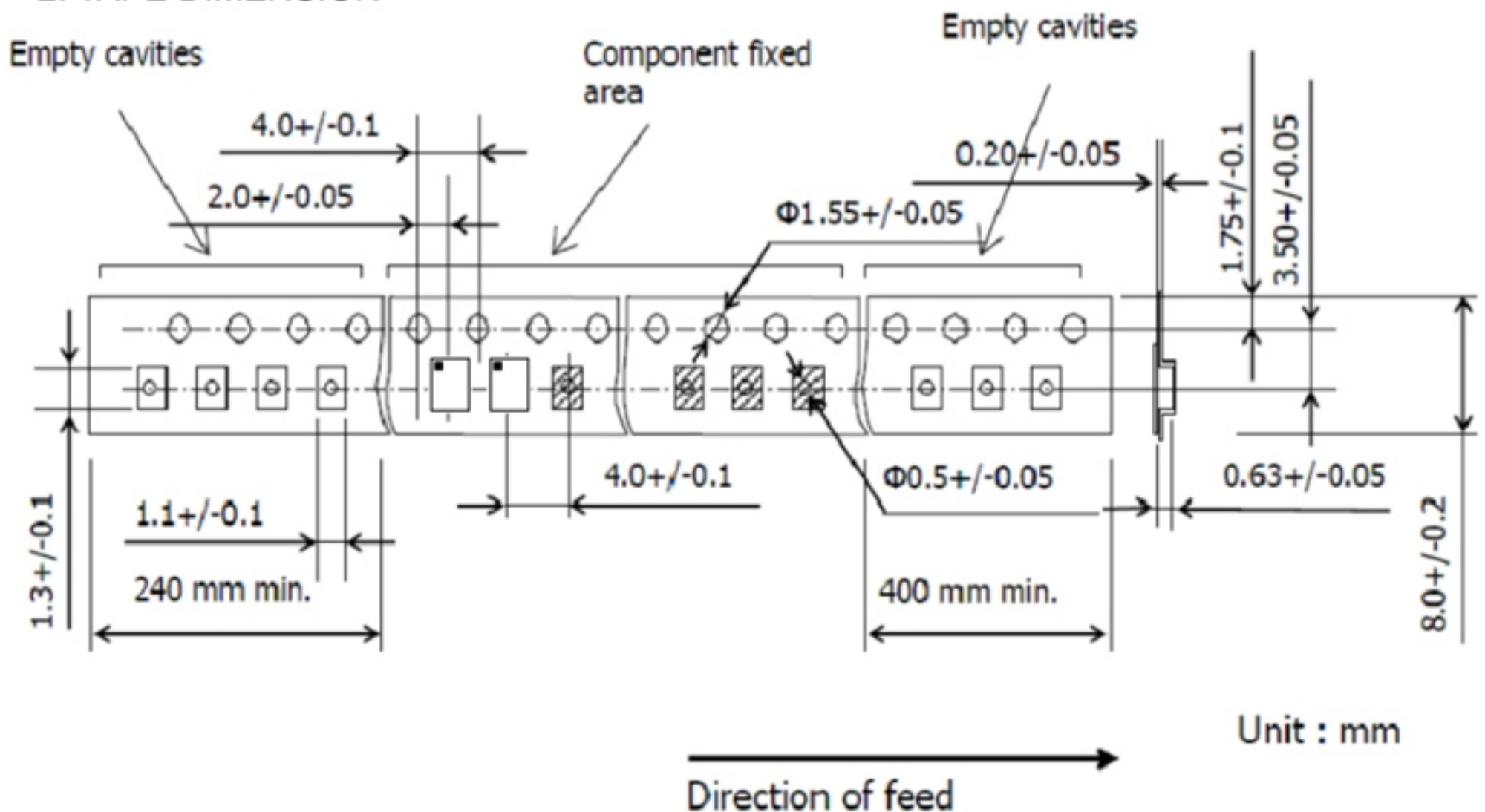

Unit : mm

H. Recommended Reflow Profile:

1. Preheating shall be fixed at $150\sim 180^{\circ}\text{C}$ for 60~90 seconds.
2. Ascending time to preheating temperature 150°C shall be 30 seconds min.
3. Heating shall be fixed at 220°C for 50~80 seconds and at $260^{\circ}\text{C} +0/-5^{\circ}\text{C}$ peak (20~40sec).
4. Time: 2 times.

