

SAW Filter 1842.5 MHz

MODEL NO.:TA1843DN1224

REV.1.0

A. MAXIMUM RATING:

1. Maximum Input Power: 10 dBm
2. DC Voltage: 0 V
3. Operating Temperature: -20 °C to +85 °C
4. Storage Temperature Range: -40 °C to +85 °C
5. Moisture Sensitive Level: Level 3 (MSL 3)
6. ESD: 50 V(MM), 100 V(HBM)

RoHS Compliant

Lead-free soldering

Electrostatic Sensitive Device (ESD)

B. ELECTRICAL CHARACTERISTICS:

Terminating source impedance: $Z_s = 50//33\text{nH } \Omega$ (Single-ended)

Terminating load impedance: $Z_L = 50//12\text{nH } \Omega$ (Single-ended)

Item		Unit	Min.	Typ.	Max.	
Center Frequency		MHz	-	1842.5	-	
Insertion Loss (*1)		1805 ~ 1880 MHz	dB	-	2.0	4.0
Amplitude Ripple		1805 ~ 1880 MHz	dB _{p-p}	-	1.0	3.3
VSWR	Input	1805 ~ 1880 MHz	-	-	1.7	2.3
	Output	1805 ~ 1880 MHz	-	-	1.6	2.2
Attenuation (Reference level from 0 dB)						
DC ~ 960 MHz		dB	32	35	-	
1558 ~ 1608 MHz		dB	32	36	-	
1710 ~ 1785 MHz		dB	34	38	-	
1920 ~ 2400 MHz		dB	25	37	-	
2400 ~ 2500 MHz		dB	33	39	-	
2500 ~ 3610 MHz		dB	25	35	-	
3610 ~ 3760 MHz		dB	25	38	-	
3760 ~ 5415 MHz		dB	20	35	-	
5415 ~ 5640 MHz		dB	20	36	-	
5640 ~ 7220 MHz		dB	18	27	-	
7220 ~ 7520 MHz		dB	16	25	-	
7520 ~ 8000 MHz		dB	14	23	-	

(*1) Specification of insertion loss excludes loss that comes from the test board.

C. EFREQUENCY CHARACTERISTICS:

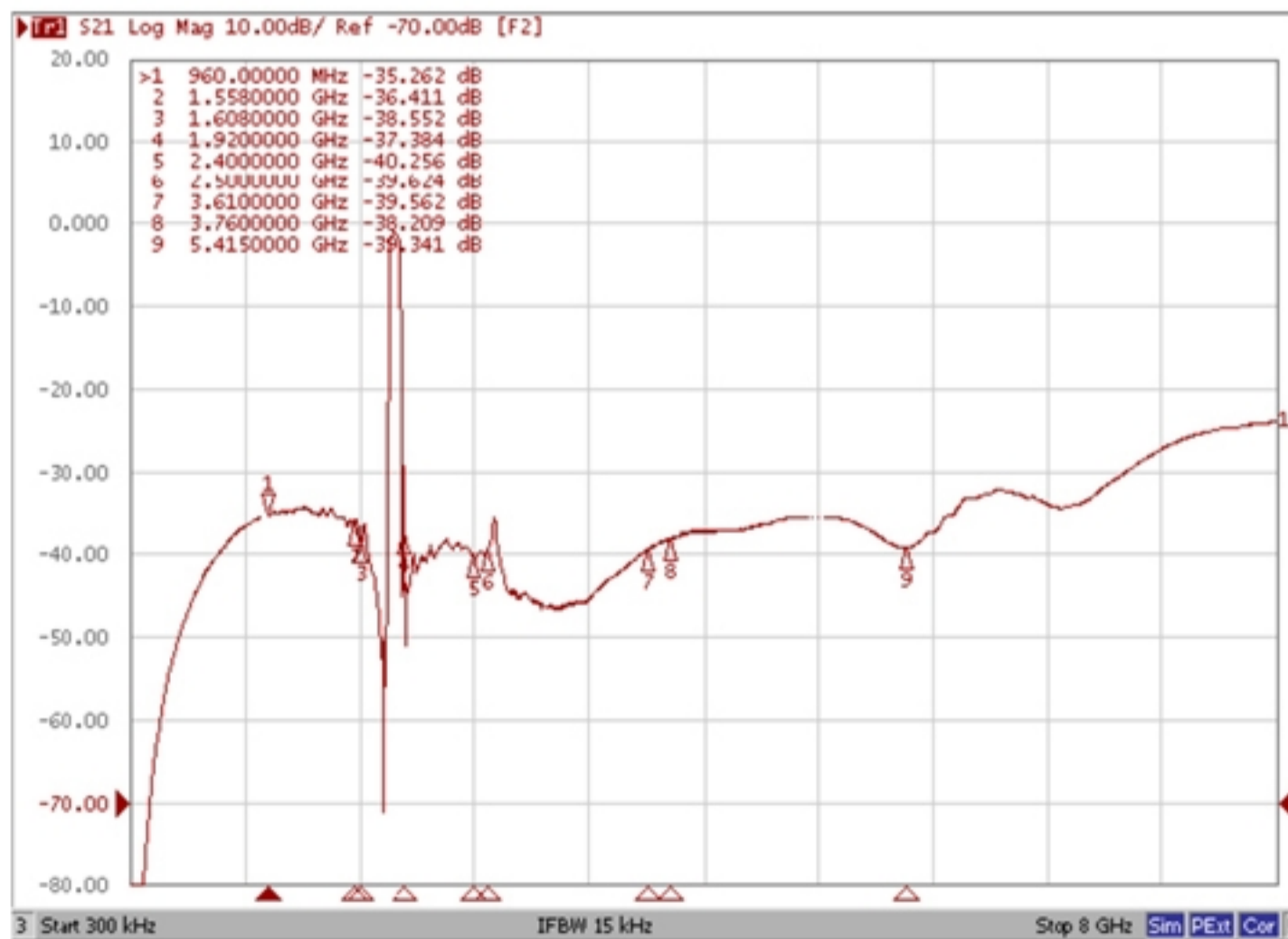

Reflection Functions:

VSWR

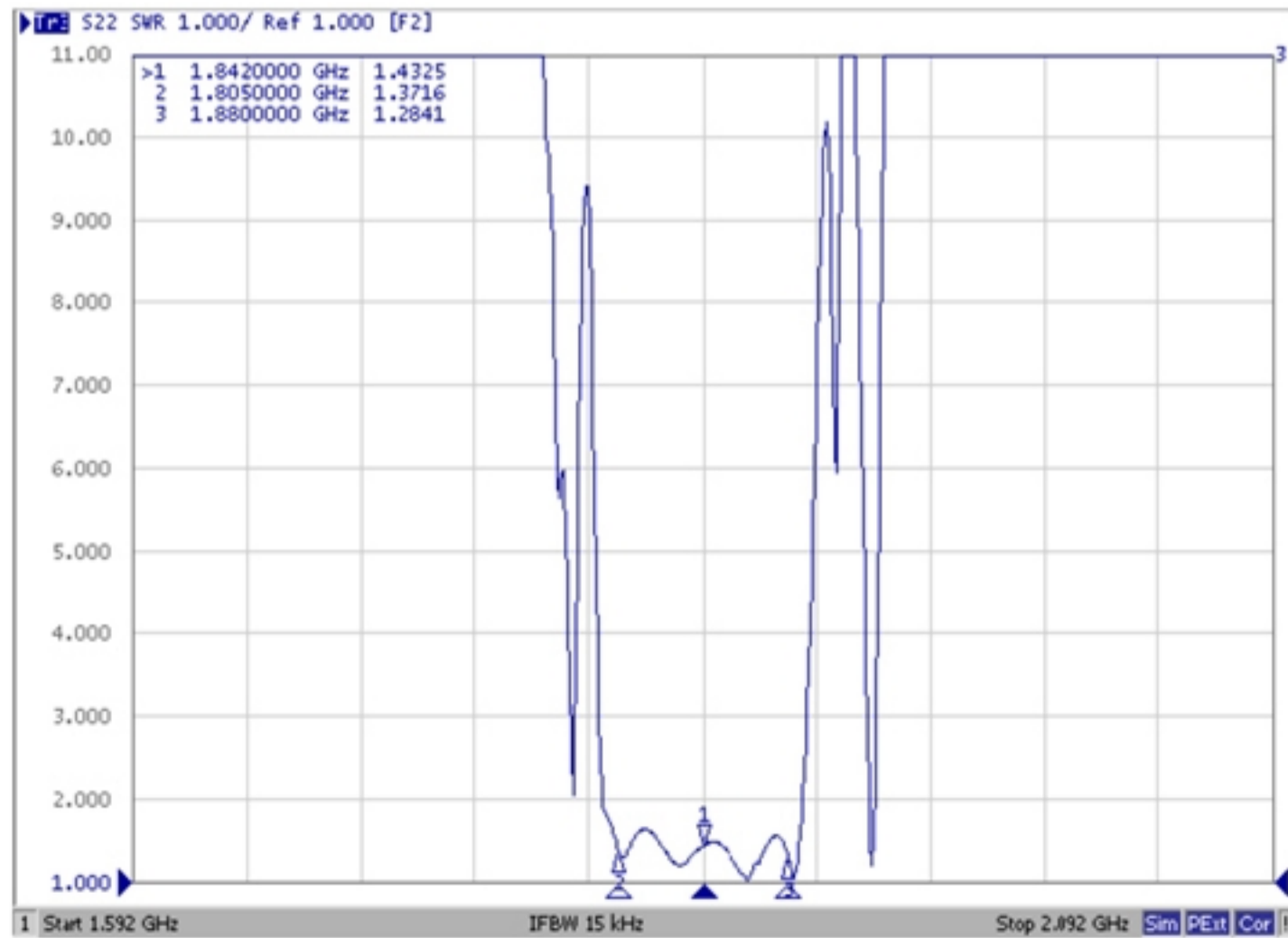
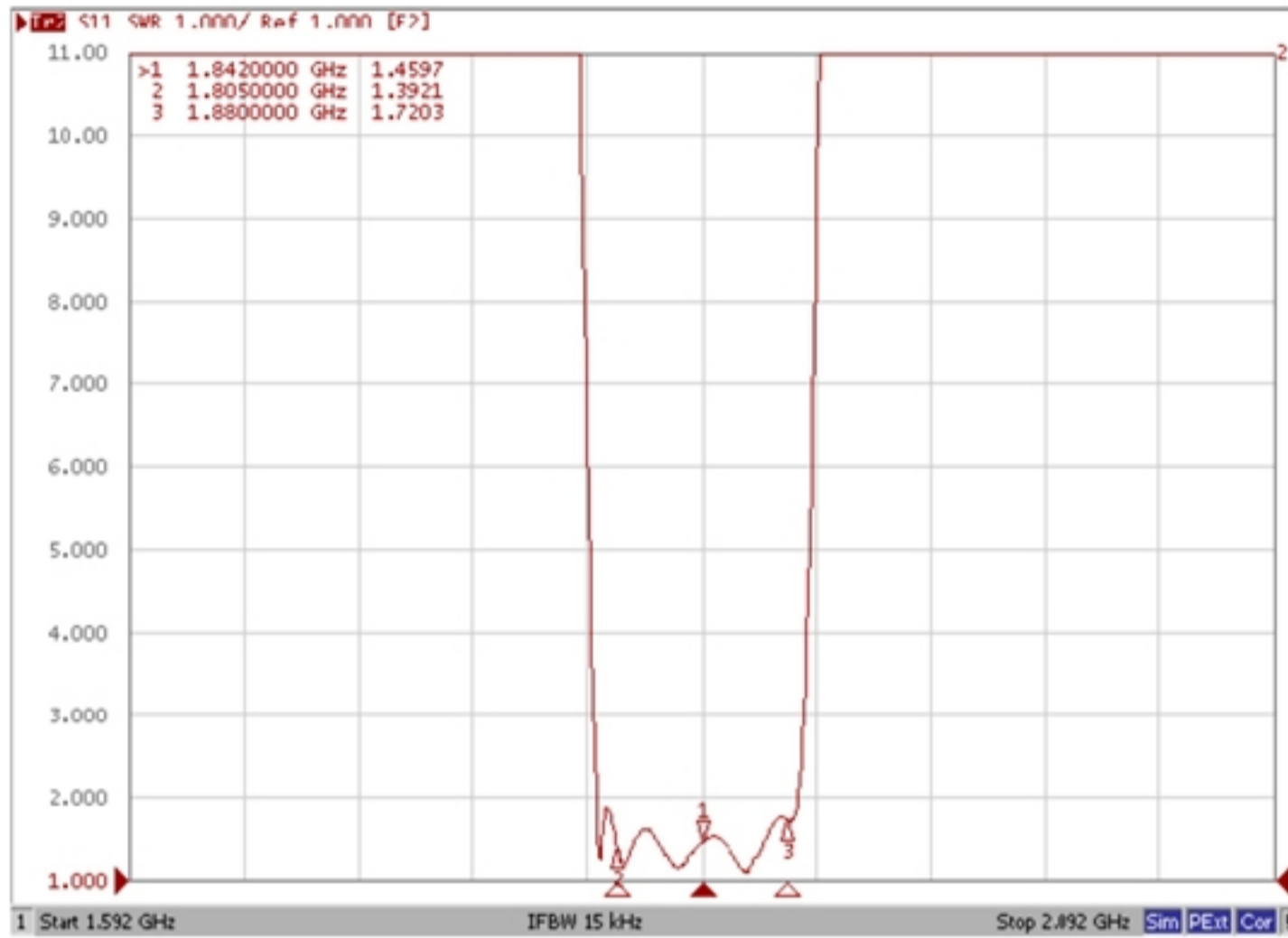

Smith Chart

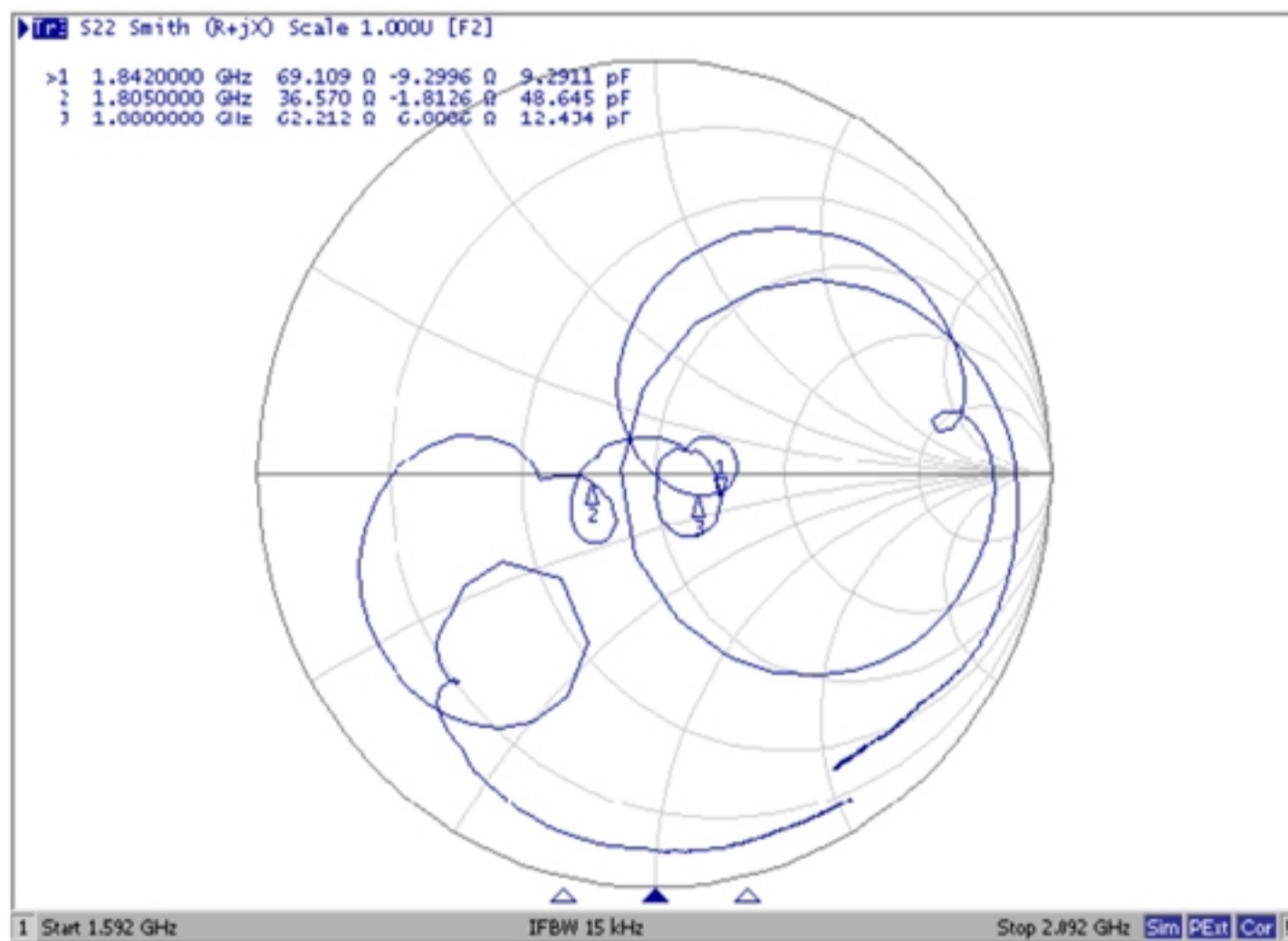
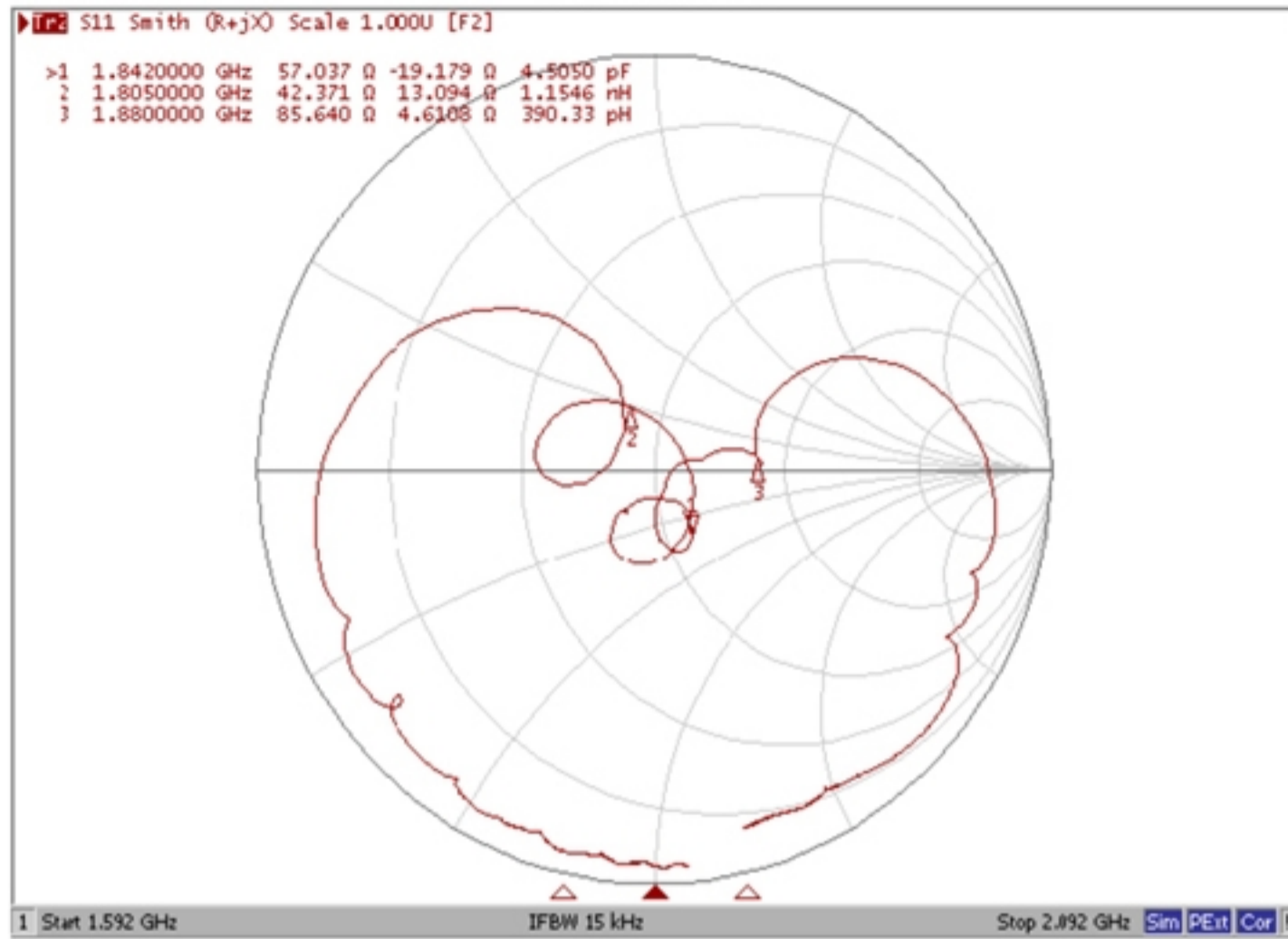

D. MEASUREMENT CIRCUIT:

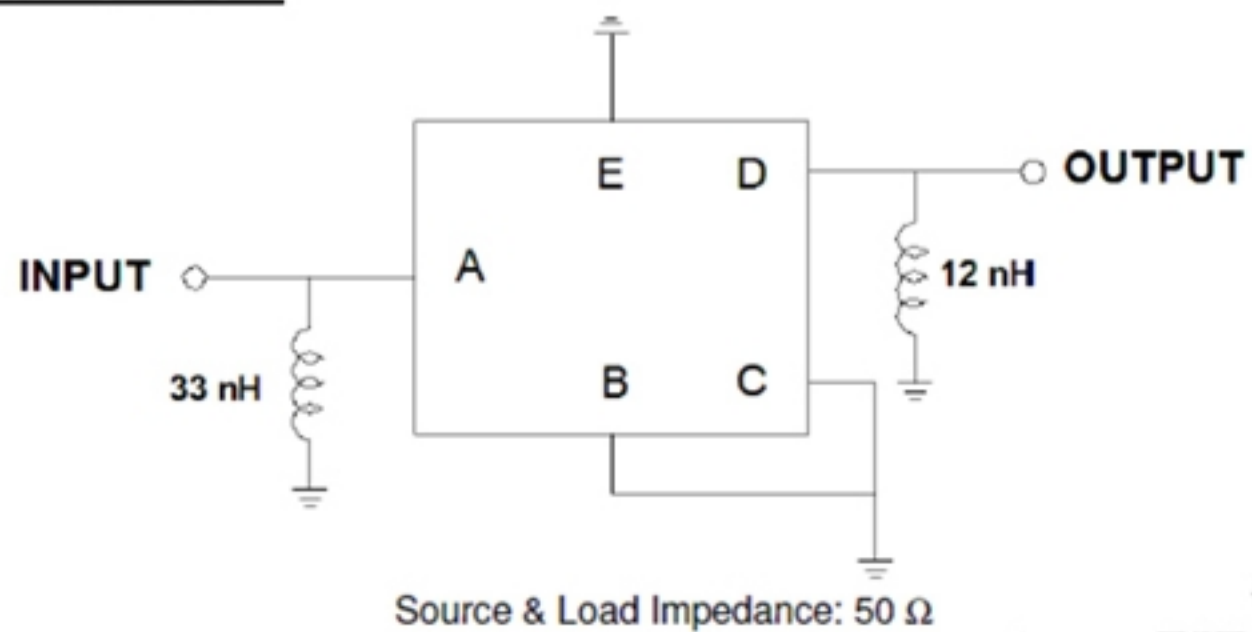

E. OUTLINE DRAWING:

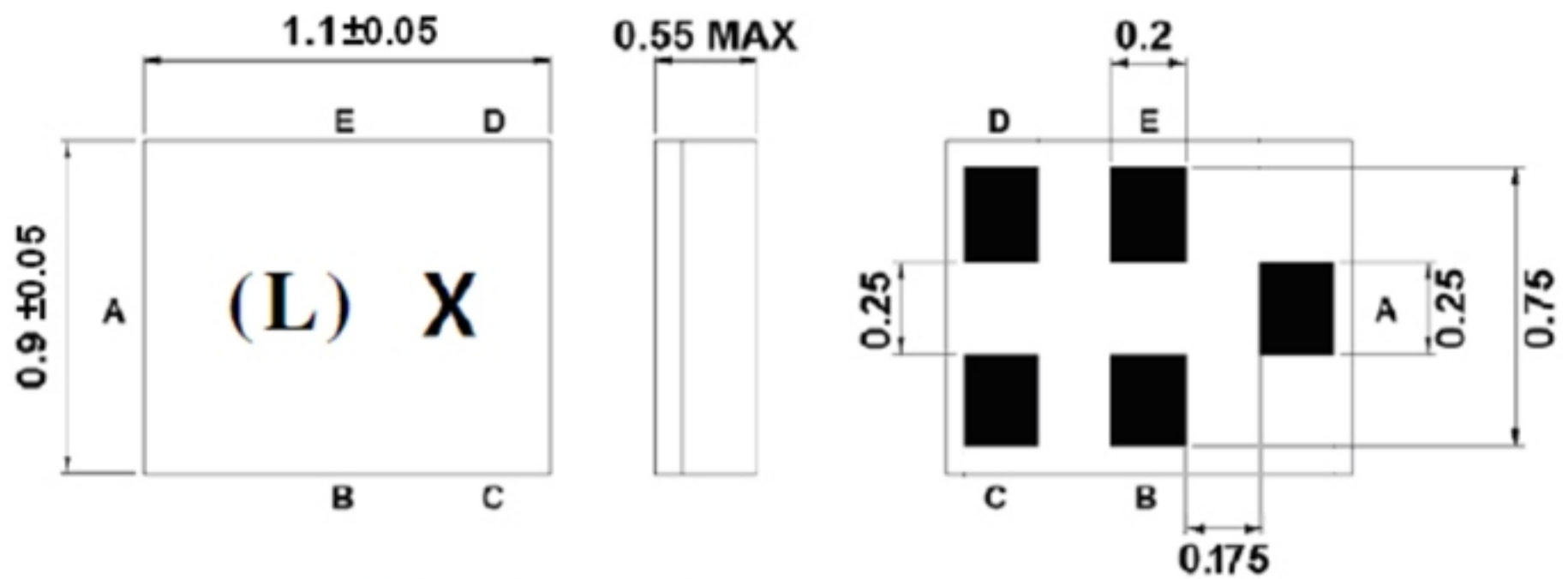

Pin Description	
B, C, E	Ground
A	Input
D	Output

All tolerances are ± 0.05 mm unless otherwise specified.
Unit: mm

Marking Descriptions:

(L) : Series Number

X : Year/Month Code (Follow the table)

Year/Month Code

Year/Month	1	2	3	4	5	6	7	8	9	10	11	12
2020	<u>n</u>	<u>p</u>	<u>q</u>	<u>r</u>	<u>s</u>	<u>t</u>	<u>u</u>	<u>v</u>	<u>w</u>	<u>x</u>	<u>y</u>	<u>z</u>
2021	A	B	C	D	E	F	G	H	J	K	L	M
2022	N	P	Q	R	S	T	U	V	W	X	Y	Z
2023	a	b	c	d	e	f	g	h	j	k	l	m
2024	n	p	q	r	s	t	u	v	w	x	y	z
2025	<u>A</u>	<u>B</u>	<u>C</u>	<u>D</u>	<u>E</u>	<u>F</u>	<u>G</u>	<u>H</u>	<u>J</u>	<u>K</u>	<u>L</u>	<u>M</u>
2026	<u>N</u>	<u>P</u>	<u>Q</u>	<u>R</u>	<u>S</u>	<u>T</u>	<u>U</u>	<u>V</u>	<u>W</u>	<u>X</u>	<u>Y</u>	<u>Z</u>
2027	<u>a</u>	<u>b</u>	<u>c</u>	<u>d</u>	<u>e</u>	<u>f</u>	<u>g</u>	<u>h</u>	<u>j</u>	<u>k</u>	<u>l</u>	<u>m</u>

F. PCB FOOTPRINT:

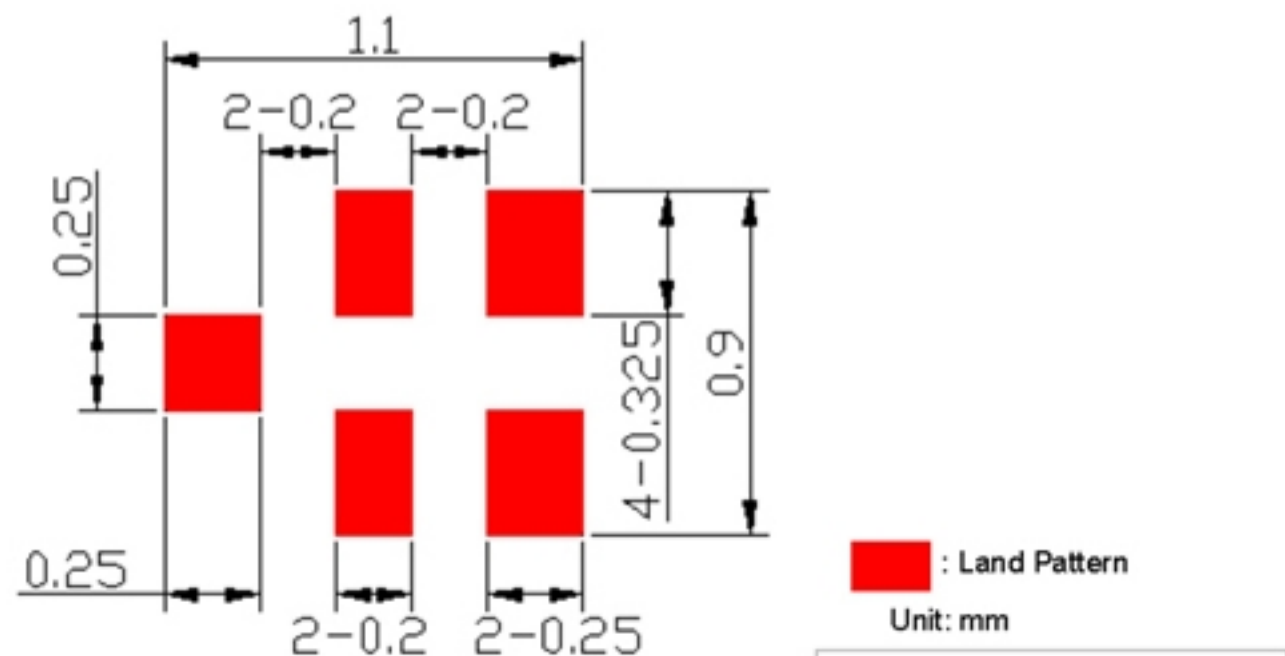

■ : Land Pattern
Unit: mm

G. PACKING: (Ref: WI-75M03)

1. REEL DIMENSION

(Please refer to FR-75D10 for packing quantity)

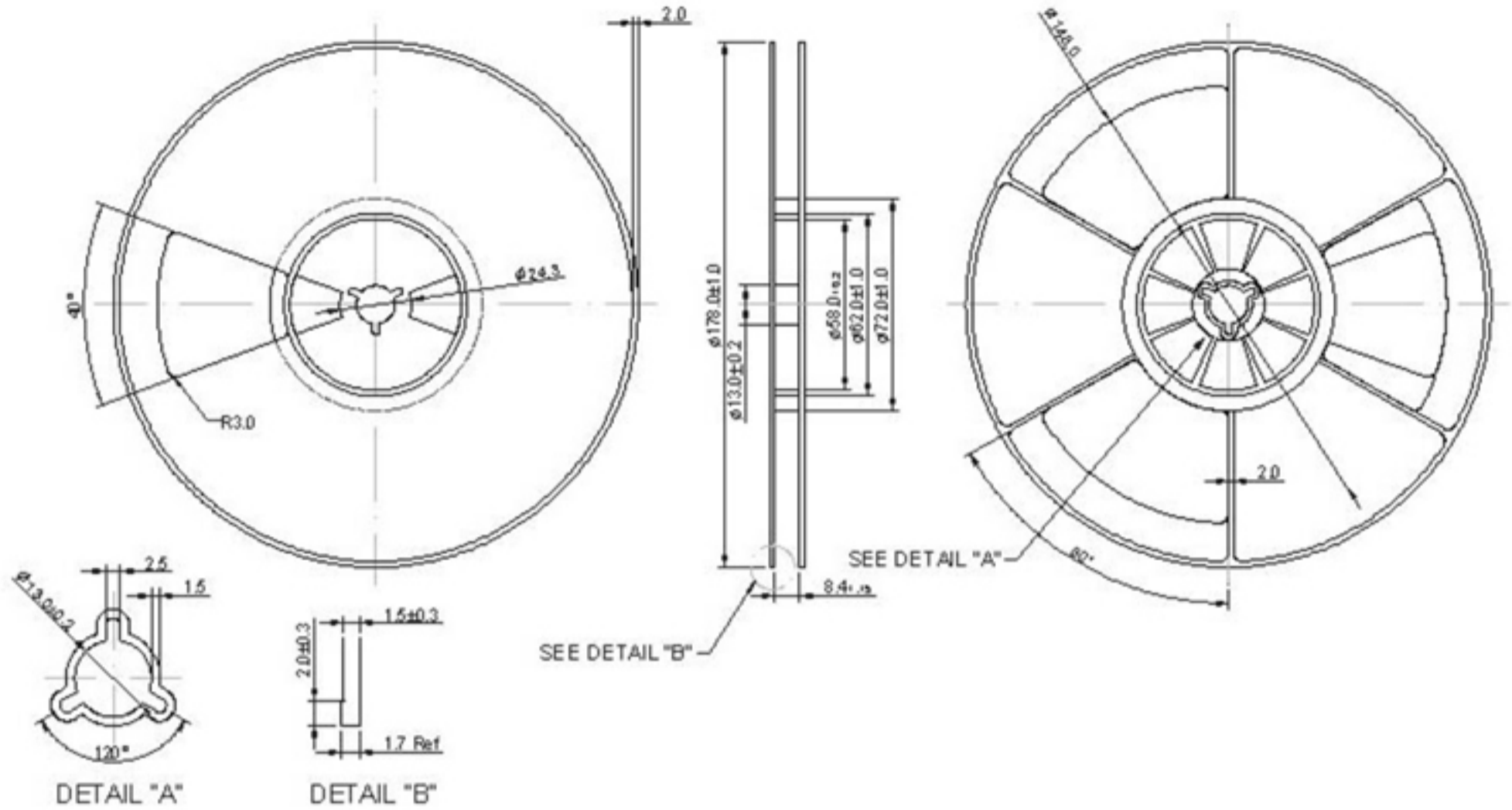

2. TAPE DIMENSION

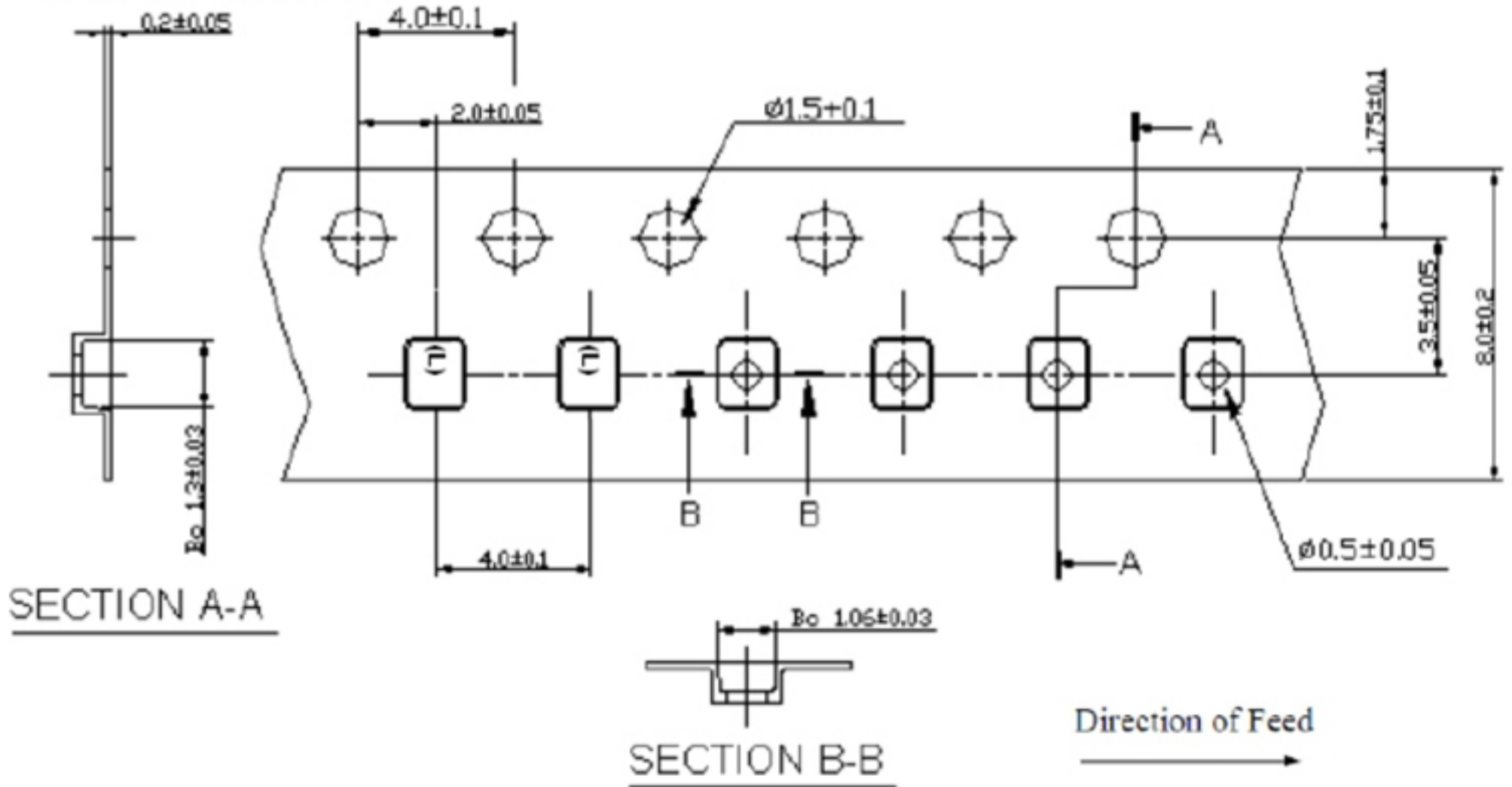

H. RECOMMENDED REFLOW PROFILE:

1. Preheating shall be fixed at $150\sim 180^{\circ}\text{C}$ for 60~90 seconds.
2. Ascending time to preheating temperature 150°C shall be 30 seconds min.
3. Heating shall be fixed at 220°C for 50~80 seconds and at $260^{\circ}\text{C} + 0/-5^{\circ}\text{C}$ peak (20~40sec).
4. Time: 2 times.

