

SAW Filter 1880MHz

MODEL NO.:TA2628A

REV. NO.:1.0

A. MAXIMUM RATING:

1. Input Power Level: 10 dBm
2. DC Voltage : 0V
3. Operating Temperature: -30 °C to +85 °C
4. Storage Temperature: -40 °C to +85 °C
5. Moisture Sensitivity Level: Level 3(MSL3)



Electrostatic Sensitive Device (ESD)

B. ELECTRICAL CHARACTERISTICS:

Terminating source impedance (single) : $Z_s = 50 \Omega$

Terminating load impedance(single) : $Z_L = 50 \Omega$

Item	Unit	Min	Type.	Max	Note
Center Frequency Fc	MHz	-	1880	-	
Insertion Loss (1850.6~1909.4 MHz) IL	dB		2.4	3.8	
Amplitude ripple (1850.6~1909.4 MHz)			1.3	2.7	
VSWR (1850.6~1909.4 MHz)			2.0	2.5	
Attenuation					
DC ~ 1570 MHz	dB	20	25		
1570 ~ 1580 MHz	dB	24	28		
1580 ~ 1770 MHz	dB	24	28		
1770 ~ 1829.4 MHz	dB	10	23		
1930.6 ~ 1989.4 MHz	dB	27	35		23~ 27°C
1989.4 ~ 3000 MHz	dB	23	28		
3000 ~ 4000 MHz	dB	14	21		
4000 ~ 6000 MHz	dB	4	9		
Package size	mm	1411			

C.OUTLINE DRAWING:

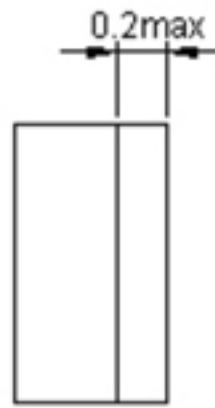
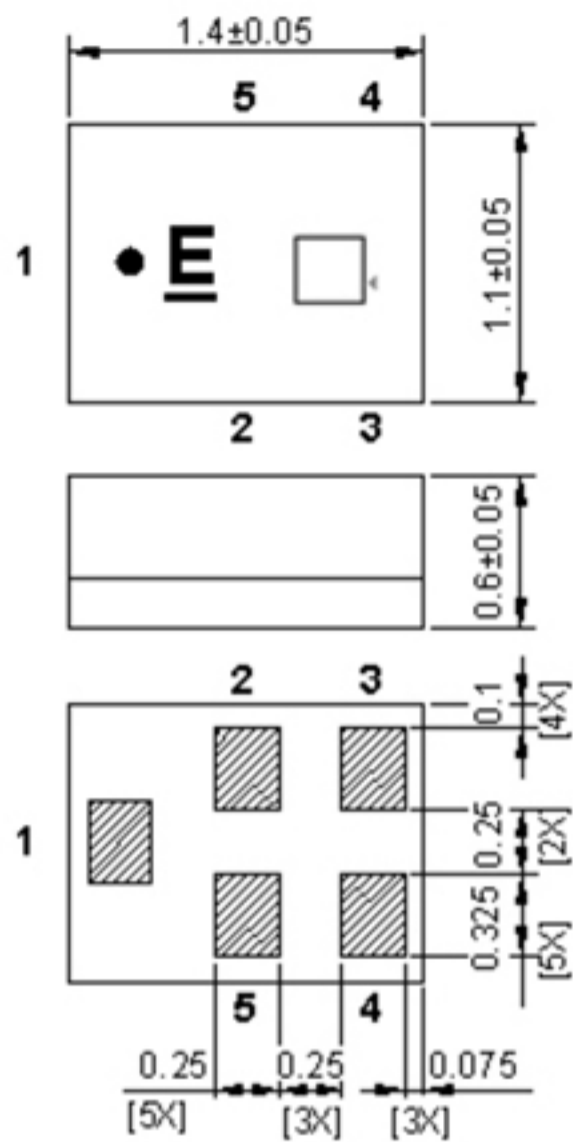

All tolerances are ± 0.05 mm unless otherwise specified
 Coplanarity : 0.1 mm max.
 1 to 5 : Pin No.
 Unit : mm

Pin-No.	Symbol	Function
1	IN	Input
2	GND	Ground
3	GND	Ground
4	OUT	Output
5	GND	Ground

□ : Year/Month Code (Follow the table)

YEAR/Month	1	2	3	4	5	6	7	8	9	10	11	12
2013	A	B	C	D	E	F	G	H	J	K	L	M
2014	N	P	Q	R	S	T	U	V	W	X	Y	Z
2015	a	b	c	d	e	f	g	h	j	k	l	m
2016	n	p	q	r	s	t	u	v	w	x	y	z
2017	<u>A</u>	<u>B</u>	<u>C</u>	<u>D</u>	<u>E</u>	<u>F</u>	<u>G</u>	<u>H</u>	<u>J</u>	<u>K</u>	<u>L</u>	<u>M</u>
2018	<u>N</u>	<u>P</u>	<u>Q</u>	<u>R</u>	<u>S</u>	<u>T</u>	<u>U</u>	<u>V</u>	<u>W</u>	<u>X</u>	<u>Y</u>	<u>Z</u>
2019	<u>a</u>	<u>b</u>	<u>c</u>	<u>d</u>	<u>e</u>	<u>f</u>	<u>g</u>	<u>h</u>	<u>i</u>	<u>k</u>	<u>l</u>	<u>m</u>
2020	<u>n</u>	<u>p</u>	<u>q</u>	<u>r</u>	<u>s</u>	<u>t</u>	<u>u</u>	<u>v</u>	<u>w</u>	<u>x</u>	<u>y</u>	<u>z</u>

D. MEASUREMENT CIRCUIT:

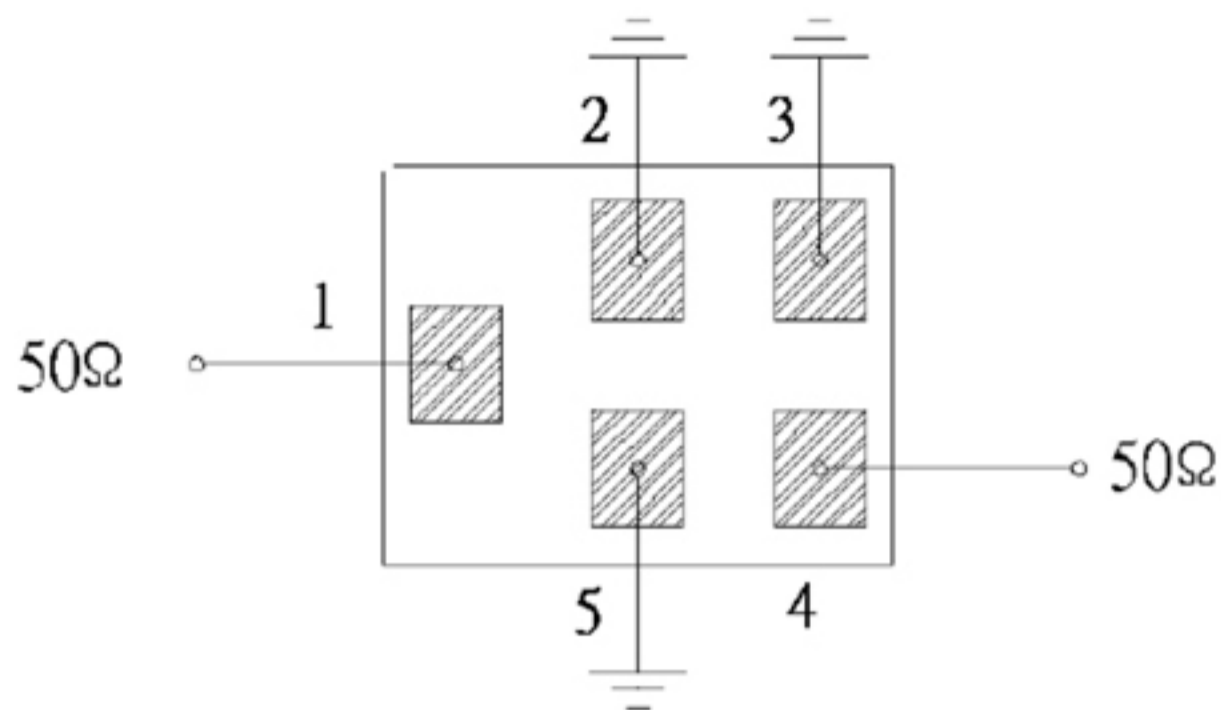

E. Frequency Characteristics: S21 response: (span 500MHz)

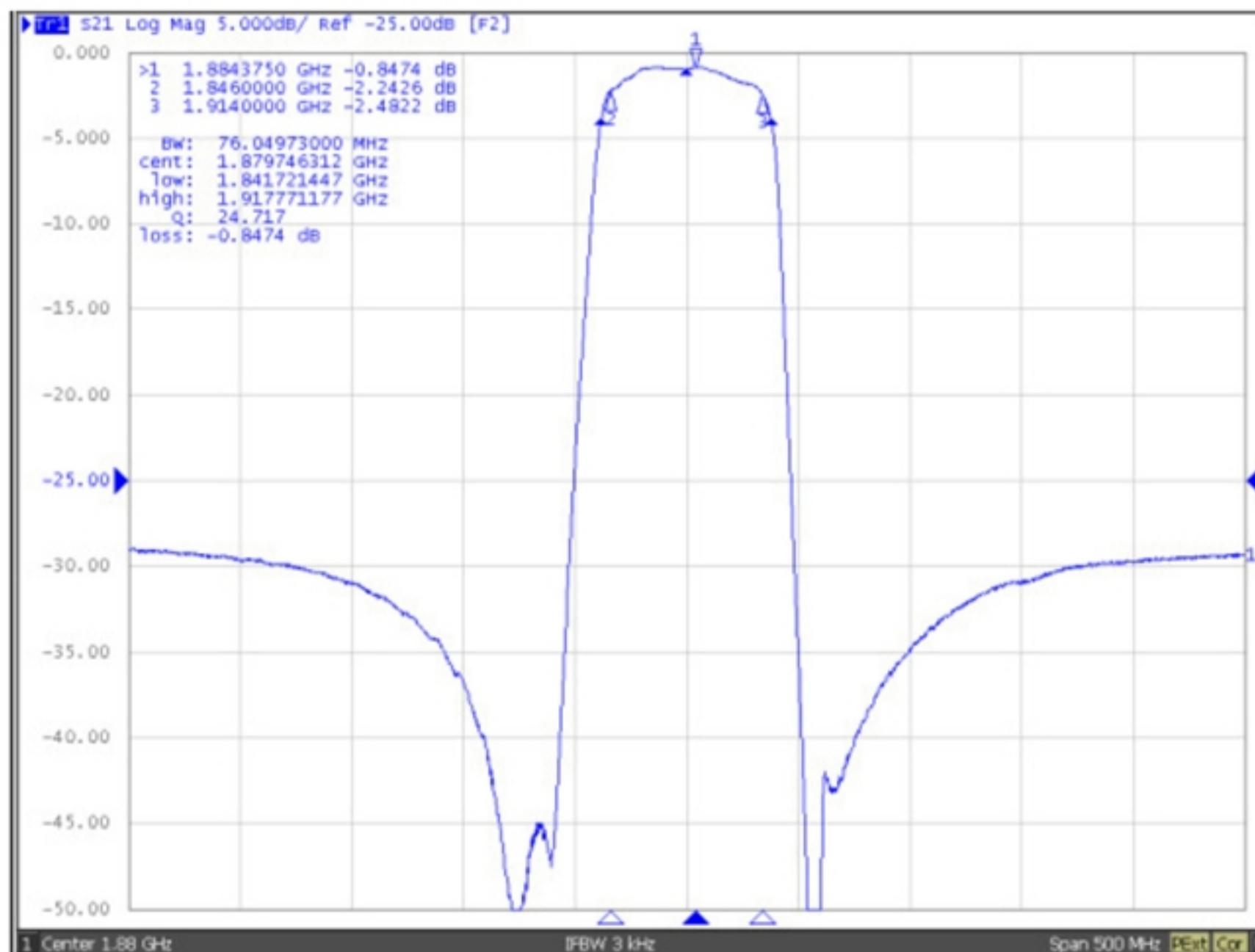

S21 response: (span 200MHz)

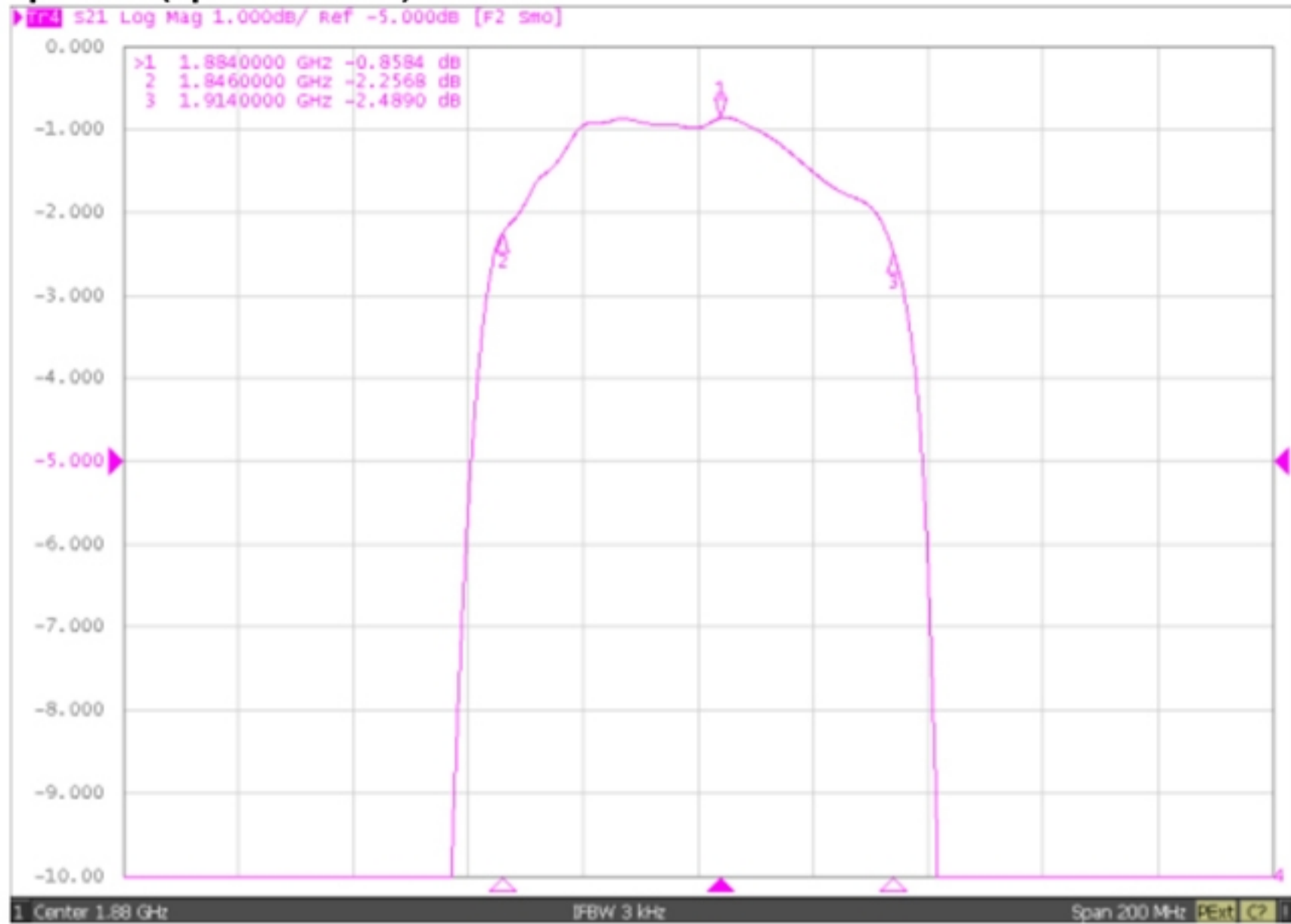

S21 response: (span 3000MHz)

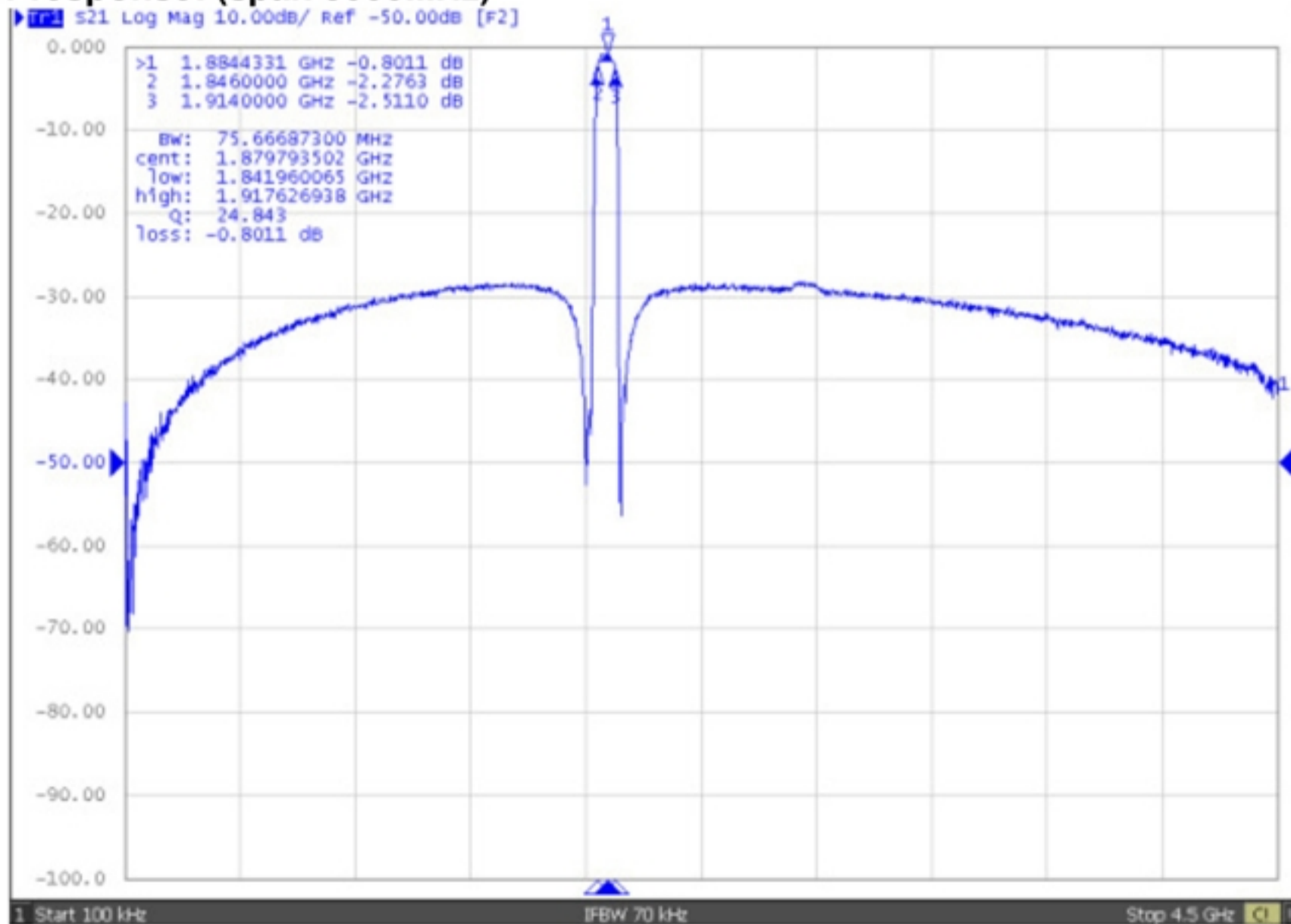

S11/S22 response:

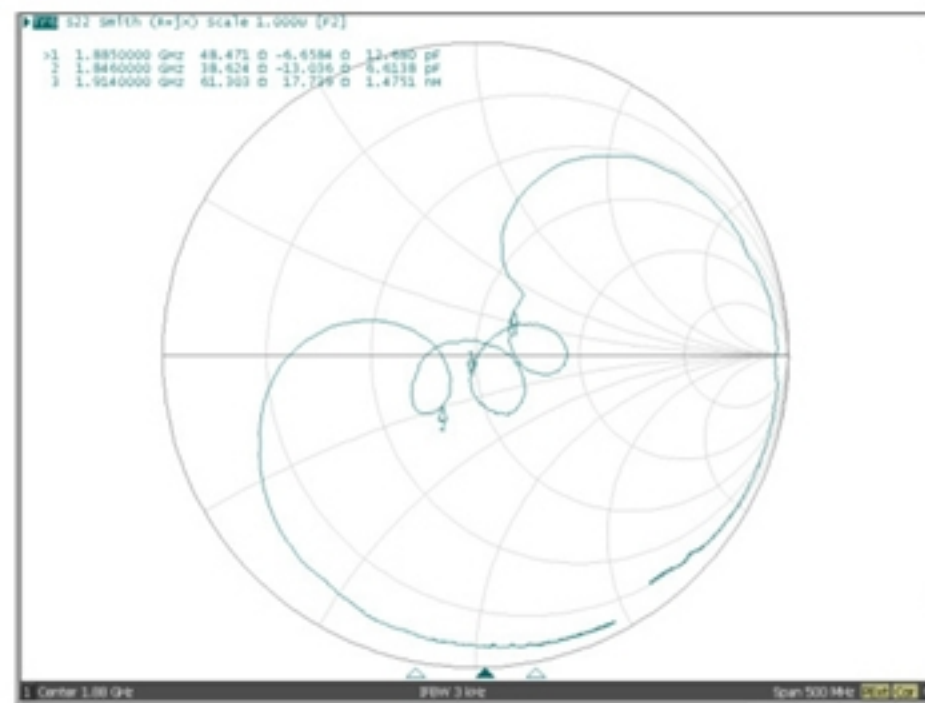
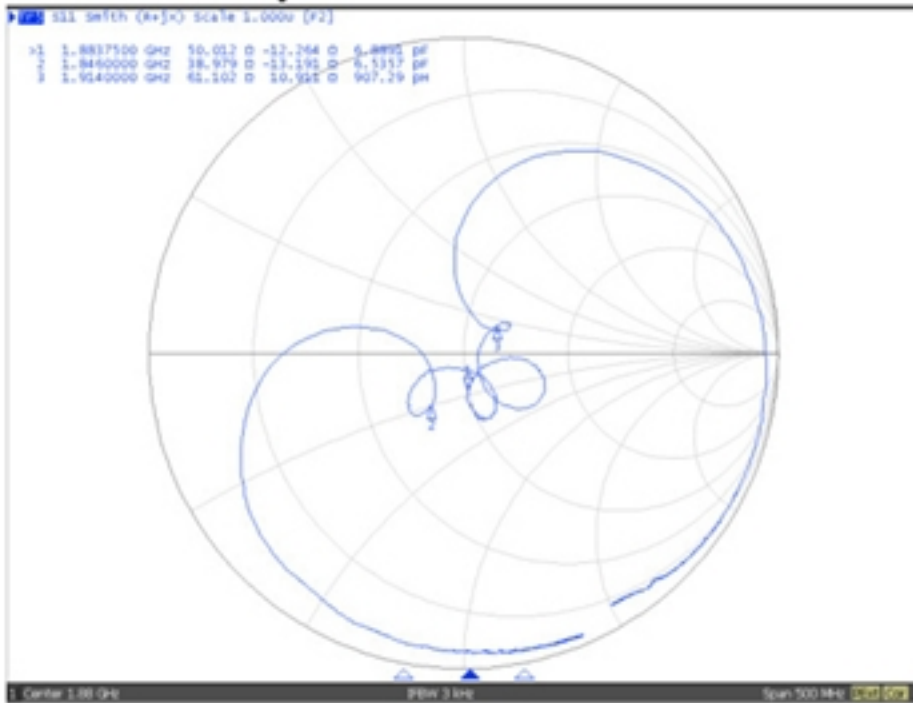

F. PCB Footprint:

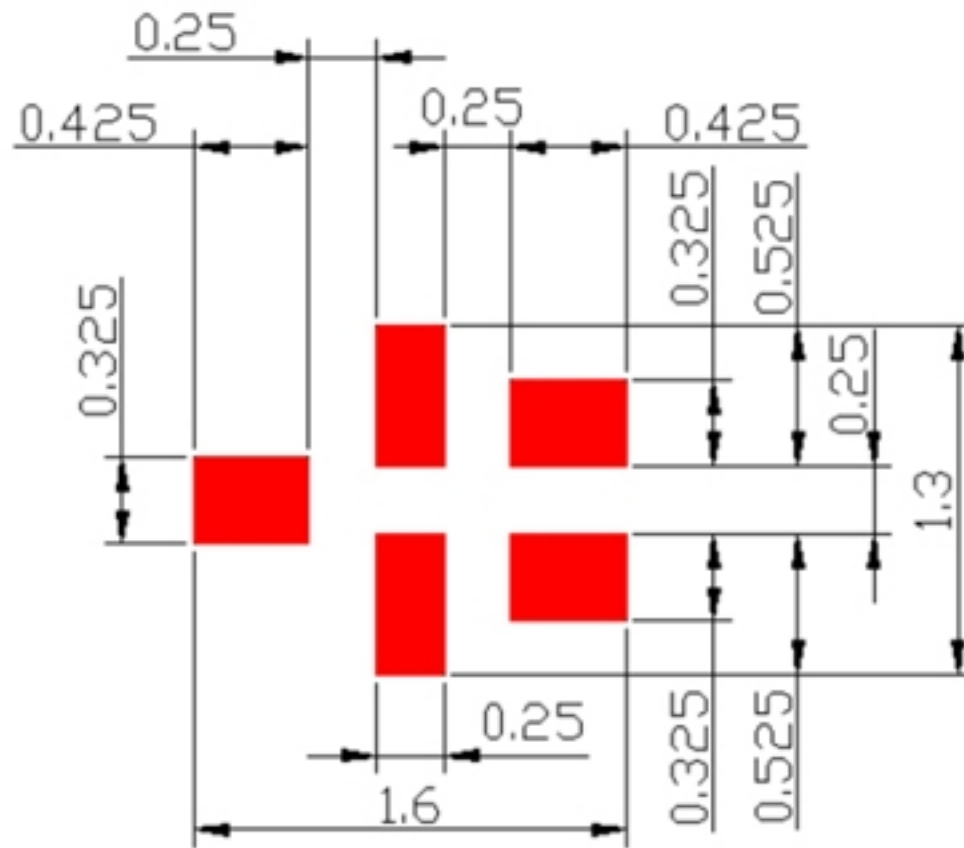

■ : Land Pattern

G. PACKING:

1. REEL DIMENSION

(Please refer to FR-75D10 for packing quantity)

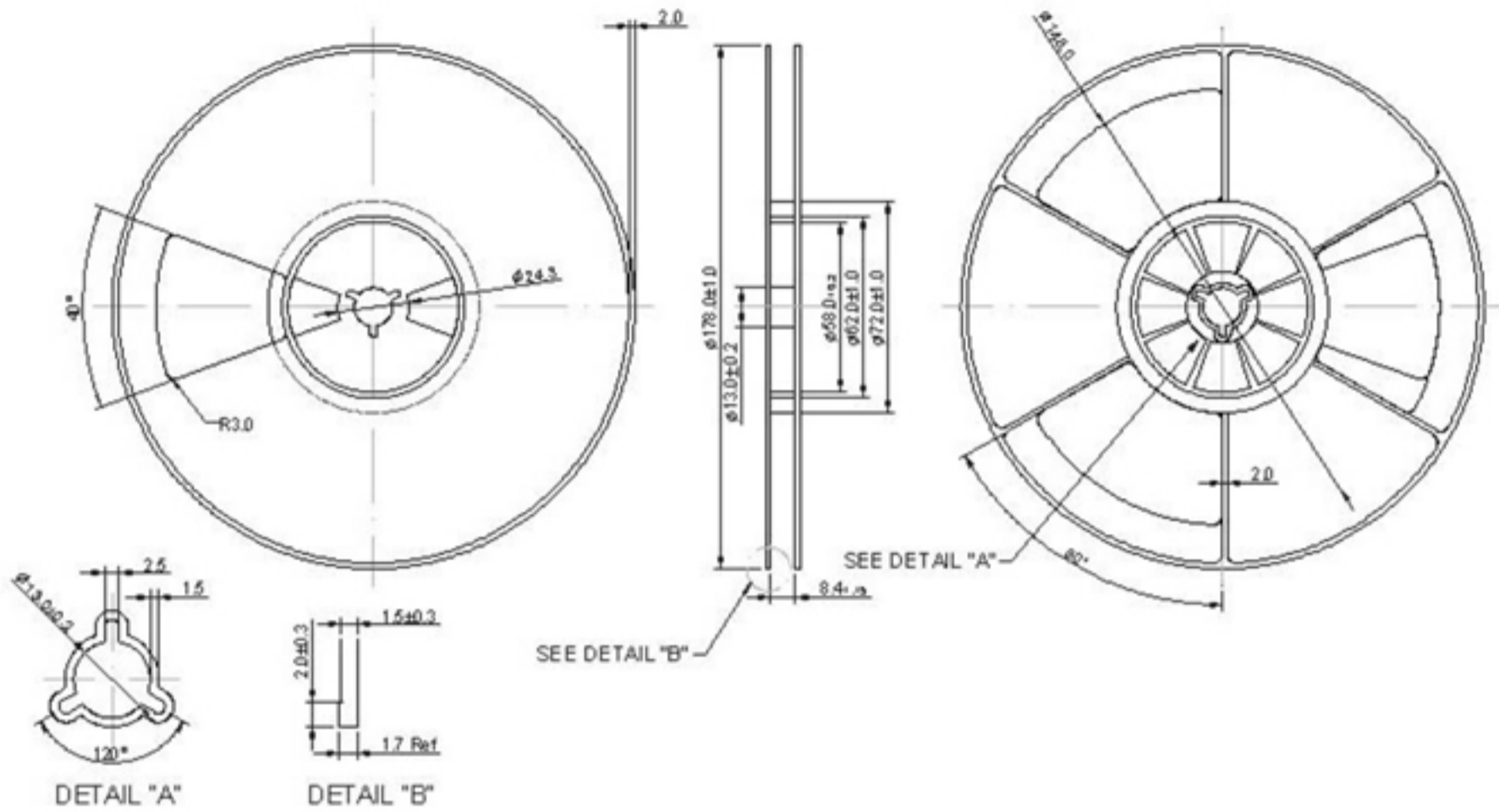

2. TAPE DIMENSION

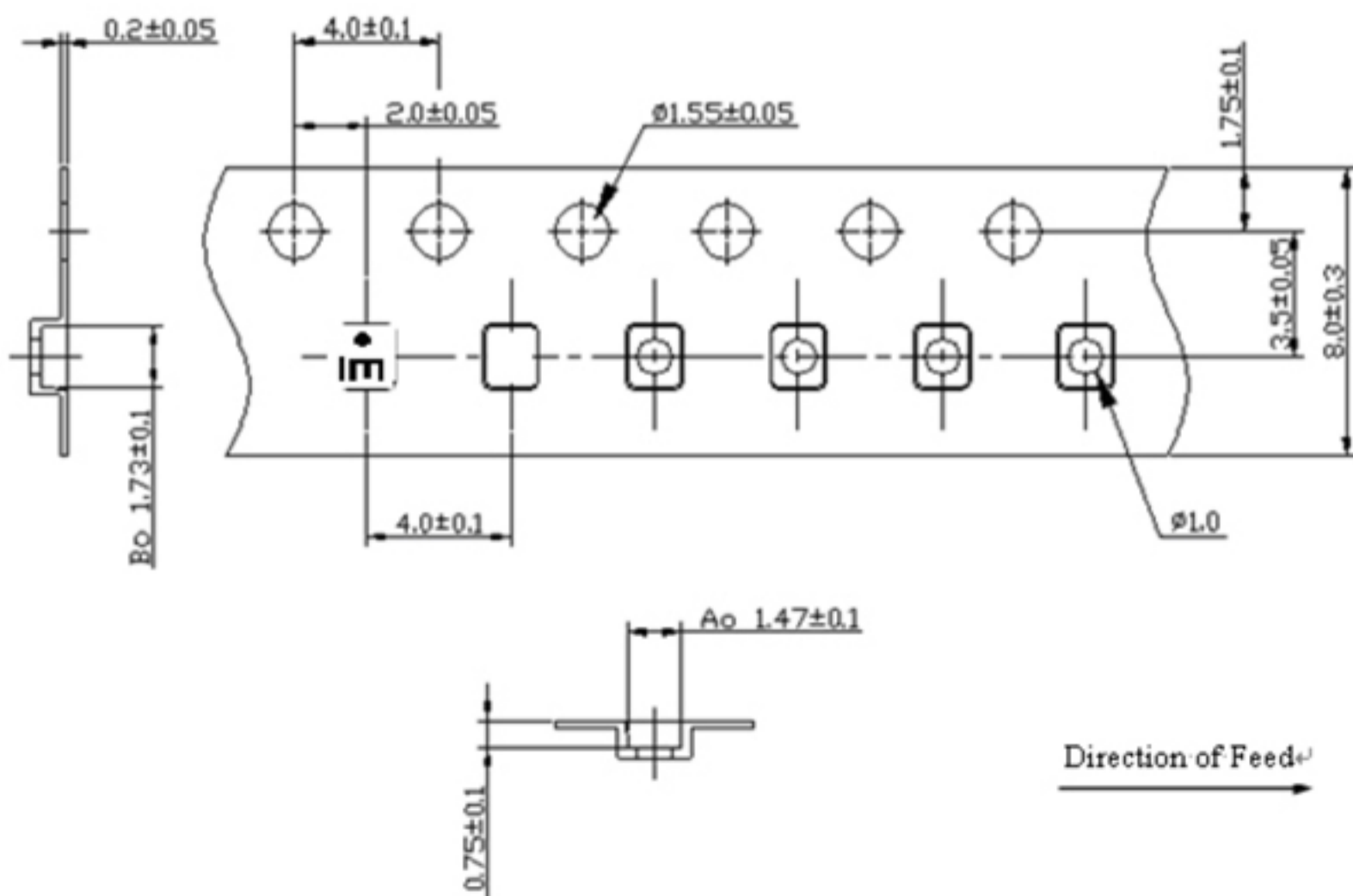

H. Recommended Reflow Profile:

1. Preheating shall be fixed at 150~180°C for 60~90 seconds.
2. Ascending time to preheating temperature 150°C shall be 30 seconds min.
3. Heating shall be fixed at 220°C for 50~80 seconds and at 260°C +0/-5°C peak (20~40sec).
4. Time: 2 times.

